



The Mercedes-Benz

EQC



Electric
Intelligence





Electric Intelligence by Mercedes-Benz. Collectively shaping the future with the EQ.

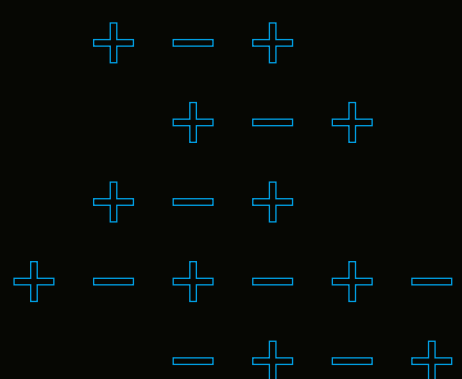
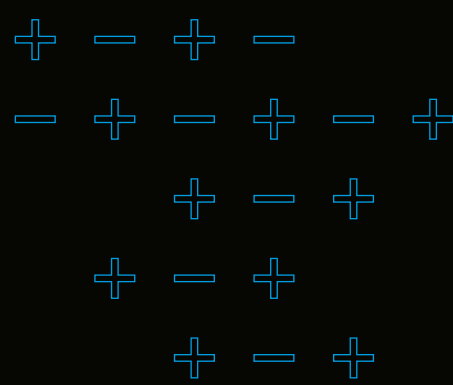

- + A century of Mercedes-Benz engineering expertise has culminated into “Electric Intelligence” with EQ
- + EQ is not only a brand, but also an attitude towards the future
- + It represents intelligent electromobility and the two Mercedes-Benz brand values - “emotion and intelligence”

**Please read the disclaimer.*



Mercedes-Benz sustainability with the EQ.

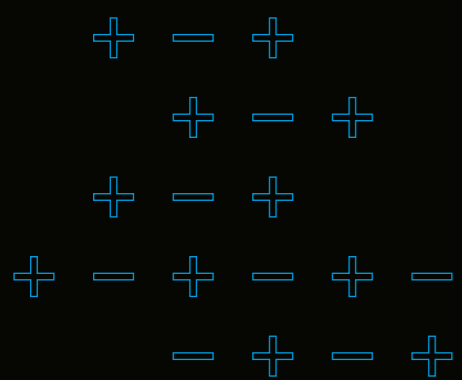
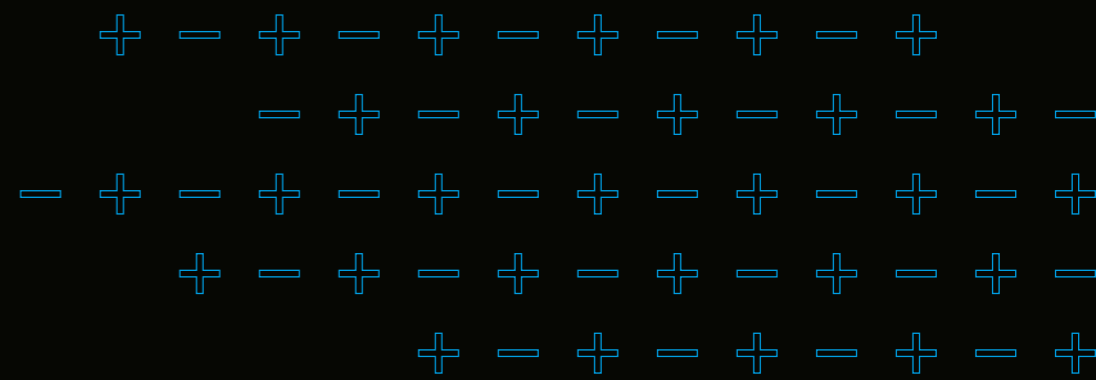

- + More than an electric drivetrain
- + Creation of 'sustainable luxury' with bold, groundbreaking and human-centric innovations
- + A more responsible brand to help better the environment
- + With the Laureus movement, we launched an initiative that aims to change the game for kids.

**Please read the disclaimer.*

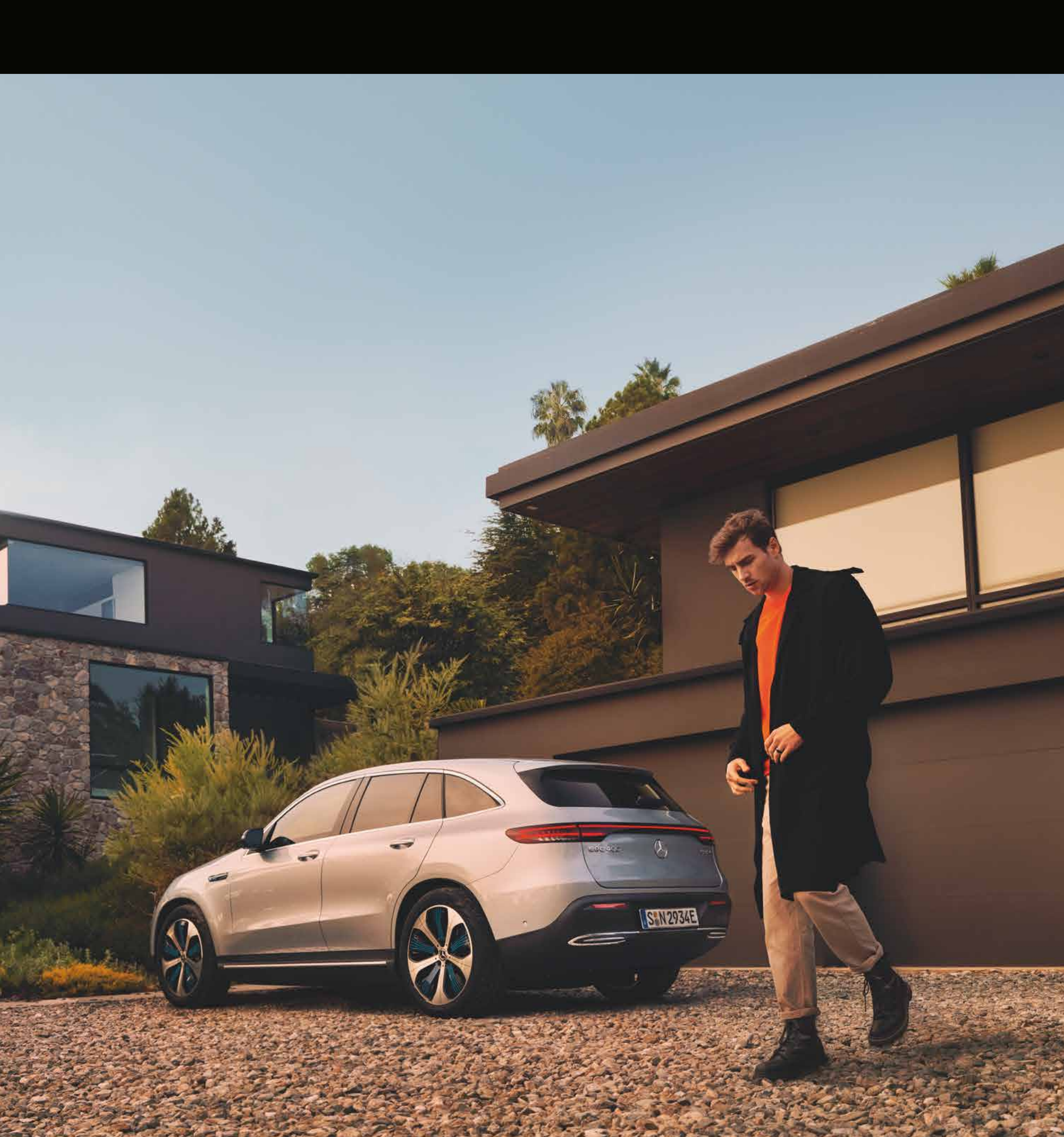

A true Mercedes.

Electric driving at its finest.

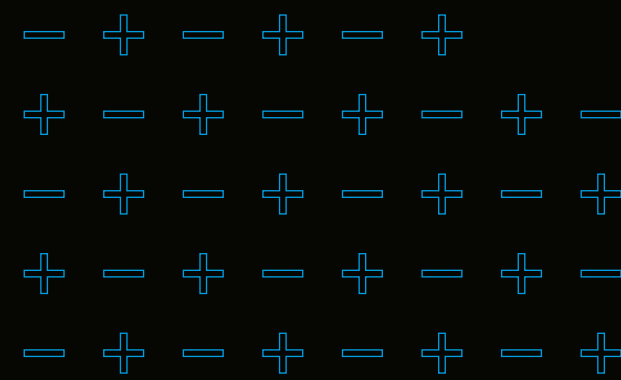

- + Pioneering mobility is written all over the face of the new EQC.
- + Exterior elements such as the headlamps and the radiator grille have a fascinating black-panel.
- + Progressive interiors such as the trim elements, upholstery and colours were developed exclusively for the EQC to define its uniqueness.

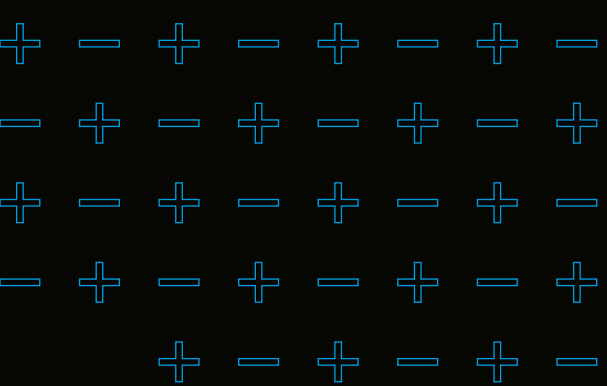



Even more alluring in the EQC: the Mercedes-Benz User Experience.

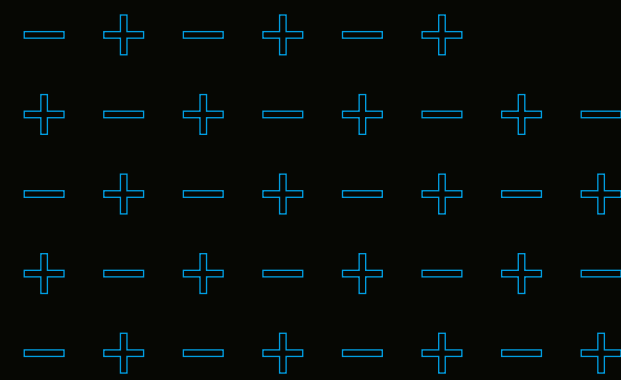

- + Using natural speech or intuitive touch control, the MBUX offers users maximum freedom for controlling all functions.
- + The media display in the new EQC is designed as a touchscreen, while the centre console includes an integral touchpad that responds to single and multiple-finger gestures as well as handwriting.

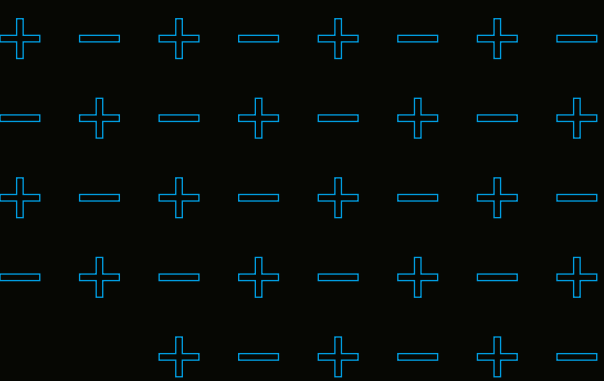

**Please read the disclaimer.*



Something special. On every trip, from any angle.
With the **Fit & Healthy** features.

The new EQC is a thoughtful companion through your journey with its Fit & Healthy features that understand, motivate and guide to keep you in the prime of your health while driving.

- + ENERGIZING Package
- + Ambient lighting with 64 colours
- + Cruise Control
- + THERMOTRONIC 3-Zone automatic climate control and integral fine particulate activated charcoal filter
- + Advanced sound system
- + Electrically adjustable seats with Memory function and Lumbar support.

**Please read the disclaimer.*



Charge with the Mercedes-Benz Wallbox.

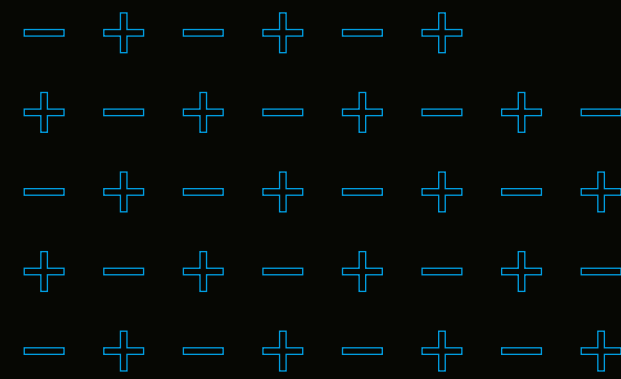

- + Fully charge the EQC while relaxing on the sofa – the Mercedes-Benz Wallbox Home makes it possible.
- + With a charging capacity of 7.4 kW you can charge the EQC up to three times quicker than at a conventional household socket.
- + It would be installed at your preferred location at home.
- + When on road, you could also charge the EQC at the dealerships.

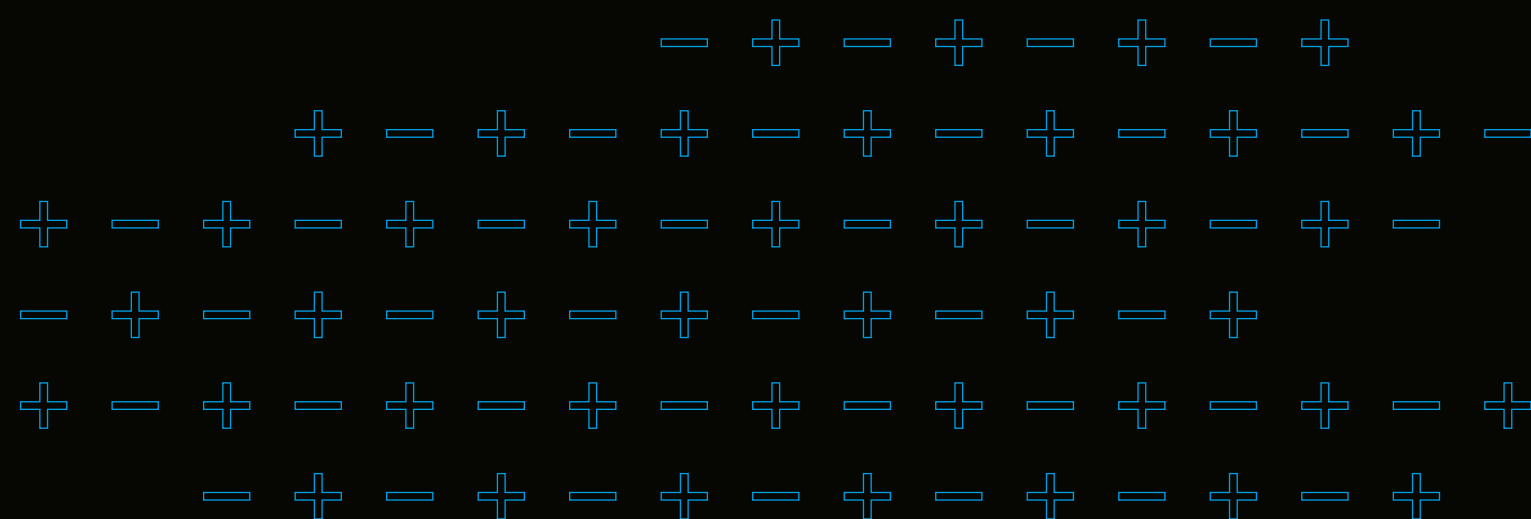
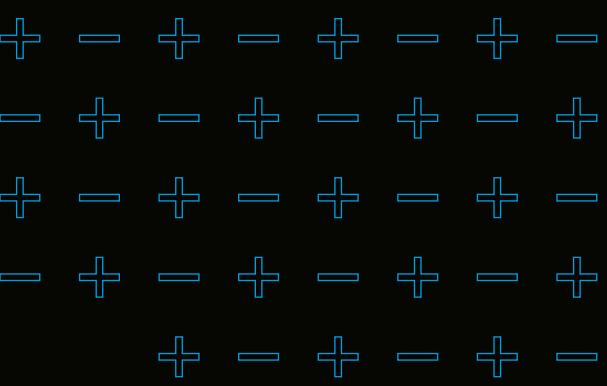

**Please read the disclaimer.*

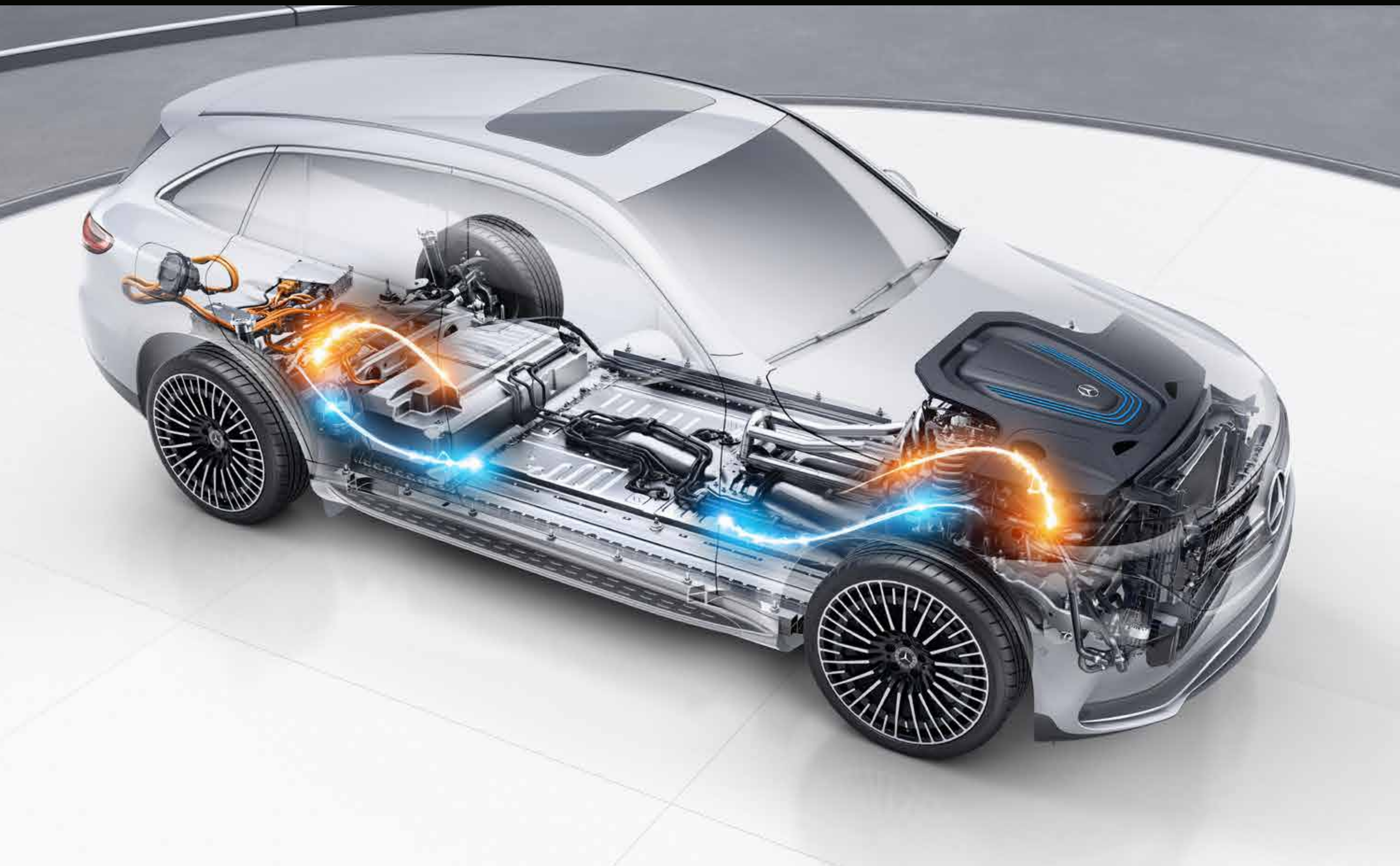

Electric Drivetrain

- + An electric motor on each of the axles converts electrical energy into mechanical energy for impressive forward thrust.
- + The intelligent operating strategy of the drive components, the system output of 300 kW (408 hp) is always available when needed – for efficient and practically silent operation.
- + The electric drivetrains have different configurations to reduce electrical consumption and boost dynamism: the front electric motor is optimised to provide maximum efficiency in low to medium load ranges, while its rear counterpart determines the dynamism.

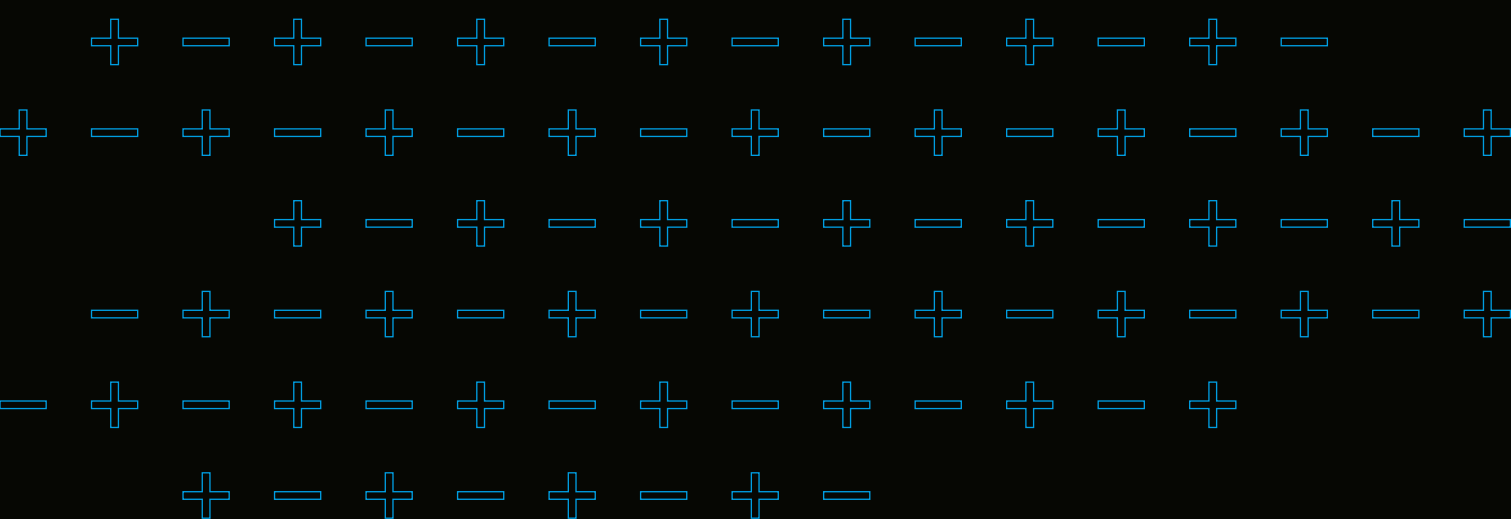
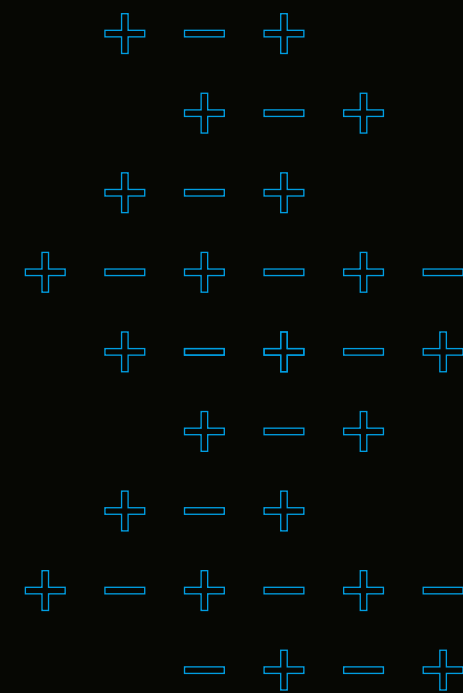

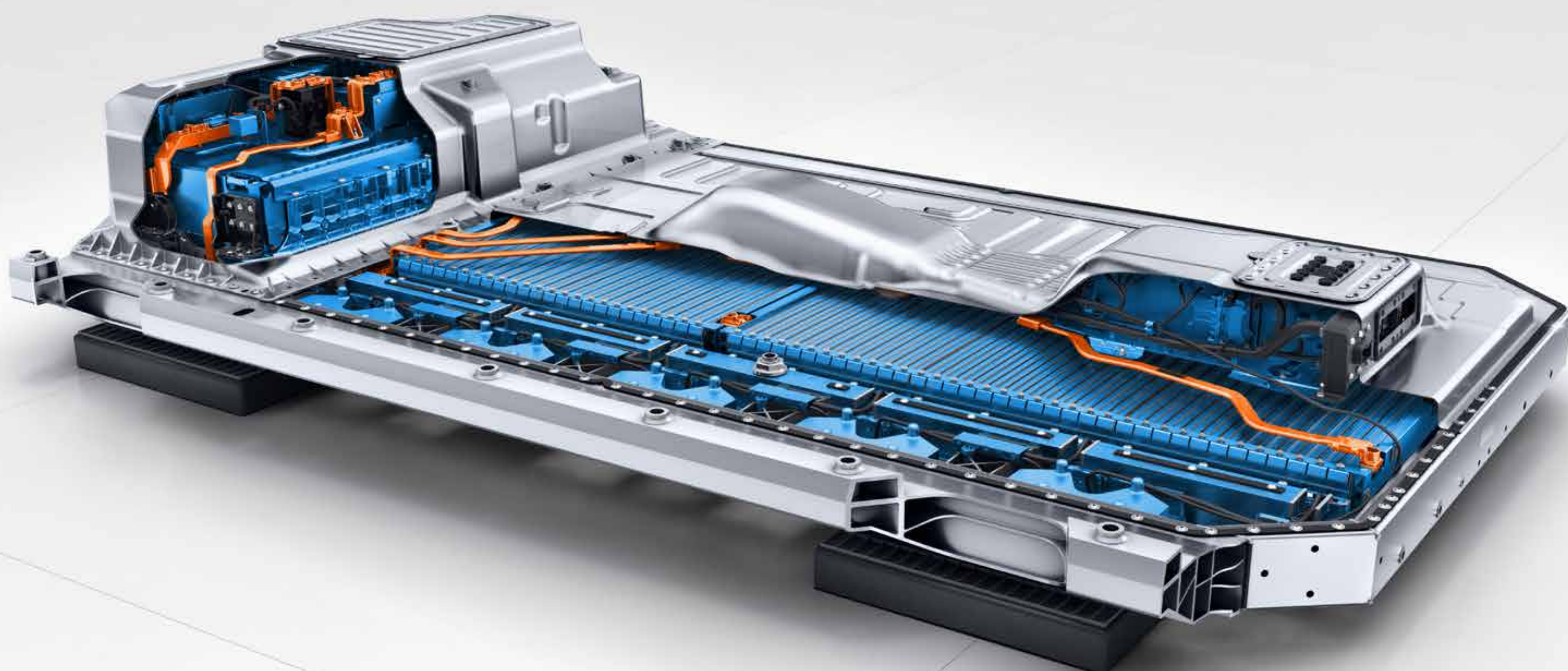

Battery technology

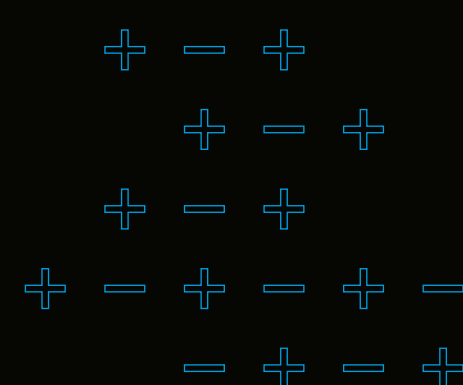

The EQC's high-voltage lithium-ion battery is the central energy store for the electric drive. Both the range and the performance of the electric drive are directly dependent on the capabilities of the battery.

- + High power-to-size ratio with a nominal capacity of approx. 210 Ah and a usable energy content of approx. 76.4 kWh
- + Modular system design with two modules of 48 cells and four modules of 72 cells for a compact design
- + High maximum voltage of approx. 408 V

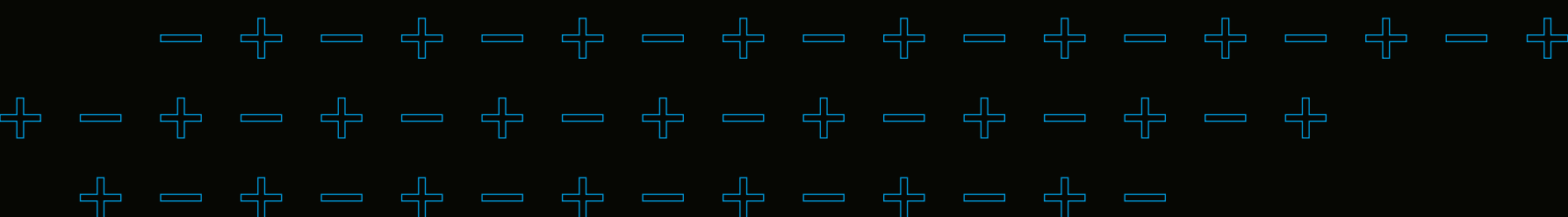

**Please read the disclaimer.*

The Li-ion battery disposal cost at actuals may be charged as per the law and regulations in force at the time of disposal of battery.

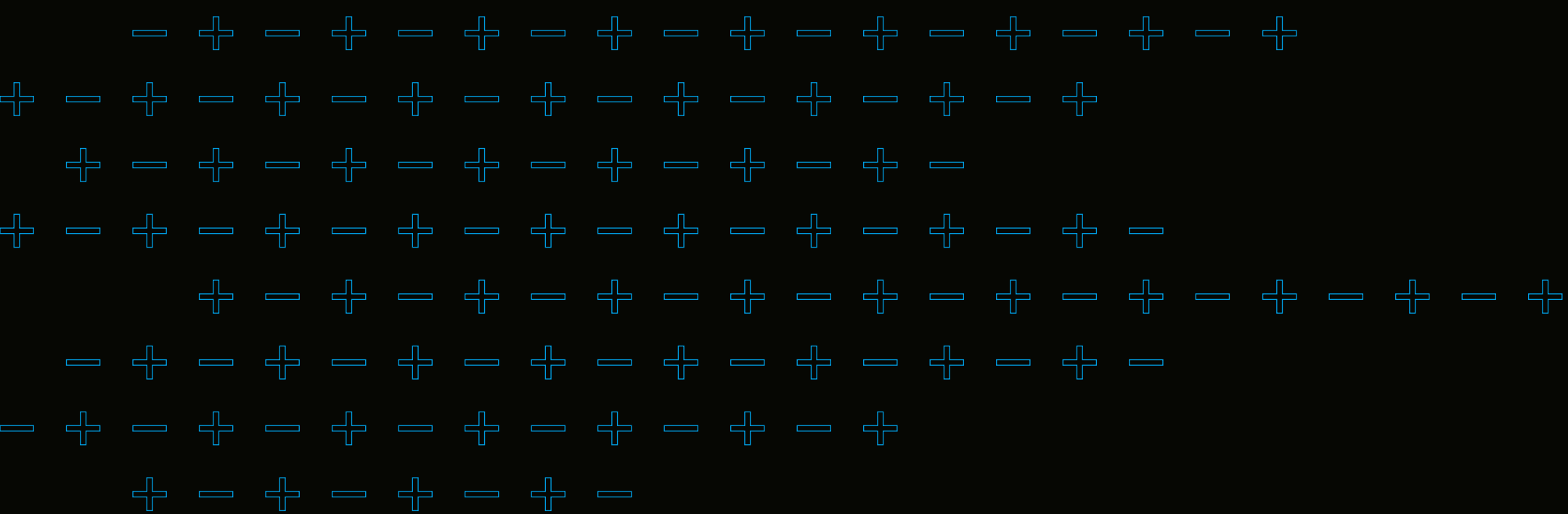

- + Optimum operating temperature of the batteries is ensured by liquid cooling – at low temperatures battery heating (PTC) ensures that the best performance and efficient range is maintained
- + Cooling circuit takes care of both cooling of the batteries as well as the interior
- + Installation in the underbody for a dynamically favourable, low overall vehicle centre of gravity
- + Protection against possible damage thanks to mounting management with housing covers and also incorporation into the crash concept

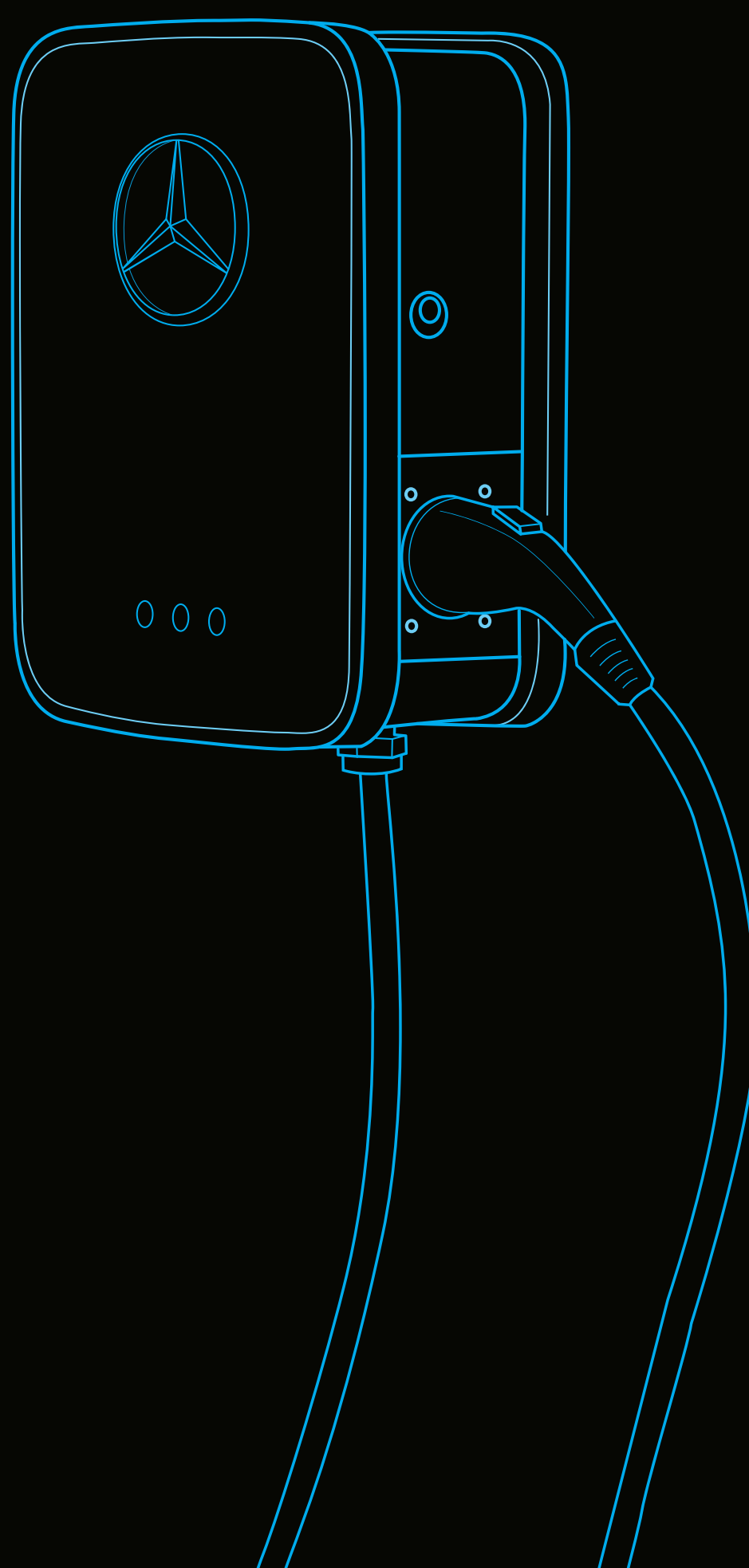
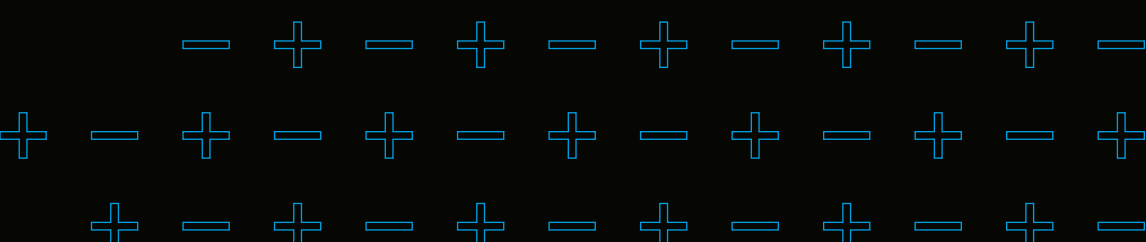
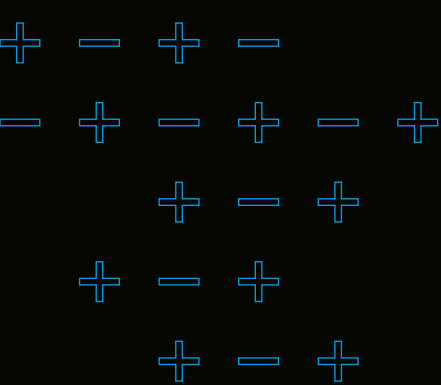

**Please read the disclaimer.*

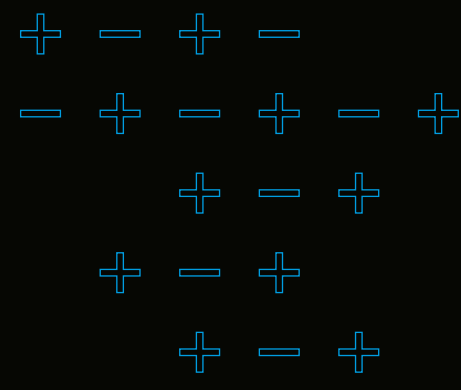

MULTIBEAM LED Headlamps

- + The standard MULTIBEAM LED headlamps with its inner housing in high-gloss black, blue trim lines has a distinctive light design.
- + At night it really catches the eye and draws attention.

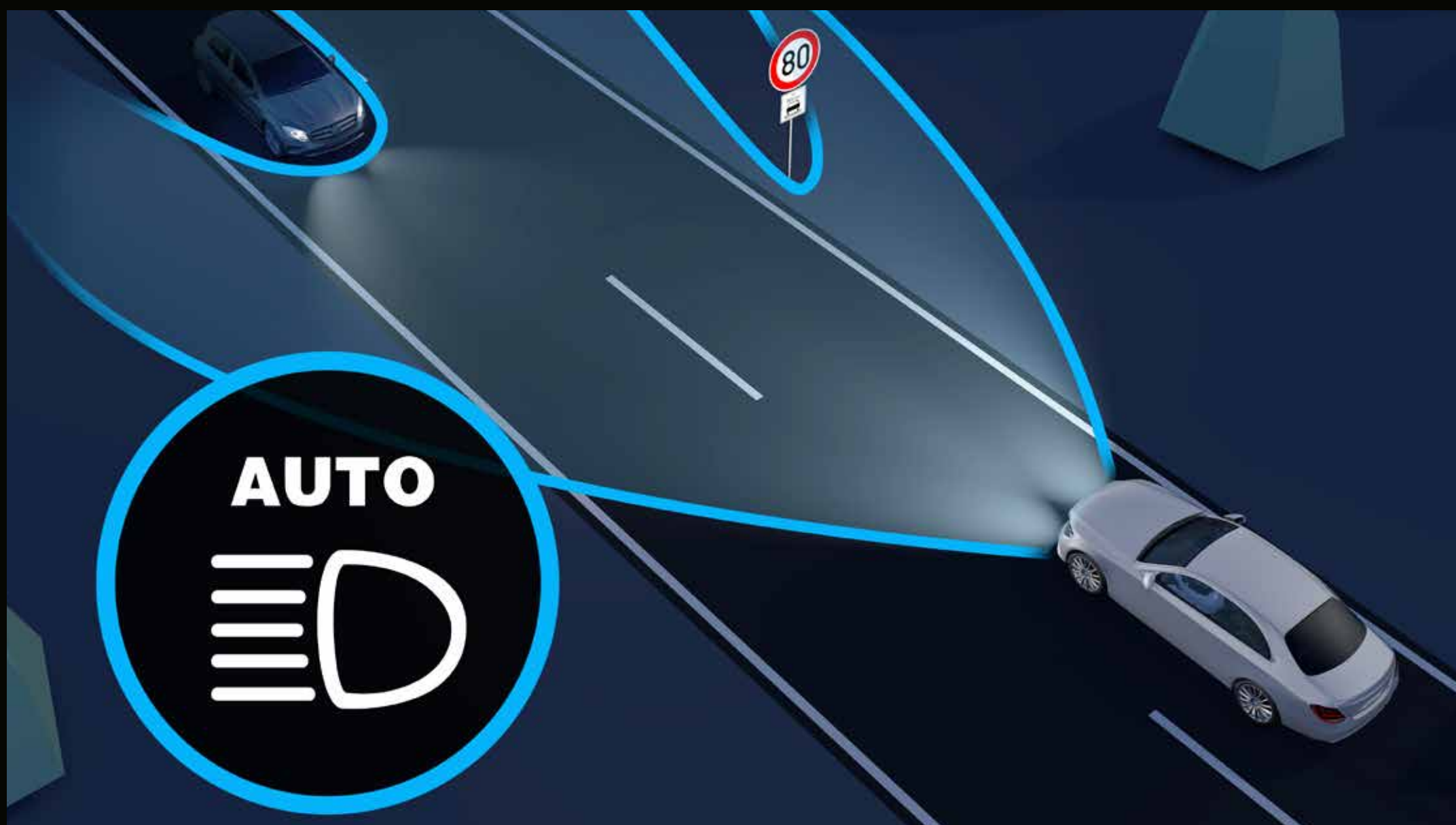

Adaptive Highbeam Assist Plus

- + Adaptive Highbeam Assist Plus motto - see very far, don't dazzle
- + Permanent main beam - virtually turns night into day and relieves the strain.
- + It spares oncoming traffic or vehicles in front with highly precise LEDs: you do not have to keep on changing over to low-beam headlamps.

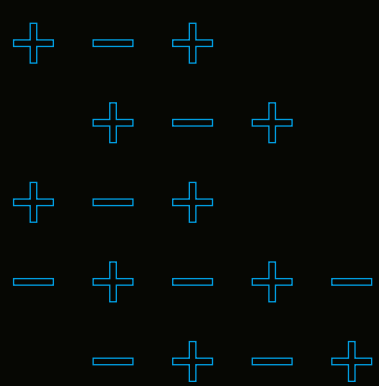



Mirror package

- + Electrically folding exterior mirrors with an operating button in the control panel of the driver's door
- + Automatic lowering of the front passenger mirror glass to the parking position when reverse gear is selected
- + Automatically dimming exterior mirror on the driver's side and the rear-view mirror
- + Ambient lighting of the exterior mirror to illuminate the access area

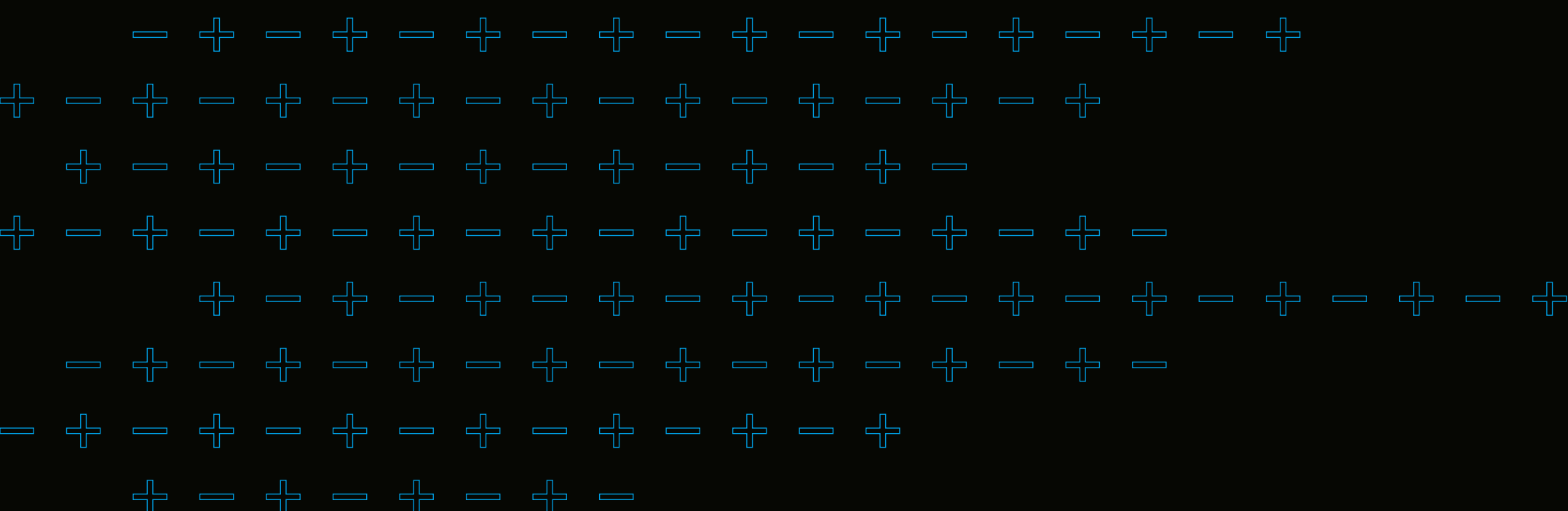
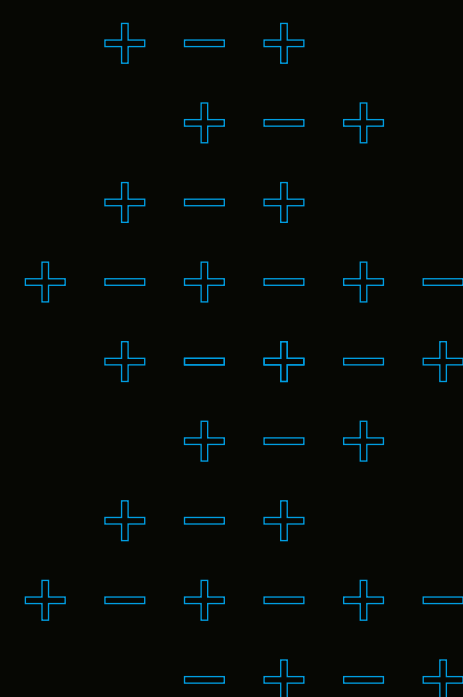

**Please read the disclaimer.*



Electric Sliding Glass Sunroof

- + It allows more light and air into your vehicle
- + Lends a brighter ambience to the interior
- + A movable roof liner gives additional protection from the sun

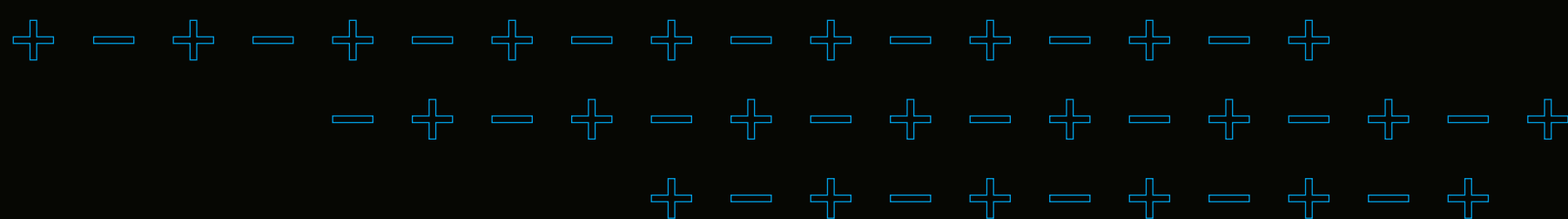

Aluminium-look Running Boards With Rubber Studs

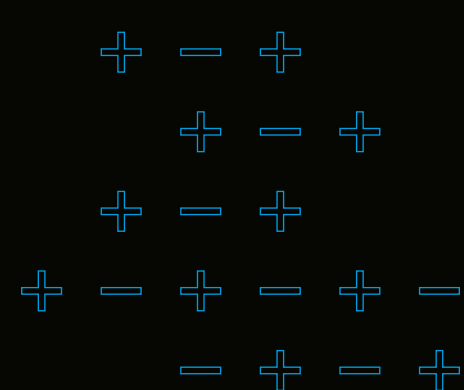

- + Ease and convenience - The aerodynamically optimised anti-slip rubber studs mounted on the side at the height of the side skirts.



Standard Exterior Highlights

- + Black-panel radiator grille with louvres and surround in chrome
- + MULTIBEAM LED and LED light bands at the front and rear
- + Front apron and side sill panels in black
- + 50.8 cm (20-inch) 10-spoke light-alloy wheels, painted in high-gloss black with energy blue decorative elements and a highsheen finish
- + Badge on the wing in high-gloss black with chrome stripes and blue “EQC” lettering

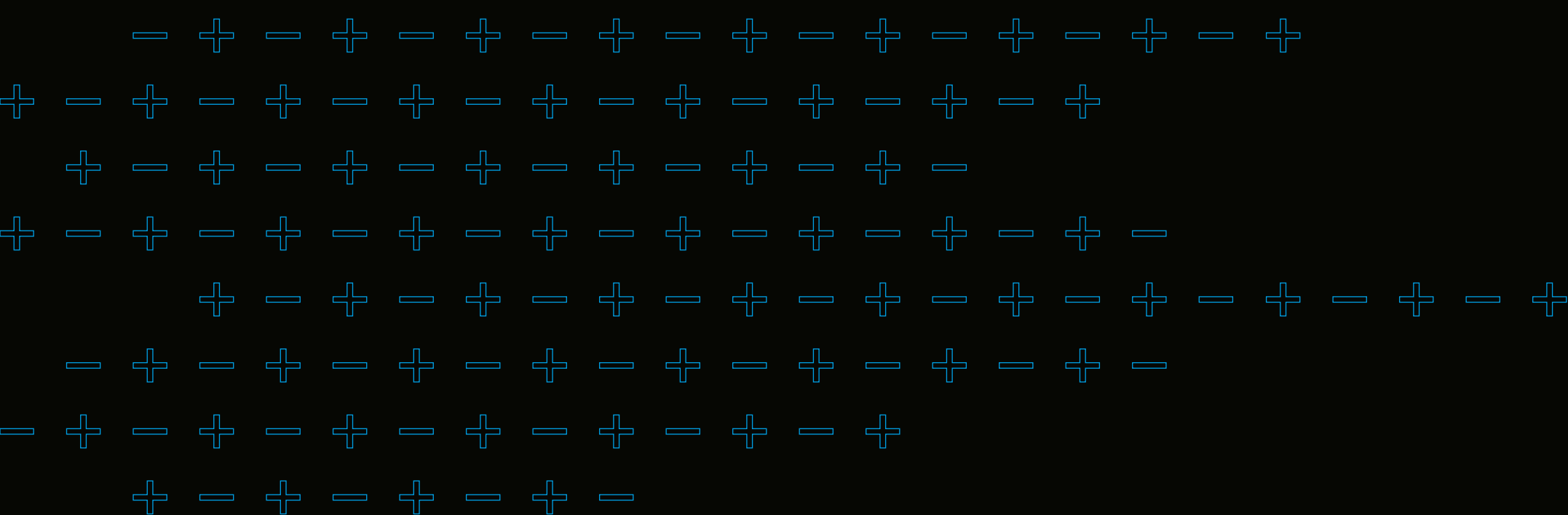
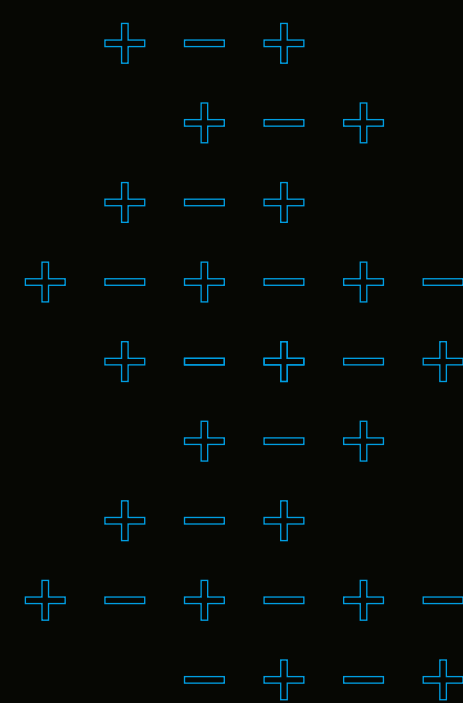

**Please read the disclaimer.*



Standard Interior Highlights

- + Front seats upholstered in black Aberdeen fabric with graphite topstitching
- + Multifunction sports steering wheel in leather with spokes and controls in high-gloss black
- + Dashboard with fine surface structure in metallic silver grey. Beltline with finely structured surface
- + Widescreen Cockpit with fully digital instrument display, media display and touchpad
- + MBUX multimedia system with hard-disc navigation, extended MBUX functions and MBUX Interior Assistant

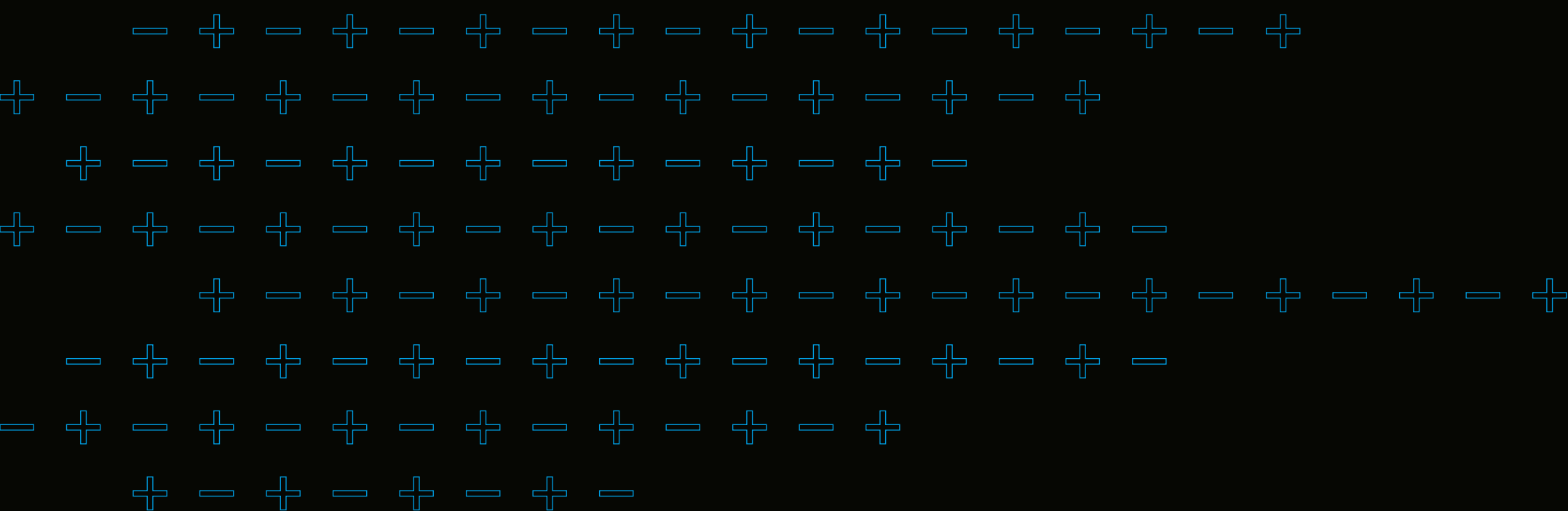
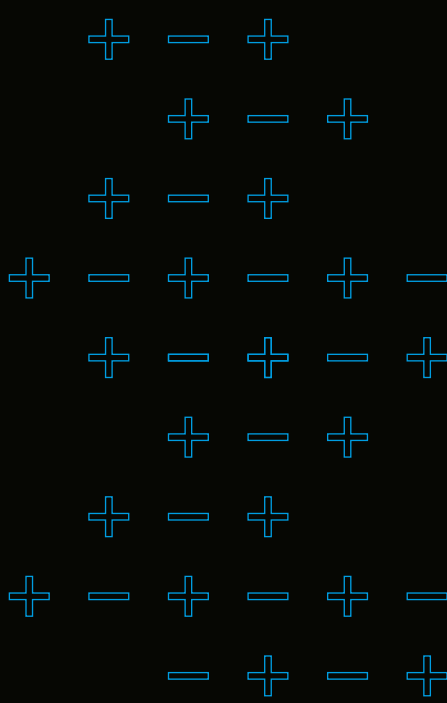

Hey Mercedes

MBUX features in the EQC

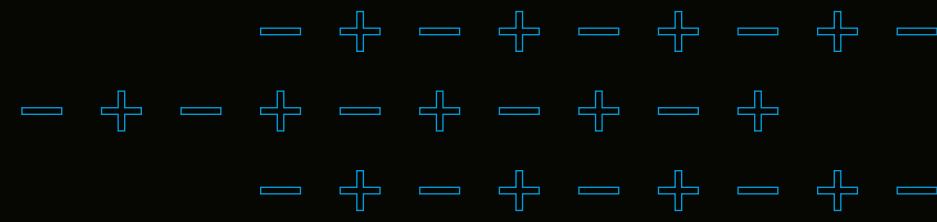

Voice Control

- + “Hey Mercedes.” This is how you launch the natural voice control.
- + It responds to almost every word and can even process indirect speech.
- + In the EQC, you can also use the voice control to programme charging. You could say “charge to 85 percent” or even ask about the range.

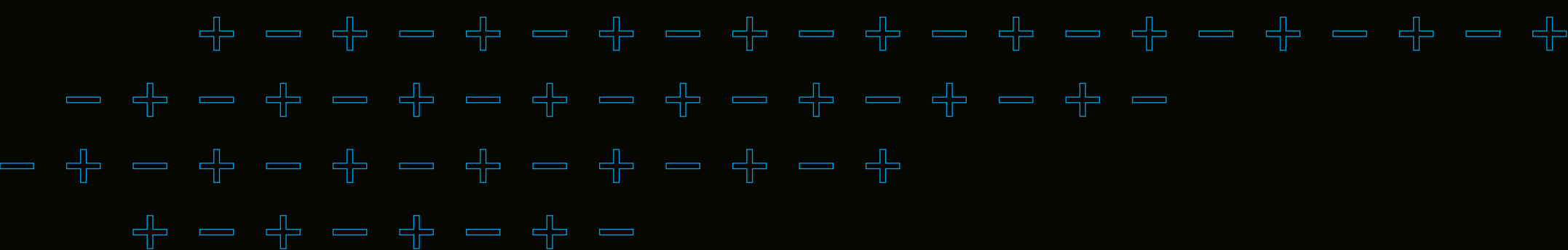

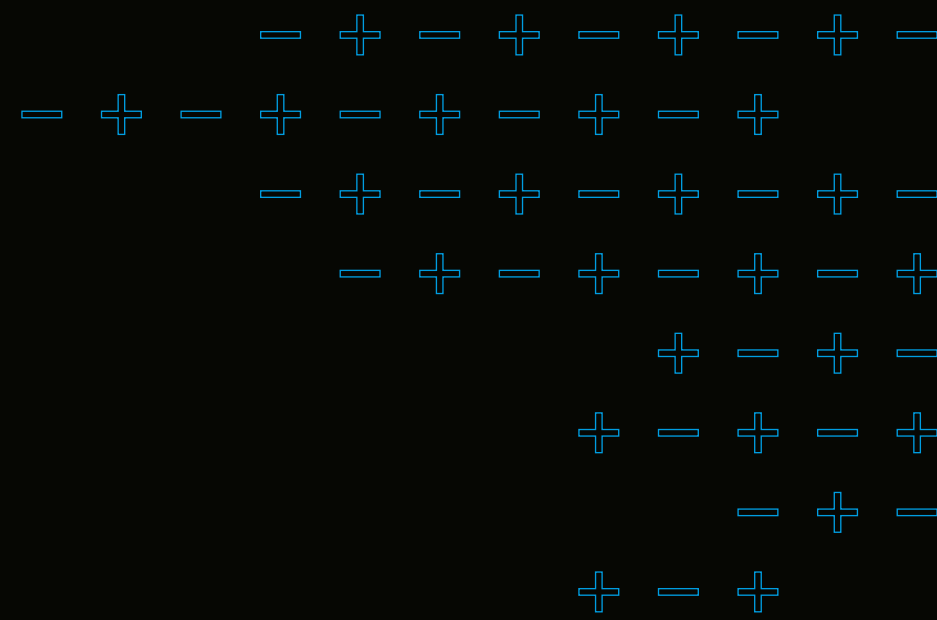

Touch Control Concept

- + MBUX offers you maximum freedom to control numerous functions in the way that is most comfortable for you.
- + The multimedia touchscreen display and integral touchpad in the centre console responds to single and multi-finger gestures.
- + Use of touch control buttons on the steering wheel so you don't have to take your hands off the wheel.

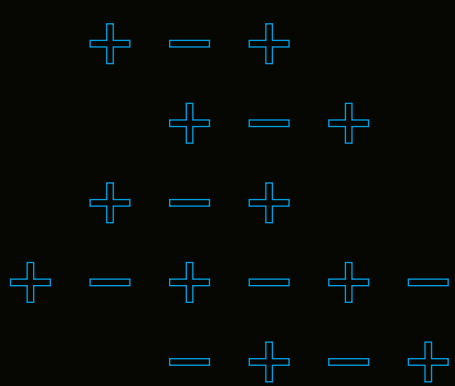

Display Styles

- + You can arrange and design the displays in the instrument cluster according to your own personal tastes.
- + There are three display styles available for visual appearance: modern classic, sport and electric art with informative colour changes.



ENERGIZING Package

The ENERGIZING package is a new feature – it offers you comfort for all the senses. Your Mercedes can vitalise you in a targeted manner for prolonged alertness at the wheel and a very pleasant drive.

+ ENERGIZING comfort programmes

- Refresh
- Vitality
- Training
- 3-minute audio information tips to relax your muscles.

+ ENERGIZING COACH

- Front seat heating
- AIR-BALANCE package for fragrancing, ionisation and filtering of the interior air
- Ambient lighting with programme-specific lighting moods

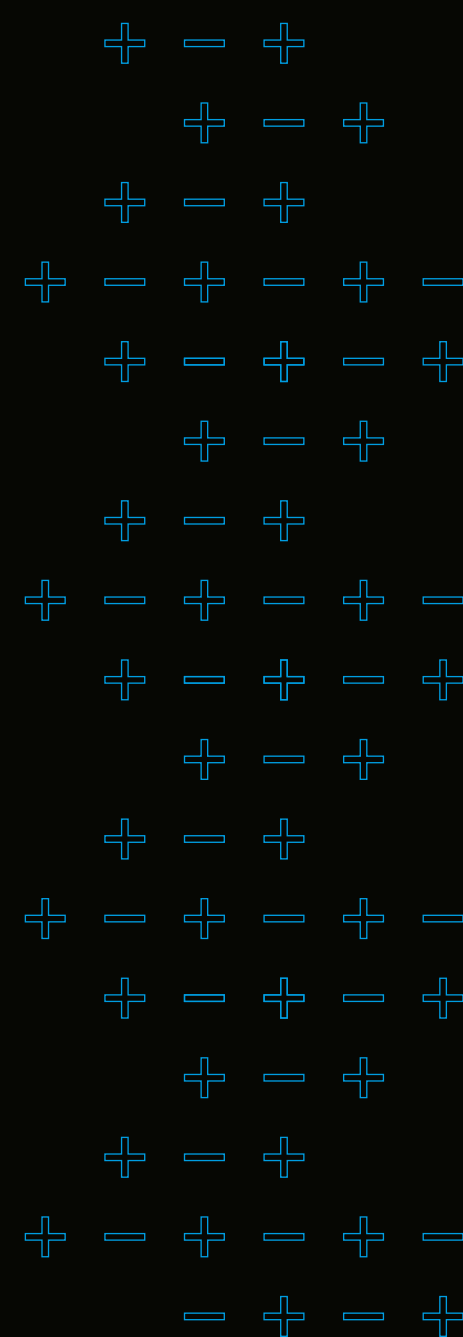



Electric Art interior

Redefine the ambience with innovative design concept.

- + Dashboard with fine surface texture in metallic silver grey and topstitching in rosé gold
- + Other topstitching in rosé gold such as on the armrest in the centre console, the door panelling in the front or the defrost area between the dashboard and windscreen
- + Trim elements in an aluminum look
- + Multifunction sports steering wheel in leather with steering wheel spokes in chrome, control panels in high-gloss black with controls in chrome
- + Door pins in chrome

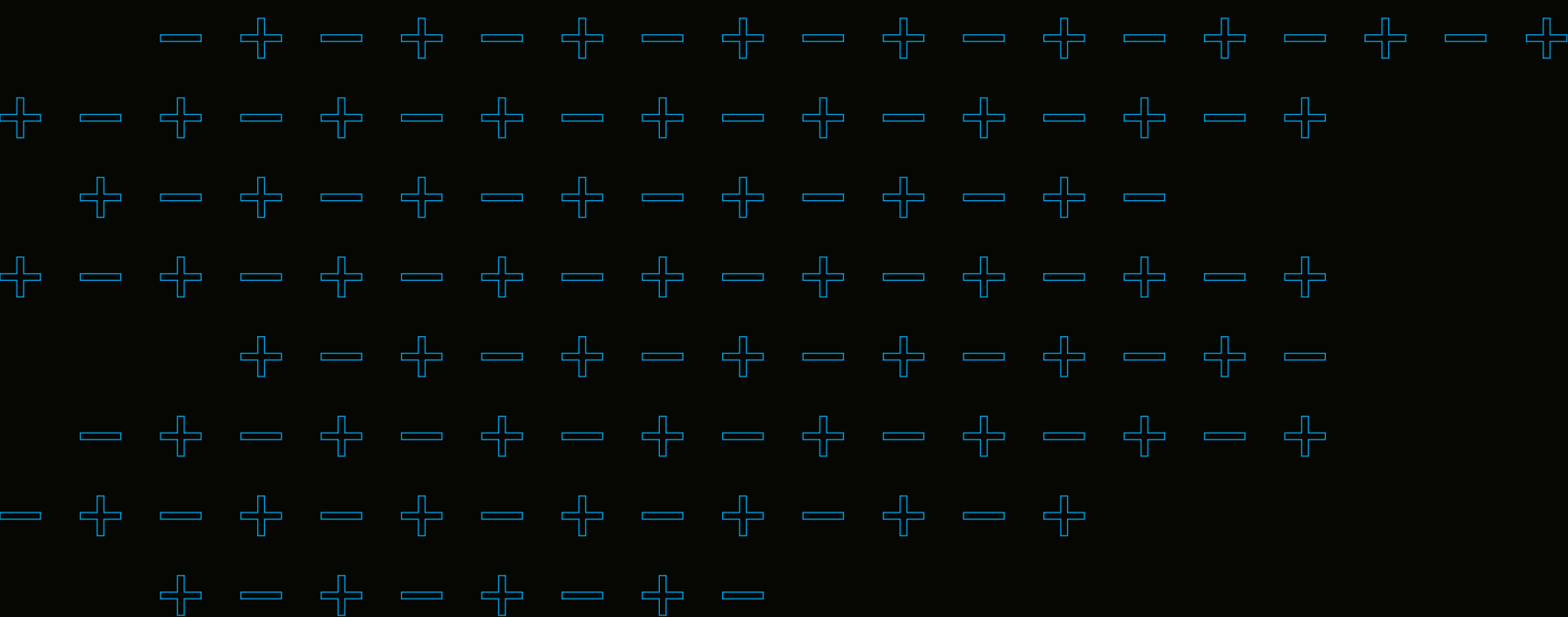
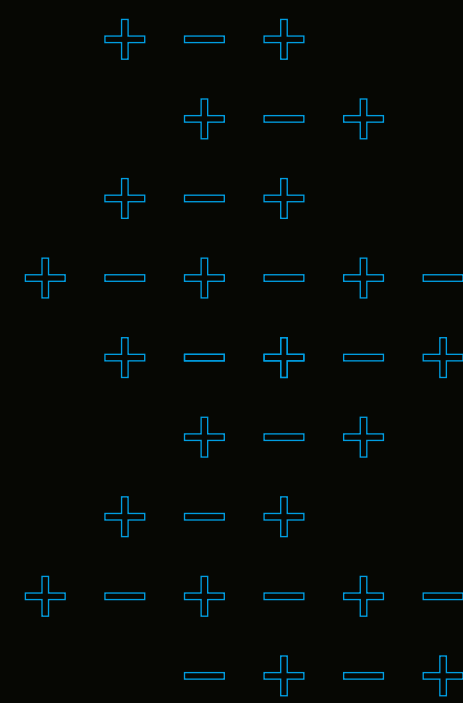

**Please read the disclaimer.*



Electric Art interior

Redefine the ambience with innovative design concept.

- + Upholstery in ARTICO man-made leather / Sunnyvale fabric in silk beige / black with topstitching in rosé gold
- + Upholstery in ARTICO man-made leather / Sunnyvale fabric in indigo blue / black with topstitching in rosé gold
- + Beltlines with fine surface texture, in black or blue depending on upholstery, with topstitching in rosé gold or mid grey

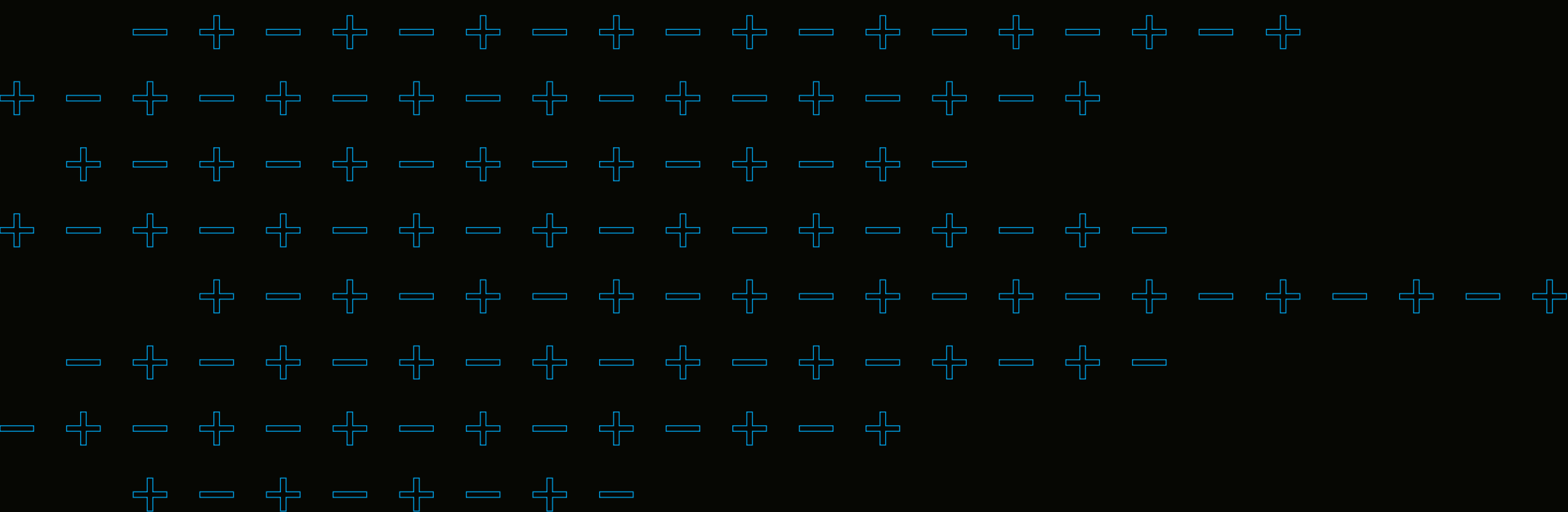
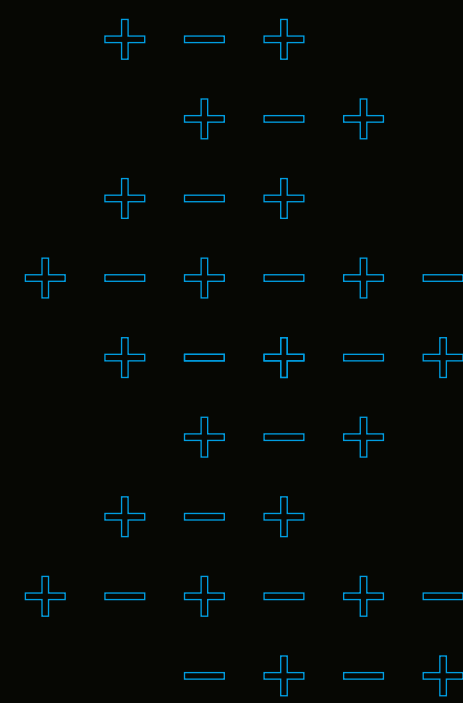

**Please read the disclaimer.*



Multicontour Seat Package

- + The Multicontour Seat Package adjusts the seat with more or less air in the seat side bolsters like a tailor-made suit.
- + Inflatable chambers in turn create a massage effect in the lumbar area.
- + Multicontour seats with inflatable air chambers in the lower backrest and in the side bolsters, this improves lateral support for sporty driving manoeuvres.
- + Electrically adjustable lumbar support provides additional support for the spine.

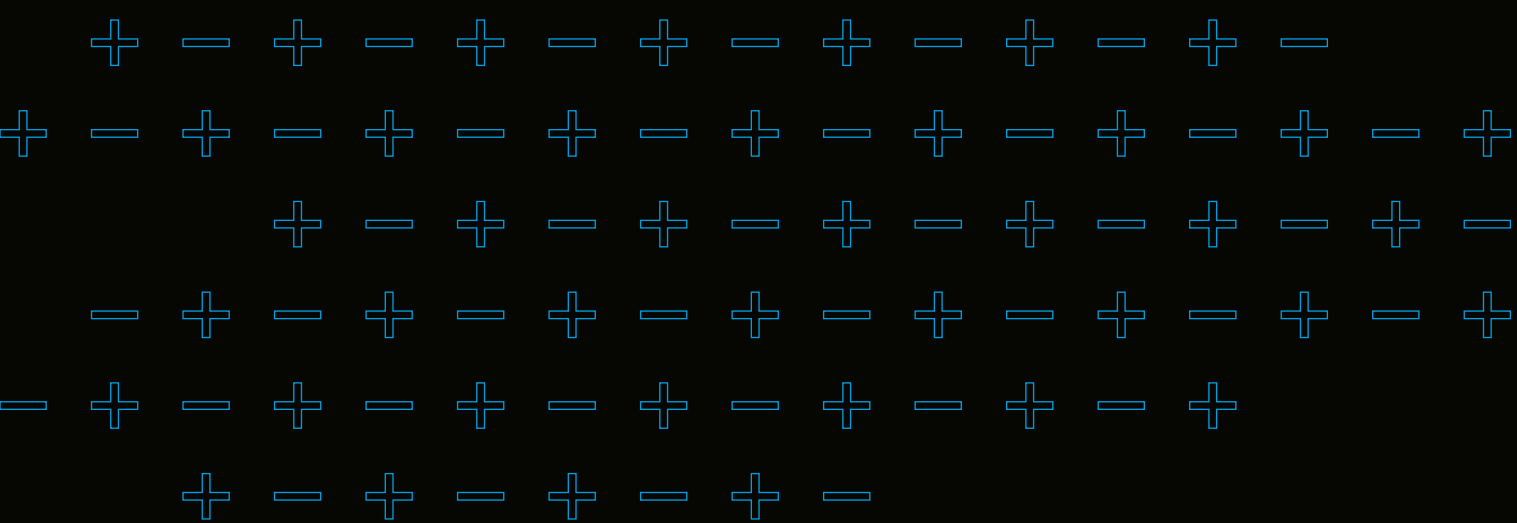
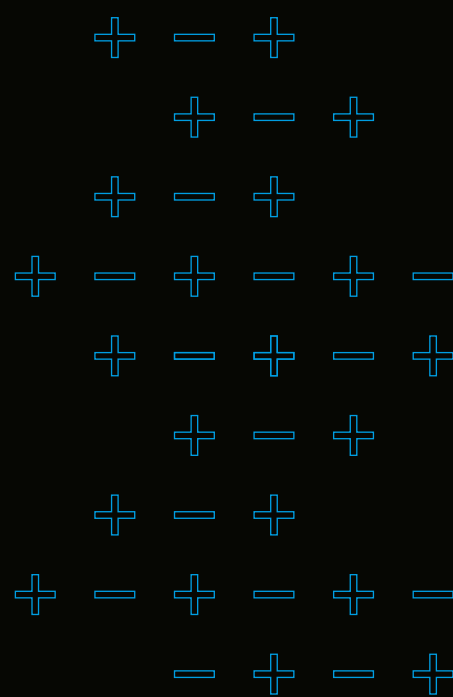

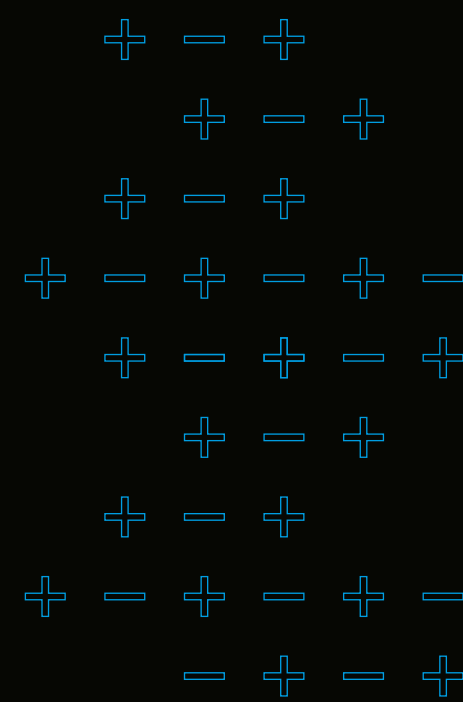

Wireless charging system

- + Your smartphone can be fixed in place in the oddments tray where it is charged wirelessly.
- + Irrespective of the model and brand, compatible smartphones are charged wirelessly.

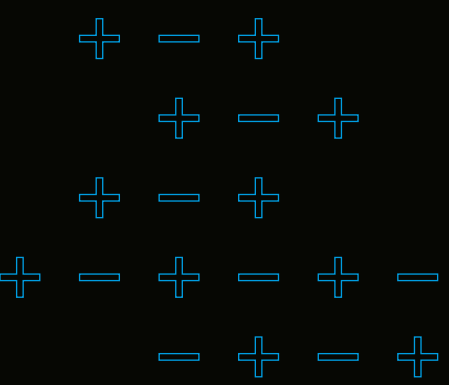

Smartphone Integration

- + Smartphone integration links the mobile phone with the media system via Apple® CarPlay® and Android Auto® giving you convenient access to applications of your smartphone.

+ You can also use apps from third party service providers such as Spotify quickly and easily.

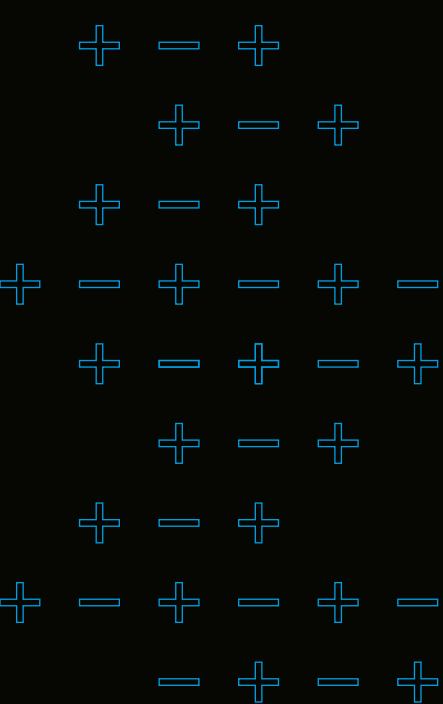

Leather multifunction sports steering wheel

- + The elegant leather lining gives the multifunction sports steering wheel an even higher quality look.
- + As the driver, you enjoy a double benefit: what looks good must also feel good.

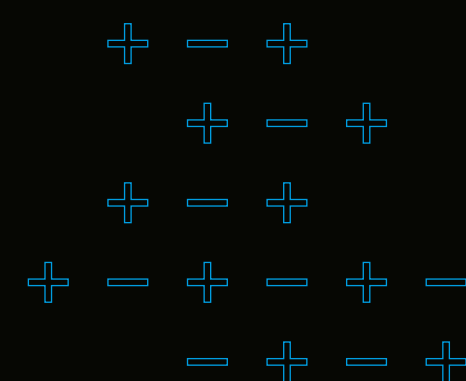

Cruise control

- + Enjoy relaxed, fuel-efficient motoring on longer journeys in particular.
- + You can preselect your desired speed and your vehicle takes over control of the speed.
- + The limiter helps you to observe a maximum speed and ensures road safety.

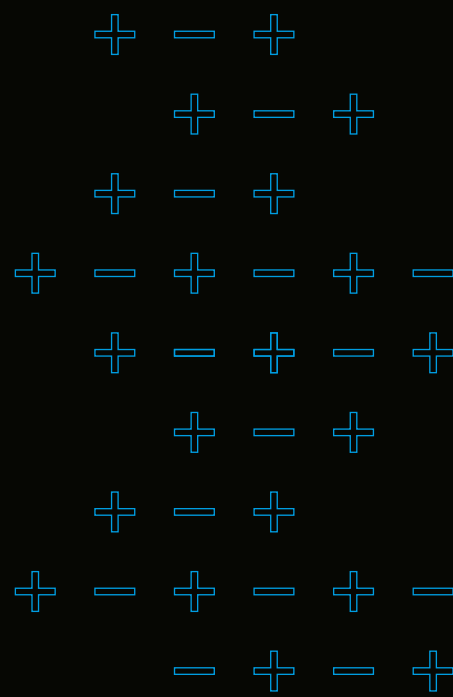

THERMOTRONIC 3-Zone automatic climate control

- + The 3 climate zones and 3 climate styles provides an individual feel-good atmosphere on board.
- + The driver and front passenger are able to set the temperature, air distribution and climate style to suit their personal needs.
- + The third climate zone is in the rear – with separately adjustable temperature and airflow.

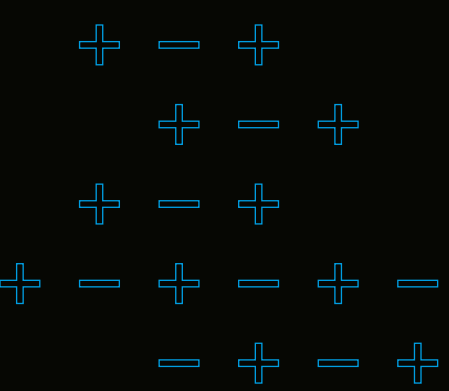

**Please read the disclaimer.*

Touchpad

- + Operates the display of the infotainment system as you would on a smartphone.
- + Shift or enlarge the content quite simply with single gestures.
- + The touchpad recognises your handwriting should you wish to enter addresses or phone numbers

**Please read the disclaimer.*



Power front right seat with memory function

- + The incorporated Memory function is particularly practical if you have a regular front passenger or you yourself often take to the front passenger seat.

Driver's seat, electrically adjustable with memory function

- + Comfortable and individual adjustment of the seating position and head restraint is made possible by the electrically adjustable driver's seat.
- + The included memory function is particularly useful if different drivers use your vehicle and the seat adjustments are changed frequently.

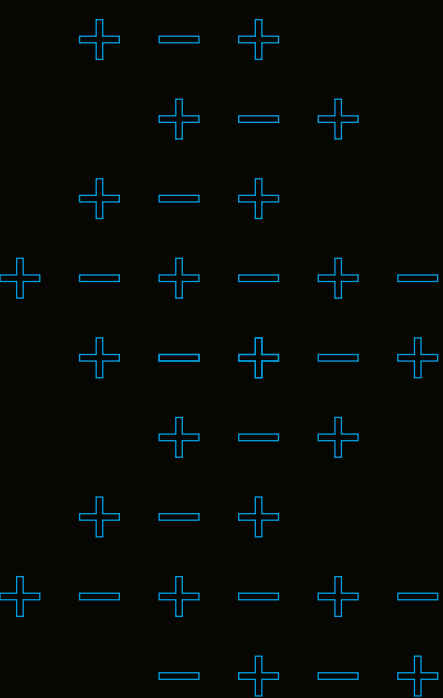

Burmester® surround sound system

- + The high-performance speakers develop first-class surround sound.
- + You can specifically optimise this for the front and rear seats to intensify the listening experience.

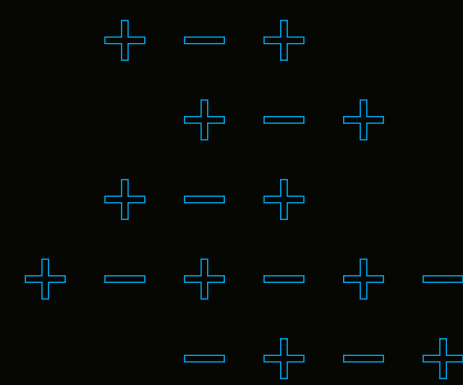

Heat and noise-insulating acoustic glass

- + The glass for the front side windows provides you with even greater noise comfort.
- + Thanks to reduced background noise, you can enjoy an even quieter ambience on your journey – while on the other music lovers can benefit from enhanced listening pleasure.

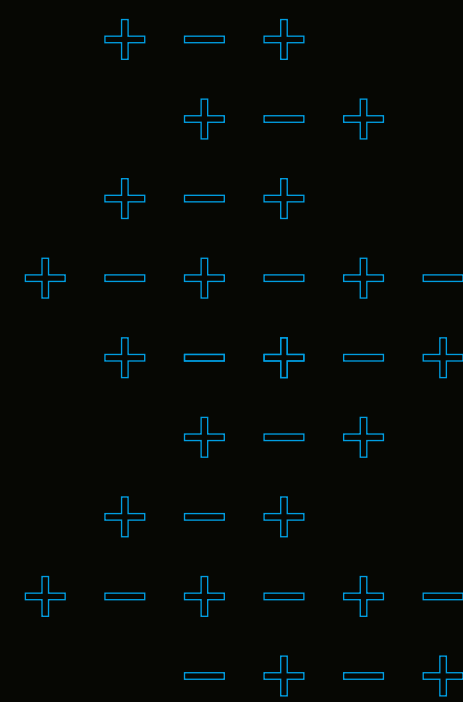

AIR-BALANCE package

The ionisation and filtering of the outside and interior air, helps to ensure improved air quality and a greater sense of well-being and provides an individual personalised fragrance in the interior.

- + Fragrance generator with filled fragrance flask and function cap in the glove compartment
- + Oxygen ioniser in the side air duct
- + Improved filter system between the air conditioner's intake and air distribution system

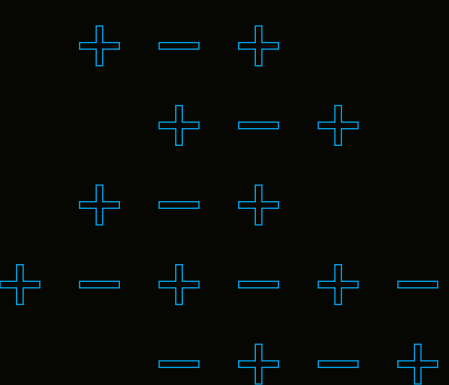

4-way lumbar support

- + The 4-way lumbar support is a small detail which has a big impact.
- + It adjusts the seat contour to your lumbar area and provides support.
- + Four settings are possible: higher, lower weaker or stronger.

**Please read the disclaimer.*

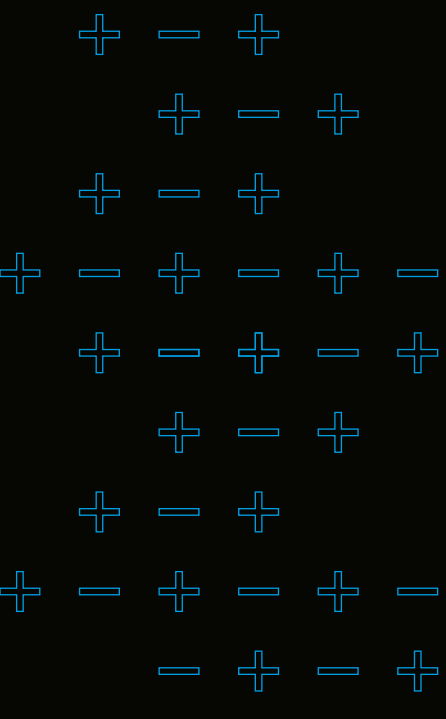

Preinstallation for entertainment and comfort features

- + It allows you to easily connect a variety of equipments and accessory products.
- + The system attaches to the backrests of the front seats and features an integral power supply – for undisturbed entertainment on longer journeys.

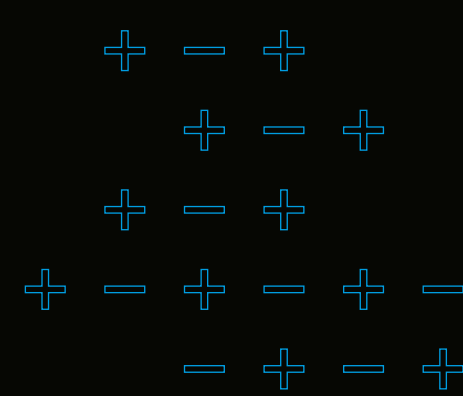

Roller sunblinds

- + The manual pull-out roller sunblinds protect against direct, bright sunlight in summer and when the sun is low in the sky.
- + It still remains possible to see out of the rear windows – for a pleasant and eventful journey.



Stowage Space package

It provides stowage and securing options for the interior and beneath the luggage compartment floor. The luggage compartment becomes a mini source of power: on board is a 12 V socket and twin USB charging ports.

- + Collapsible crate under load compartment floor
- + 12 V socket on the left of the luggage compartment
- + Map pockets on the backs of the front seats
- + Stowage compartment under load compartment floor lockable
- + Twin USB charging ports in the rear (Type C)

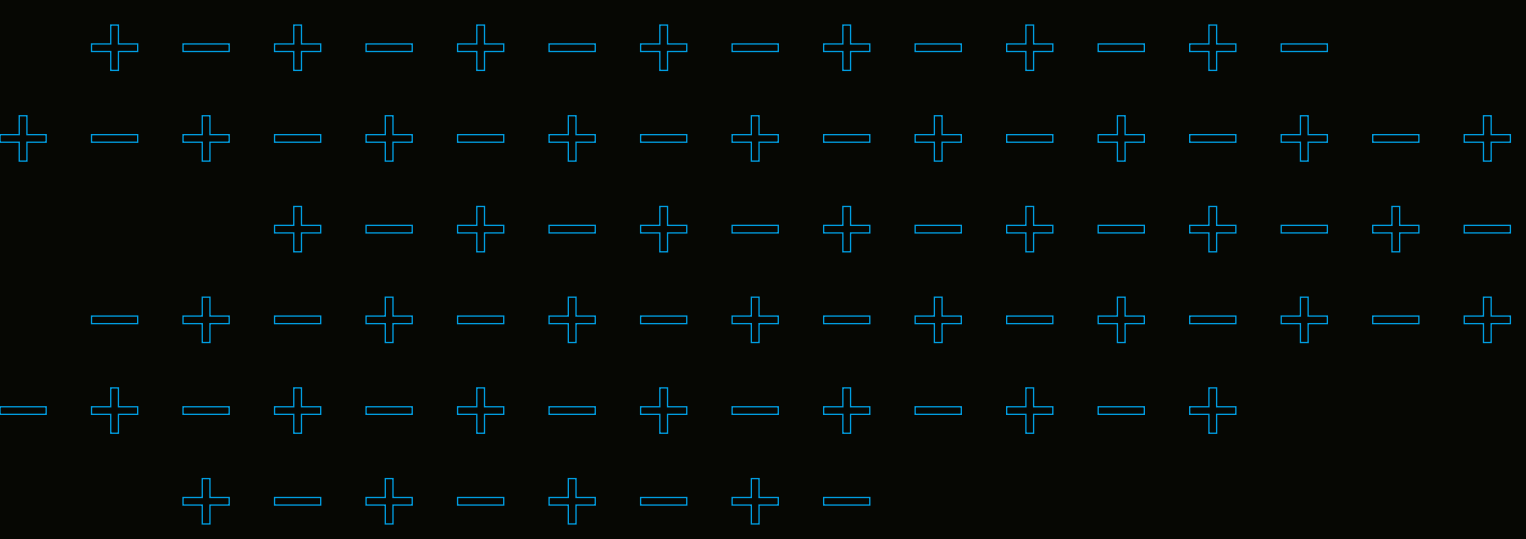
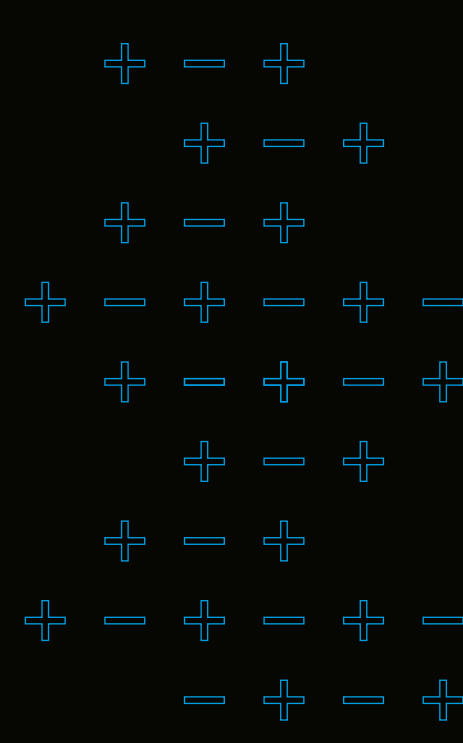

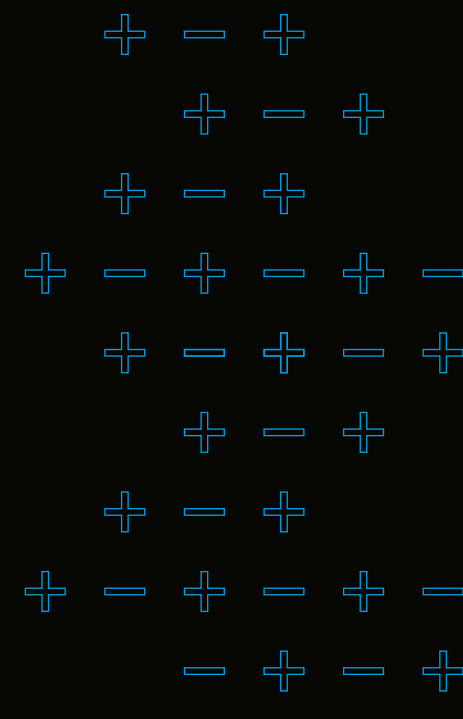

EASY-PACK load compartment cover

- + It comprises of a retractable cover which is fitted behind the rear seats.
- + You can remove this at any time and store it in the compartment provided beneath the load compartment floor.

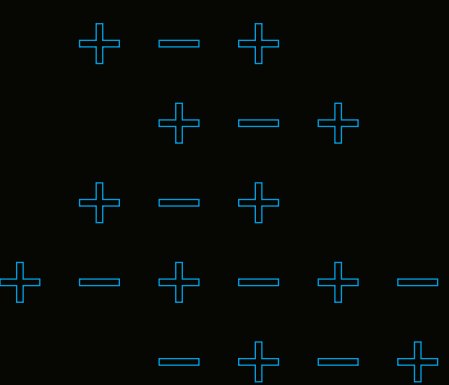
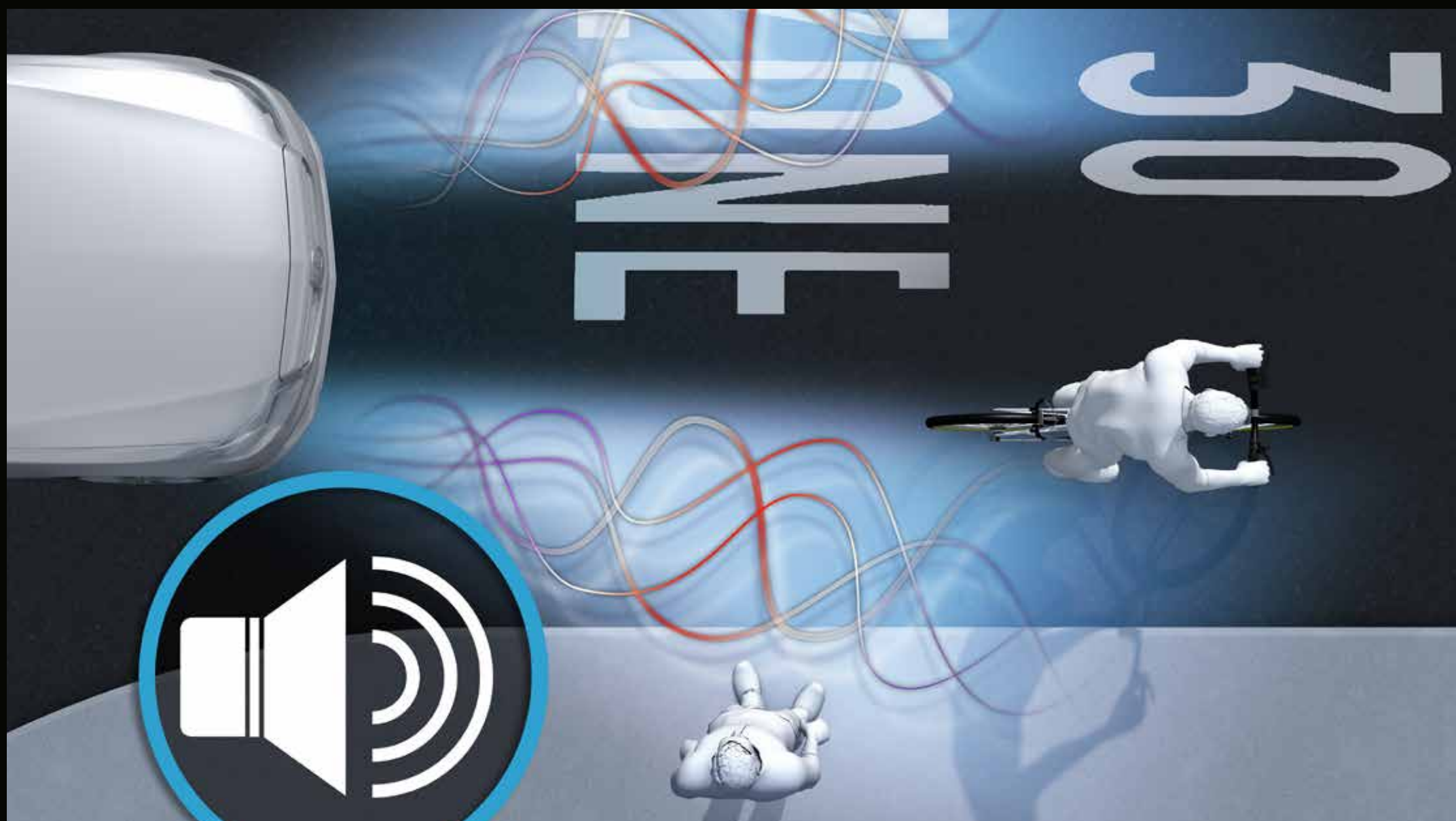

Acoustic ambient protection

- + So that your vehicle does not pose a danger to pedestrians and cyclists when driving in virtually silent all-electric mode, the acoustic environmental protection generates a specific Mercedes-Benz sound outside of the vehicle up to a speed of 30 km/h.

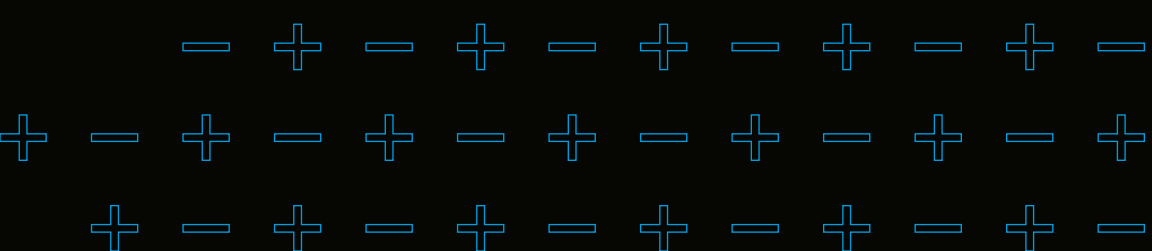

**Please read the disclaimer.*

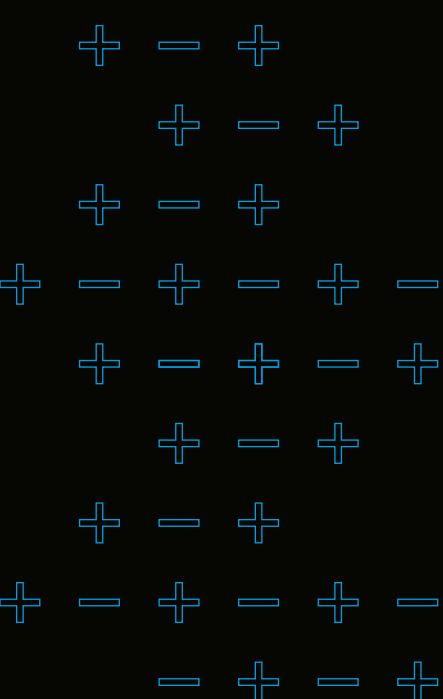

Velour floor mats

- + They are finished in black and feature elegant topstitching in the respective appointments colour.
- + They protect the footwell against dirt and can be removed easily to be hoovered or cleaned.

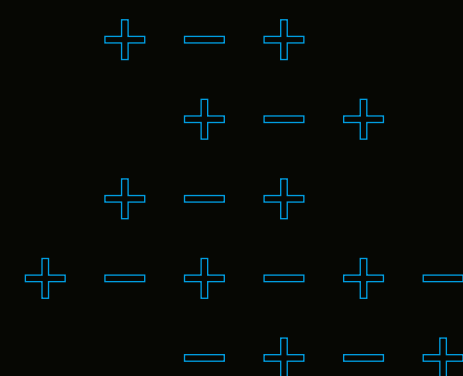

Door sill panels with model series-specific lettering, illuminated

- + The high-quality stainless steel sill panels are illuminated with striking model series-specific lettering enhancing your getting in and getting out experience.
- + This is coloured in blue and thus supplements the host of specific exterior features which are also in this colour.

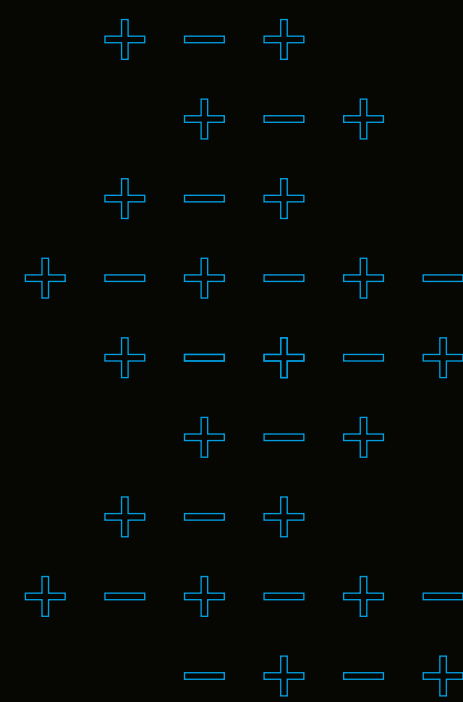

KEYLESS-GO Comfort package

- + You can start and lock your vehicle simply by having the key on your person.
- + The HANDS-FREE ACCESS function allows contactless, fully automatic opening and closing of the luggage compartment.
- + KEYLESS-GO access and drive authorisation system
- + Door handles with chrome inserts

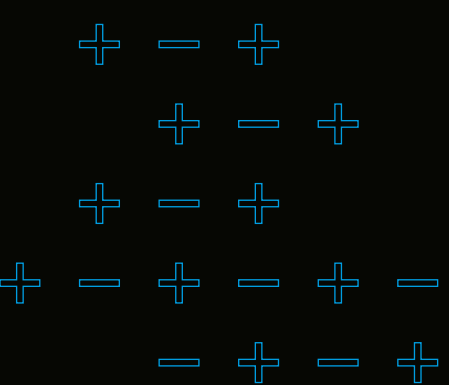

EASY-PACK tailgate

- + Extremely practical: the EASY-PACK tailgate can be opened and closed electrically and makes loading and unloading the boot even more convenient.
- + You can start the opening and closing process very conveniently at the press of a button and interrupt it at any time by pressing the button again.

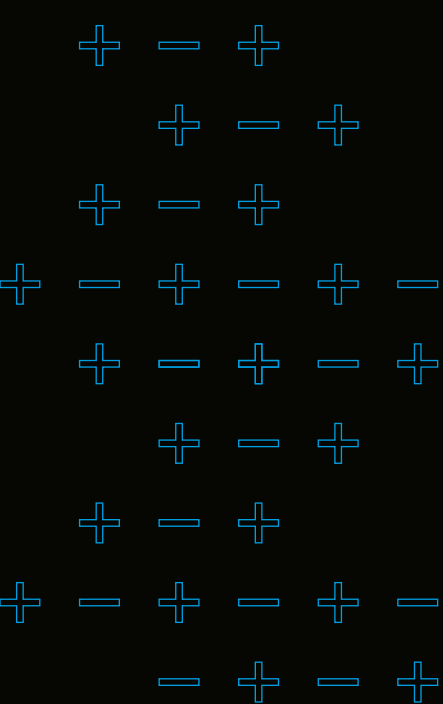

Media Interface cable kit

- + The direct link to your data: with the practical cable kit you can connect your devices with USB or Lightning port to your vehicle's multimedia system via a universal interface.
- + Simply connect your smartphone or tablet via cable and access the required content.

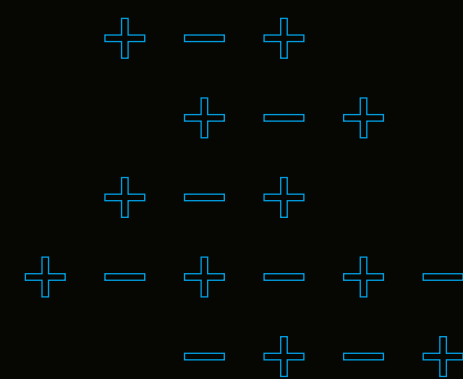

Plug-in module for luggage compartment (telescopic rods)

- + You can divide up the luggage compartment of your vehicle flexibly so as to stow your luggage.
- + Fragile items and sensitive objects can thus be transported more safely.

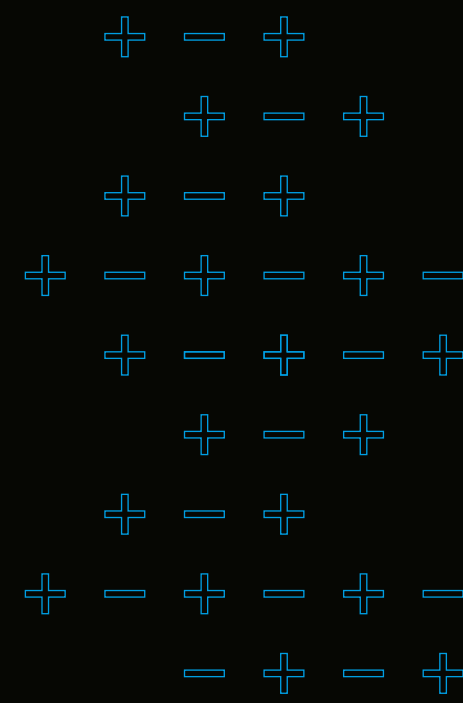

Emergency spare wheel

- + The narrow emergency wheel is lightweight and makes changing a tyre in the event of a breakdown simple.
- + This enables you to reach the next service station even in the event of more significant tyre damage which it may not be possible to repair with TIREFIT tyre sealant.

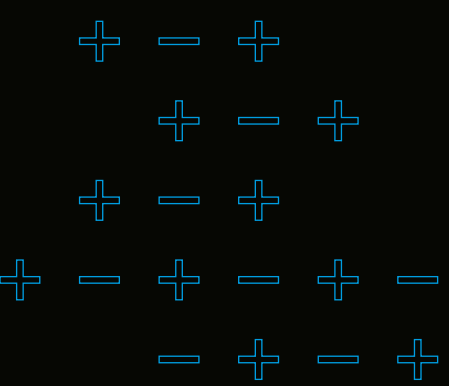

TIREFIT

- + Damage caused by driving over nails or glass fragments can be sealed by means of the sealant blown in via the air compressor.
- + As a result you can continue to drive to the nearest workshop at up to 80 km/h.

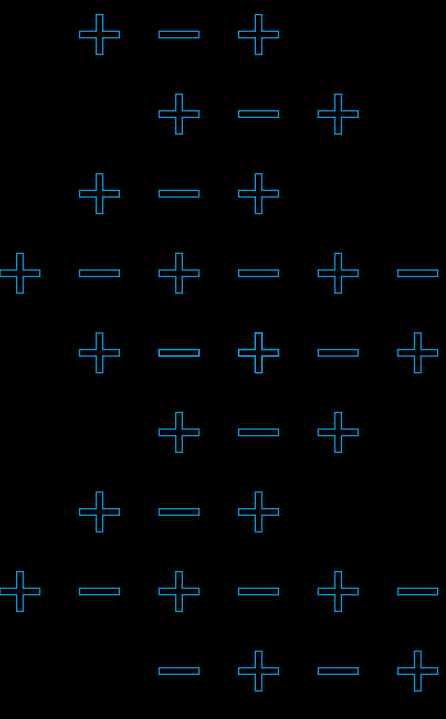

Tyre-change toolkit

+ Changing a wheel is much simpler thanks to the tyre-change tool kit, which makes removing wheel nuts a quick and simple task.

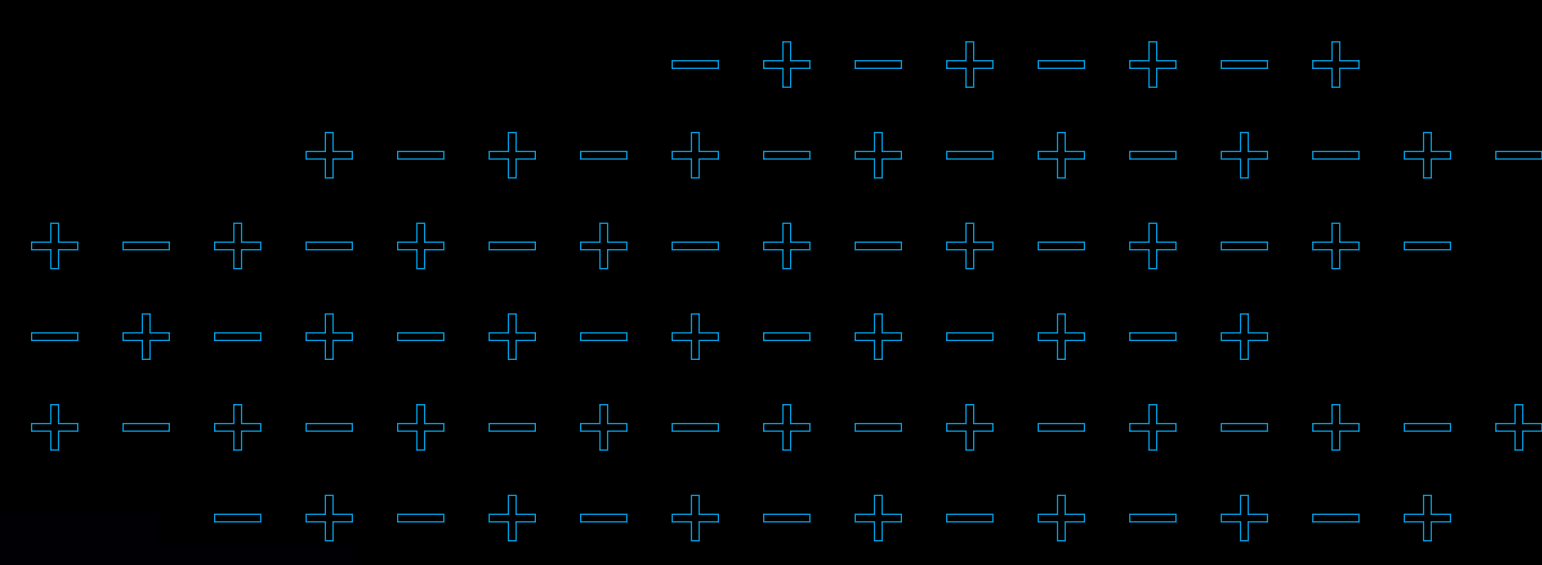
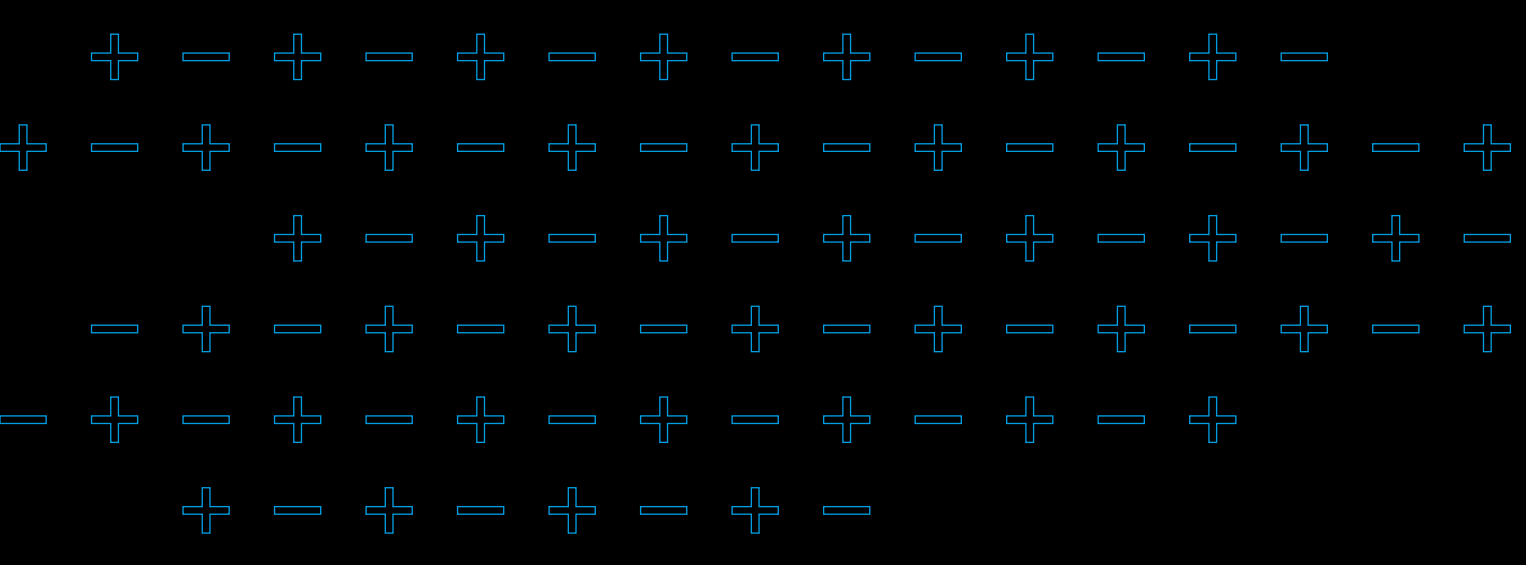

Mercedes me connect

Stay in touch with your vehicles from anywhere in the world, and obtain assistance at the touch of a button.

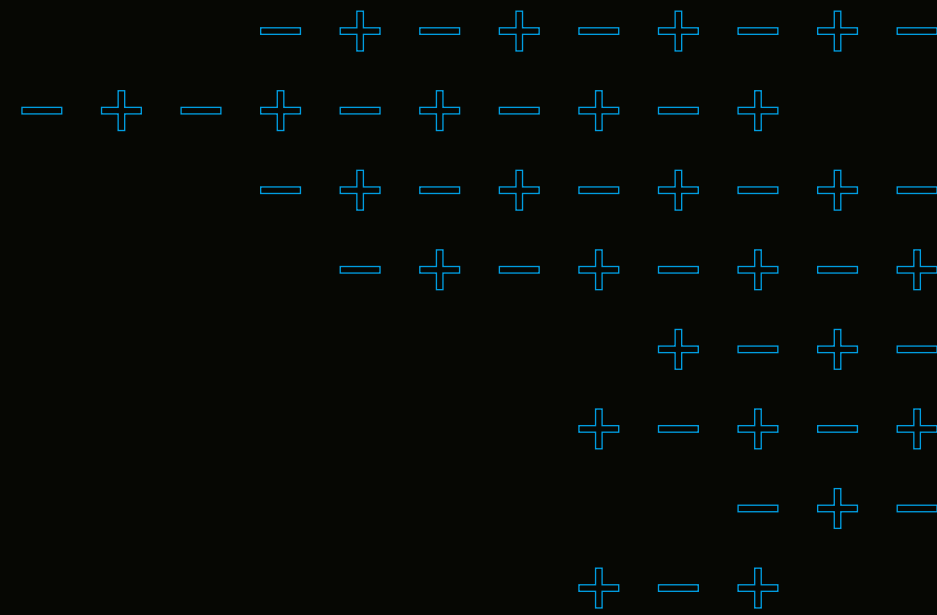

Vehicle Monitoring

- + Locates and directs you to your parked vehicle within a radius of 1.5 km.
- + You can get your vehicle's geocoordinates sent by GPS.
- + Receives alert notifications if the vehicle exceeds the set speed.

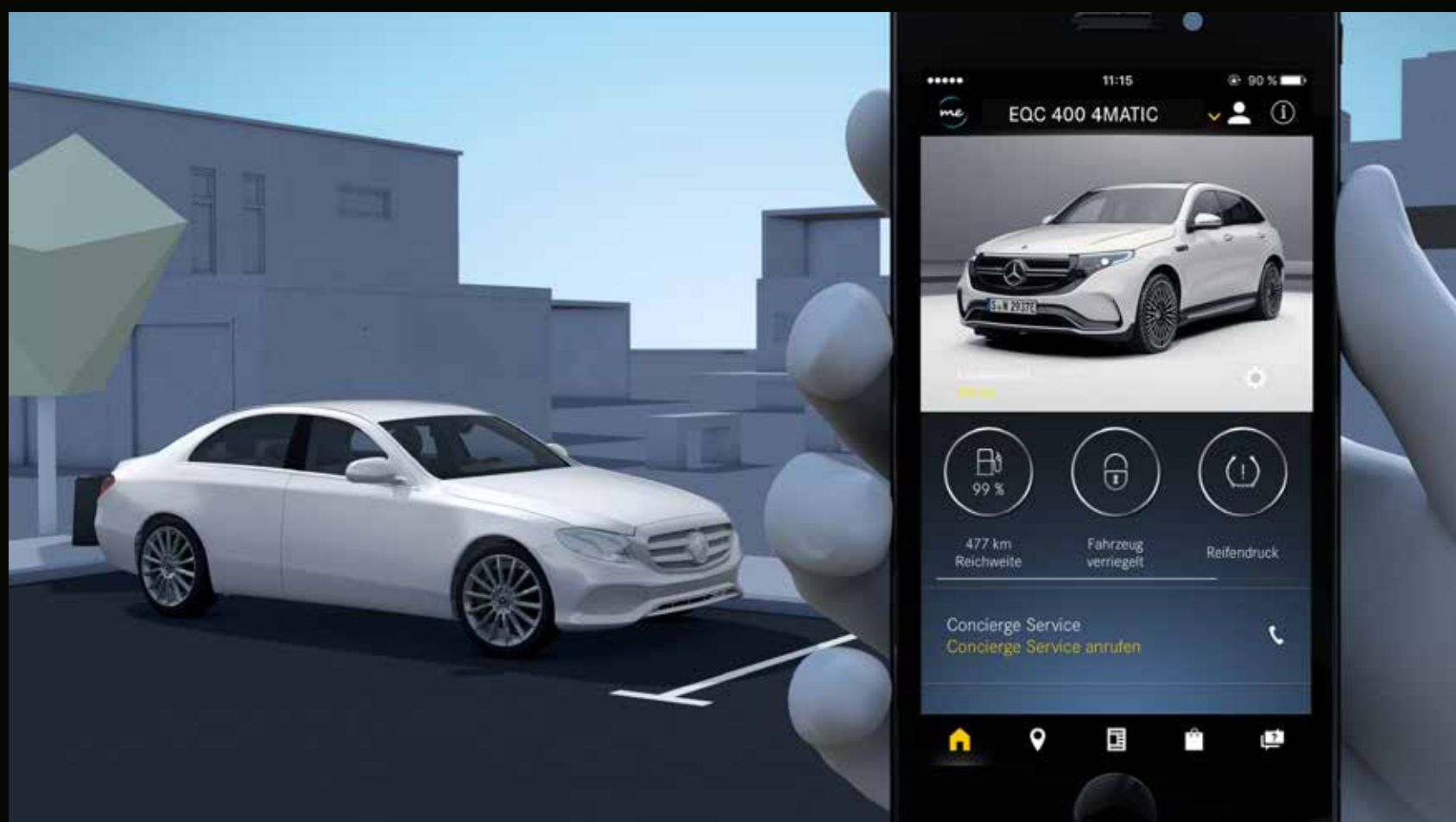
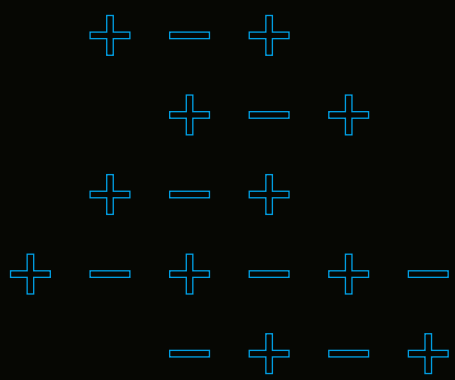

Vehicle Set-up

- + Receives traffic information in real time and optimises dynamic route guidance.

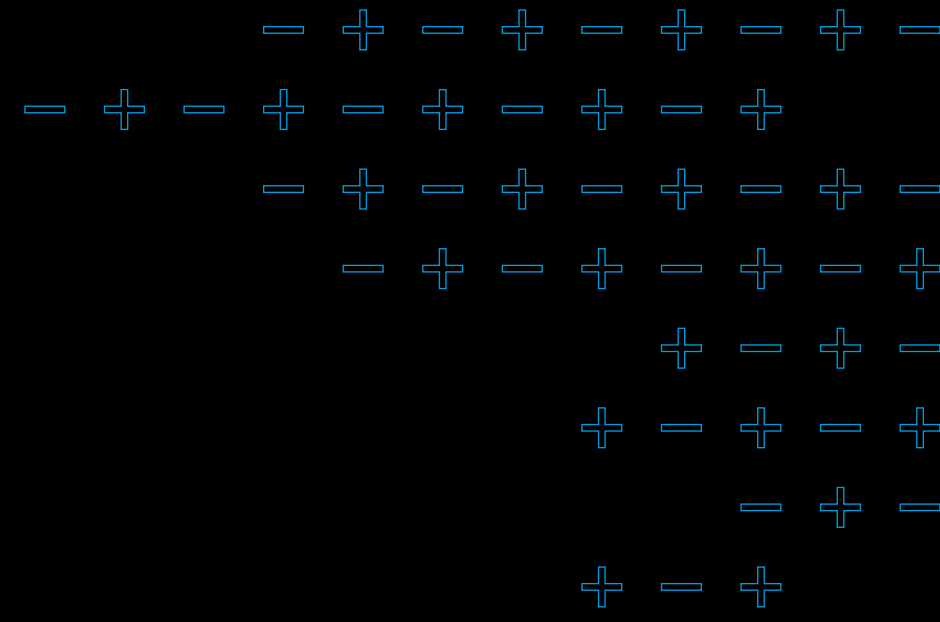

Navigation Connectivity Package

- + The hard disc navigation makes sure that you always reach your destination as quickly as possible by the best route.

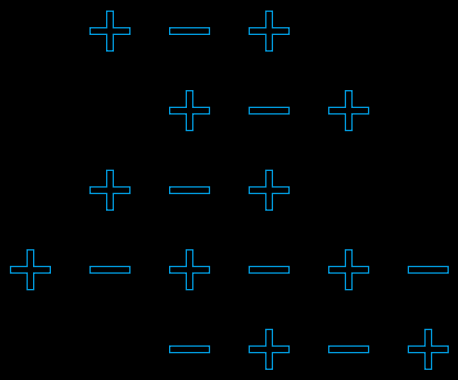

Mercedes-Benz Emergency Call System

- + In case of an accident, a communications module with its own SIM card automatically triggers an emergency call.



**Please read the disclaimer.*

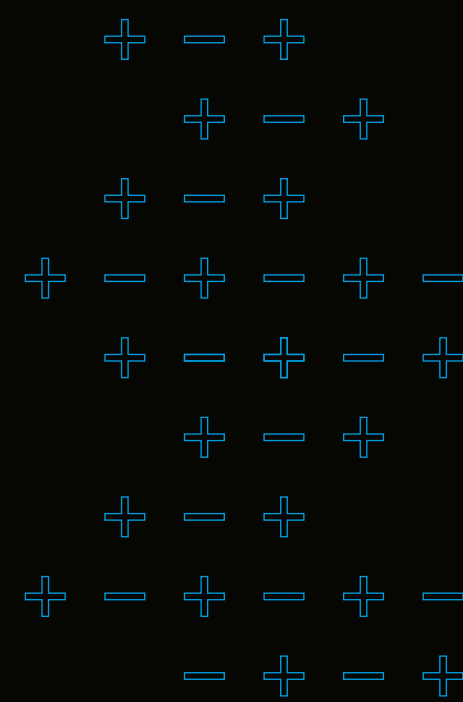

Parking Package with 360-degree camera

- + Active Parking Assist with 360° camera makes it easier for you to find a parking space and to manoeuvre into and out of parking spaces.
- + The all-round visibility helps you have your vehicle parked stress-free.

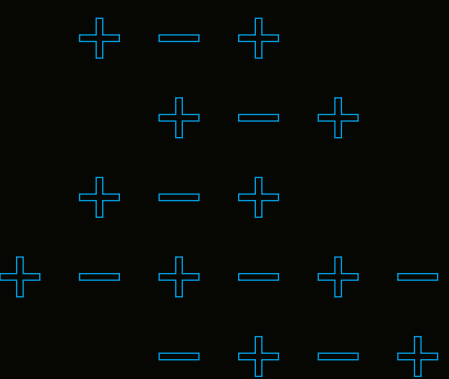
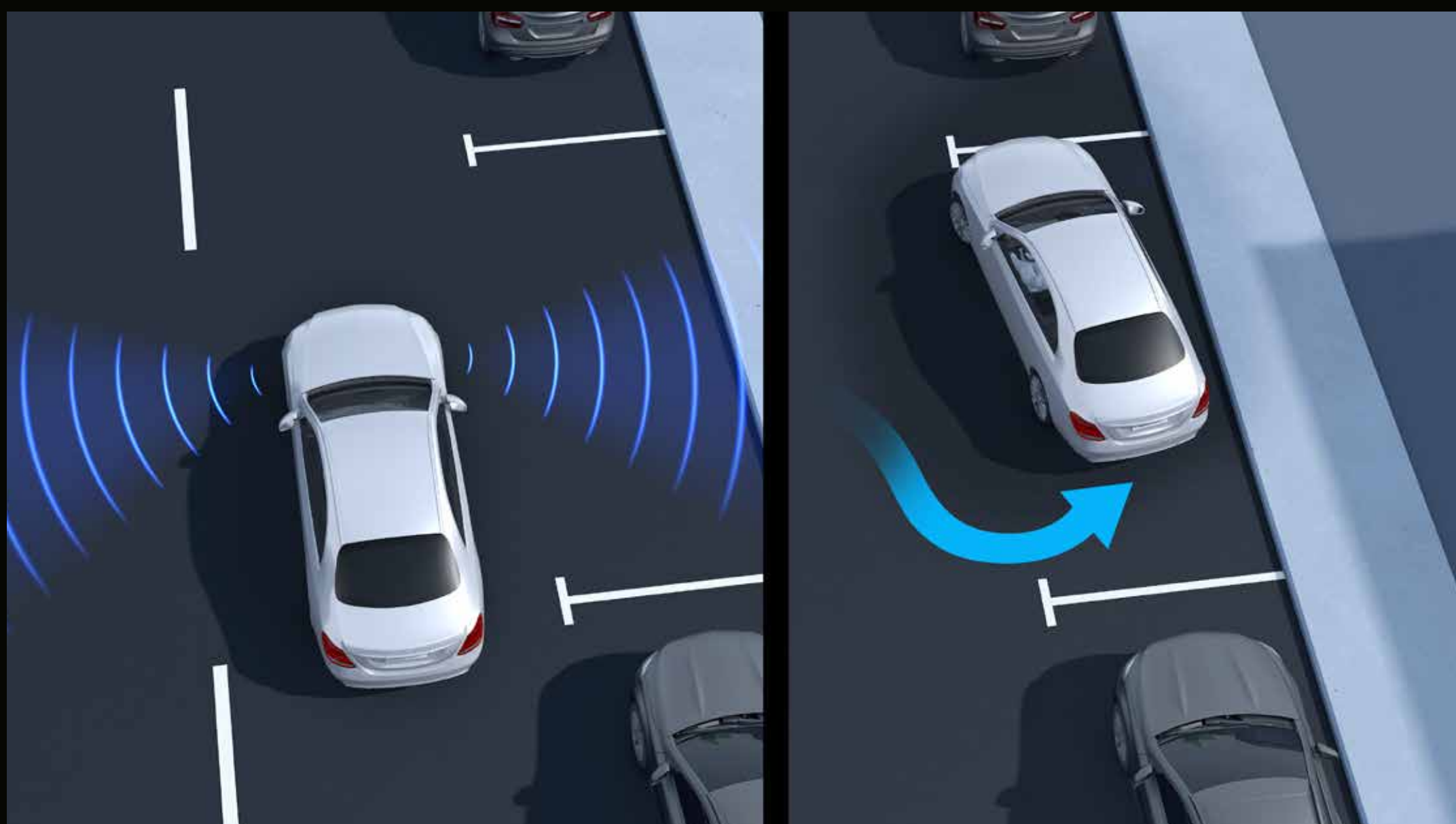

Active Parking Assist with PARKTRONIC

- + It not only finds parking spaces but also helps you to enter and leave them.
- + As part of this it helps you with steering, and on vehicles with automatic transmission also with accelerating, braking and changing gear.



Anti-Theft Protection package with preinstallation for collision detection

It gives an audible and visual warning when it detects a break-in or an attempted theft.

- + Anti-theft alarm system
- + Interior monitoring system (triggered when there is movement in the interior)

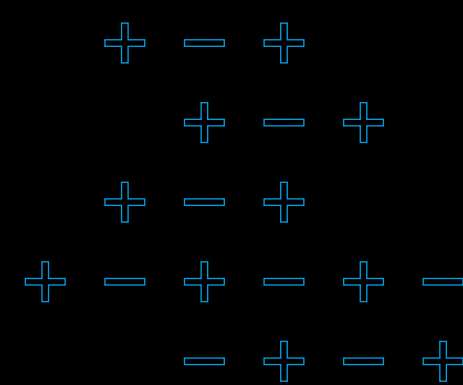

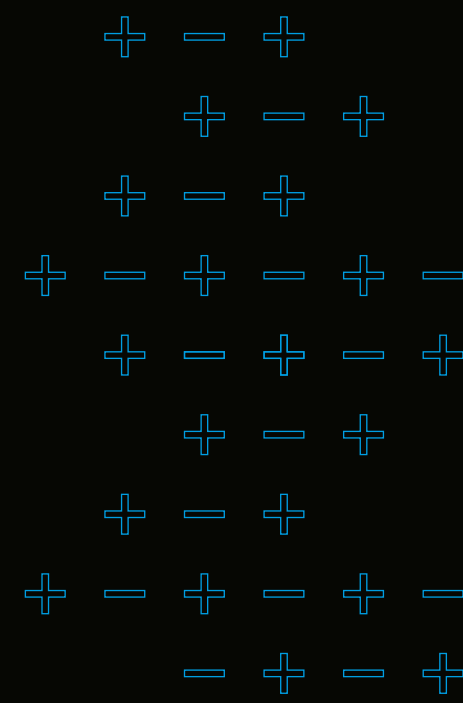
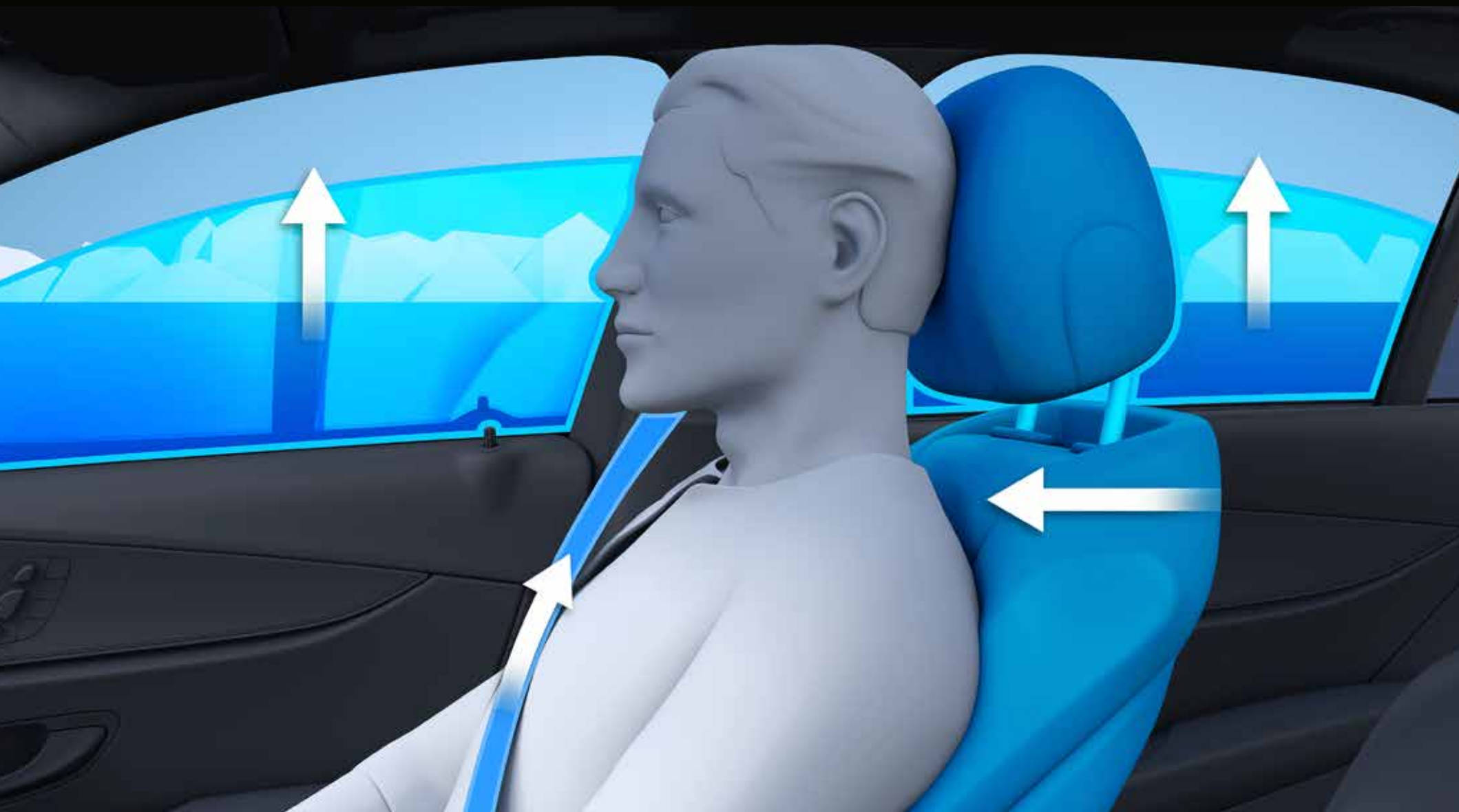

PRE-SAFE® system

- + Makes use of the time prior to an impending accident on your behalf.
- + The innovative PRE-SAFE® Sound generates a noise from the speakers which is able to trigger a protective reflex: your hearing briefly disconnects, thus protecting itself from the loud noises of the crash.

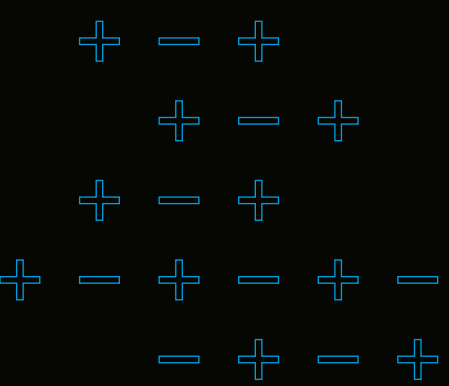

Sidebags in rear

- + The side airbags in the rear protect the chest area on the outer rear seats in the event of a severe side impact.
- + Together with the standard windowbags you therefore have optimum safety potential for preventing or lessening injuries.
- + The air cushions slide between the side of the door and the occupant.

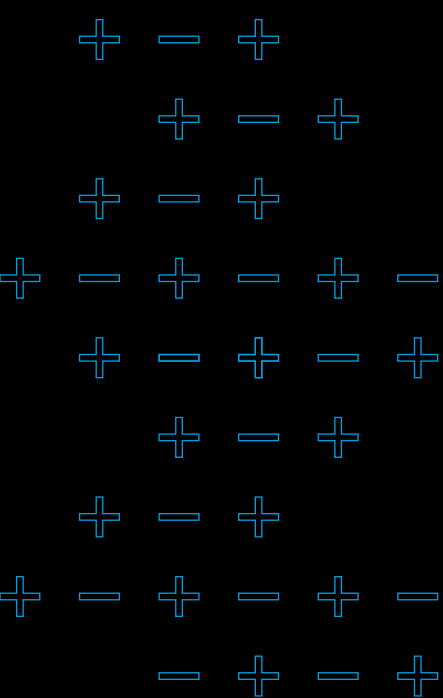

Kneebag

- + The kneebag protects your legs from contact with the steering column or the dashboard in a severe frontal crash.
- + This can prevent or lessen the severity of injuries.
- + The air cushion inflates in milliseconds and stabilises the whole body.
- + This ensures that the entire restraint system including the seat belt work together optimally.

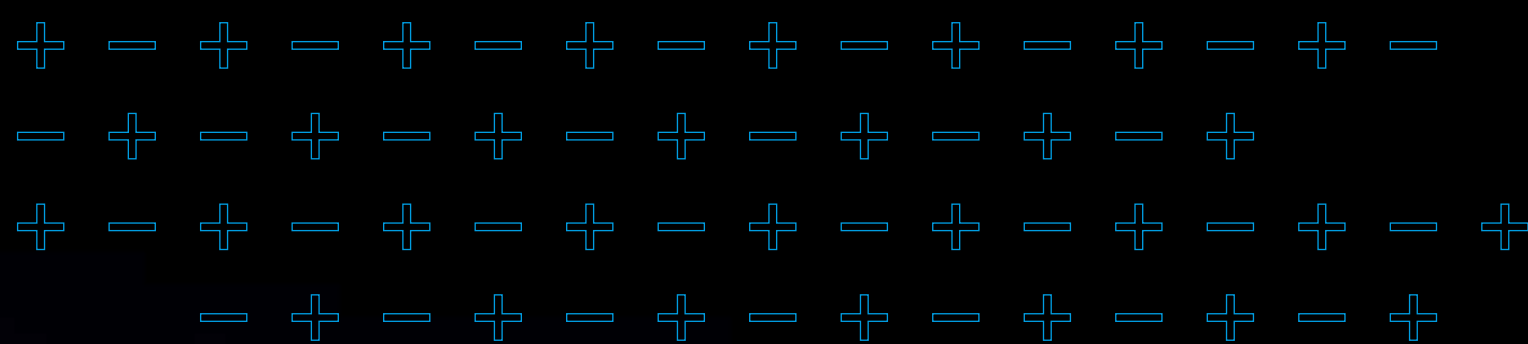

Paint



Polar White



High-Tech Silver



Graphite Grey

Trim and Upholstery



Grey matrix-look trim



Aluminium-look trim



ARTICO man-made leather/Sunnyvale fabric, two-tone indigo blue/black



ARTICO man-made leather / Sunnyvale fabric, two-tone silk beige / black

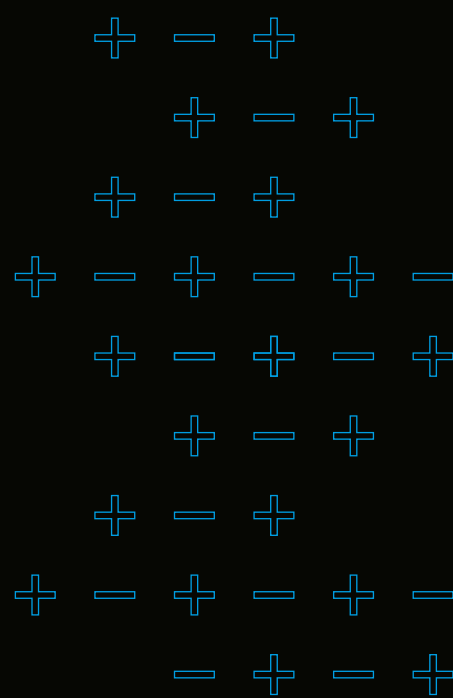

Alloy



50.8 cm (20-inch) 10-spoke light-alloy wheels, painted in high-gloss black with energy blue decorative elements and a highsheen finish

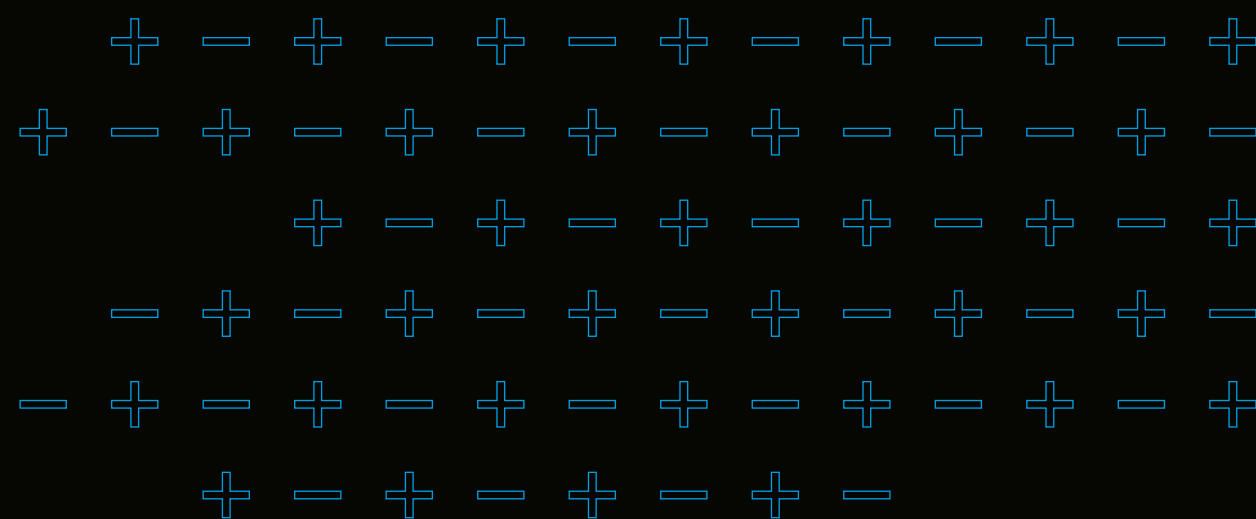

Dimensions

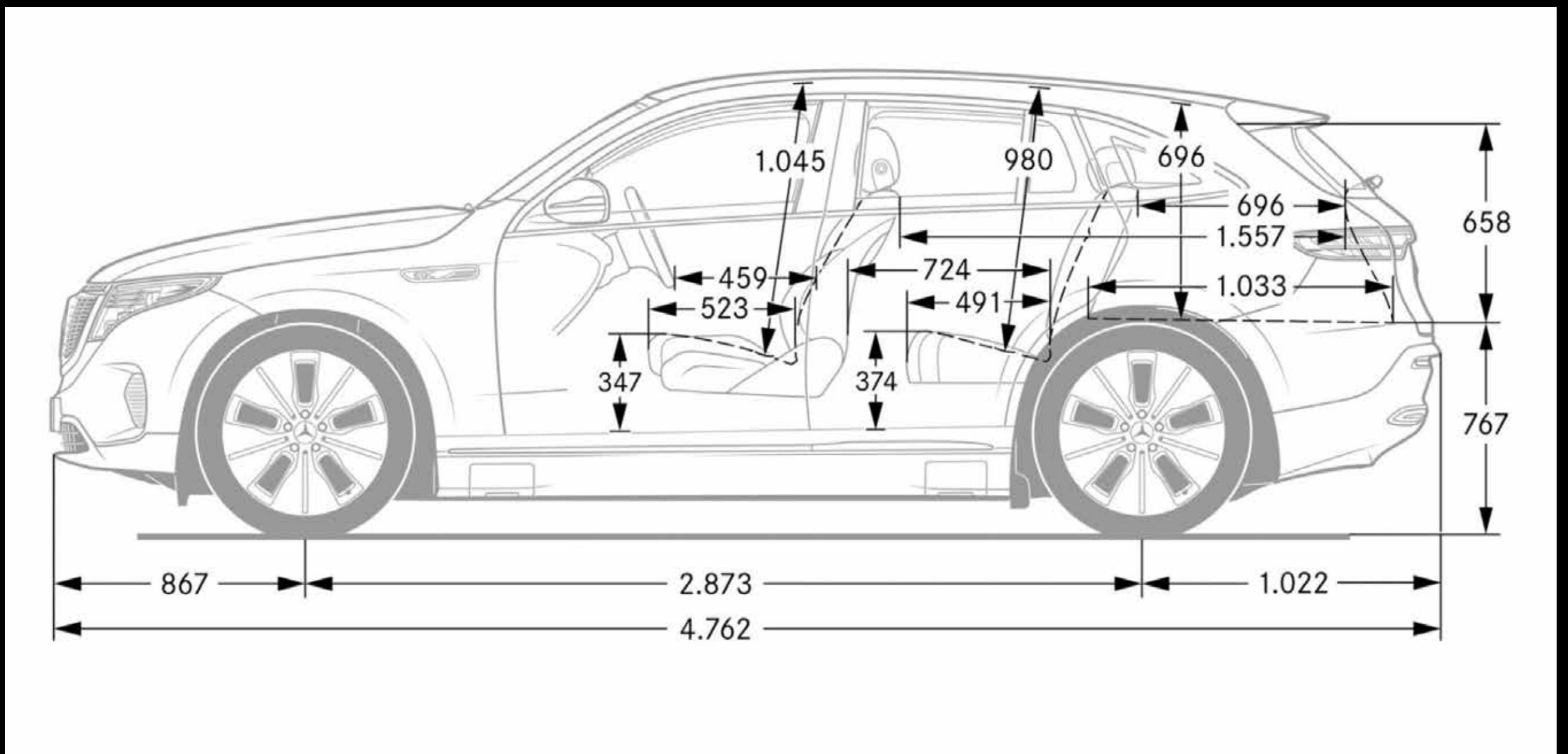
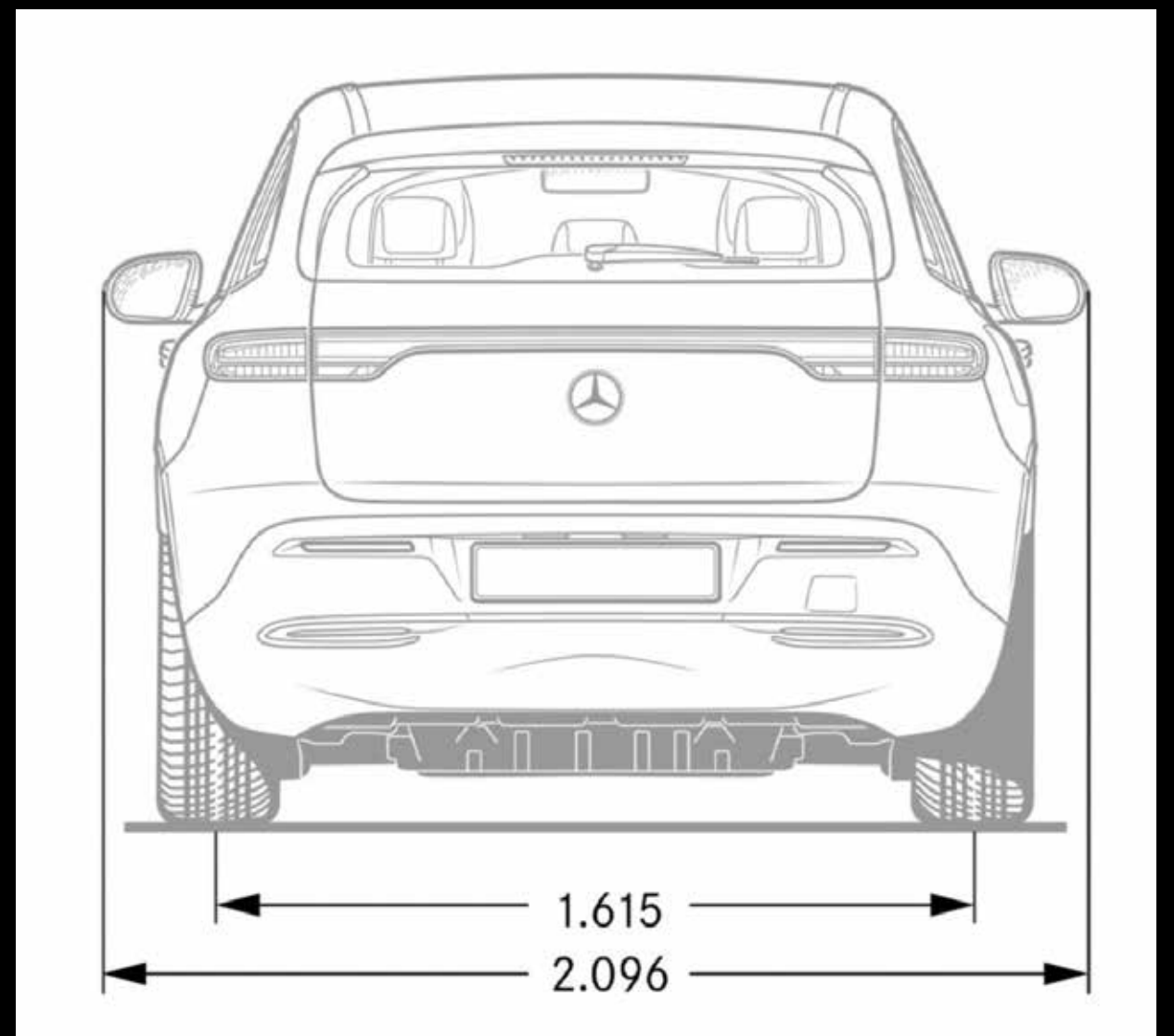
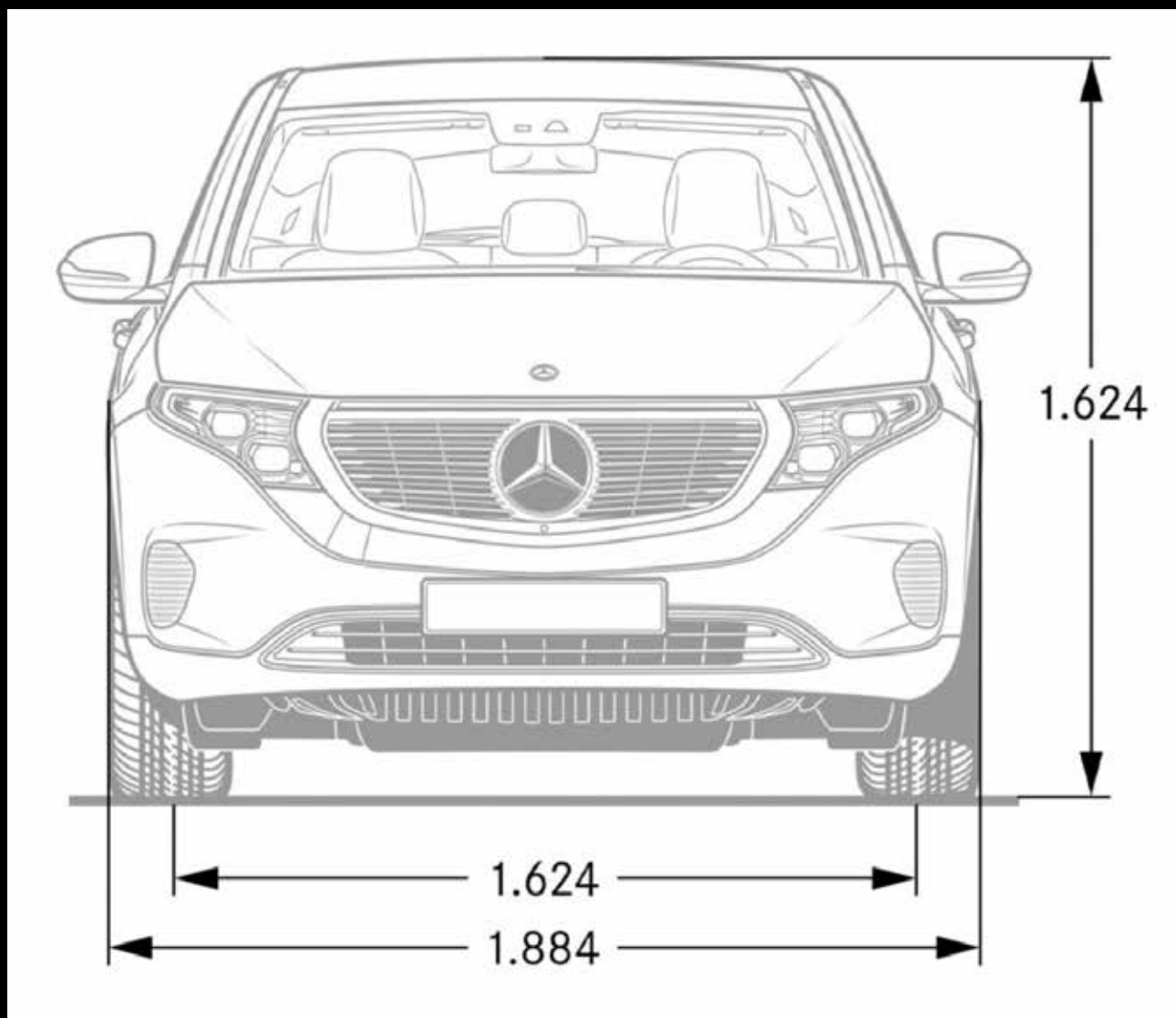

All figures in millimetres. The illustrated dimensions are mean values. They are valid for vehicles in basic specification and in unladen condition.

*Please read the disclaimer.

Technical data

Model	EQC 400 4MATIC
Motor	Two asynchronous three-phase AC motors, one each at front and rear axle
Transmission	Single-speed transmission
Drive system layout	4MATIC, infinitely variable torque split
System output	300 kW (408 hp)
System torque	760 Nm
Acceleration 0-100 km/h	5.1 s
Maximum design speed	180 km/h
*Range	370-414 km
Power consumption	20.8-19.7 kWh/100 km

Battery-specific data

Type	Lithium-ion
Cells and modules	384 cells in 6 modules
Battery capacity (usable as per WLTP)	80 kWh
Battery weight	652 kg

**Indicated range is as per the Whole Vehicle Type Approval Certificate issued by European Union (as per WLTP cycle). The actual range may vary based on real driving conditions.*

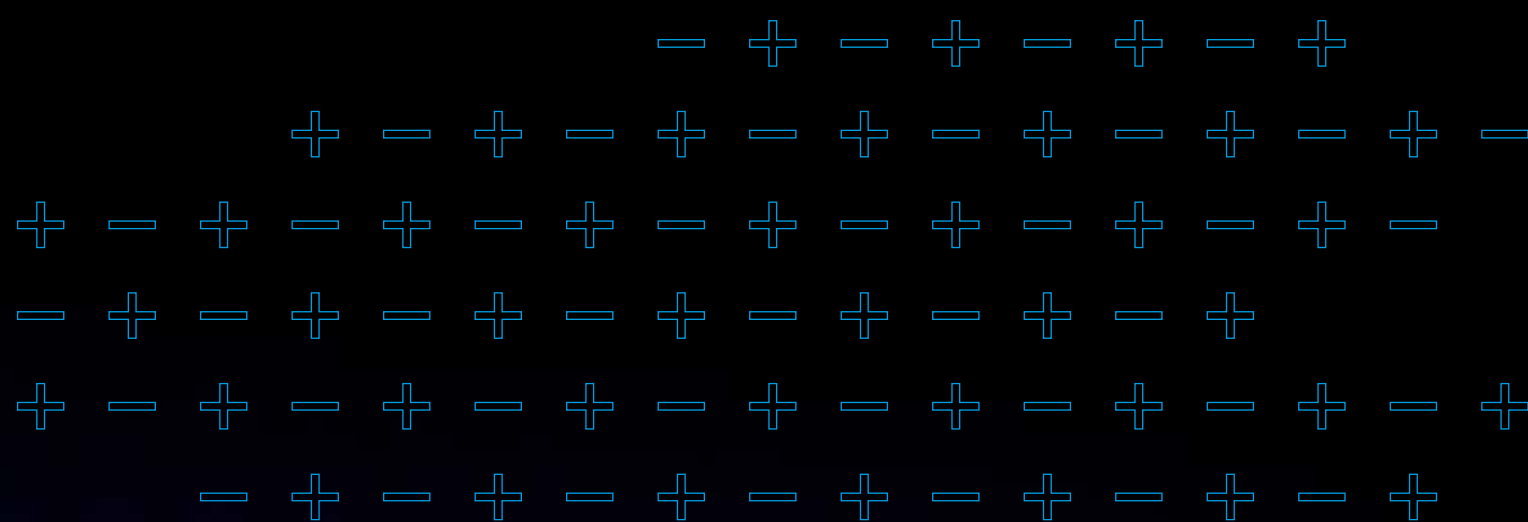

**Please read the disclaimer.*

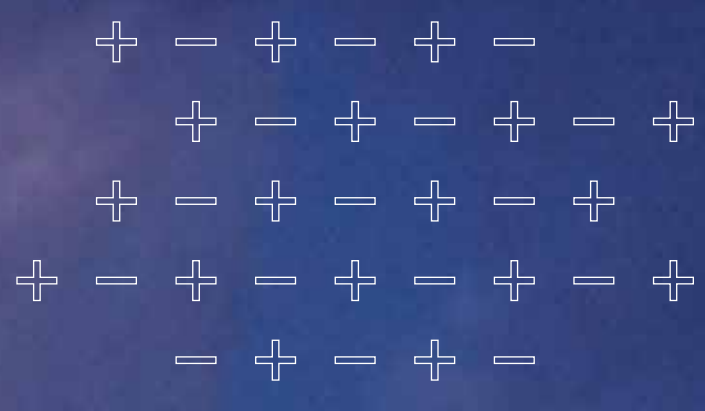

An effortless Star experience is yours.



5 years Unlimited KM
Integrated Warranty



5 years Unlimited KM
Roadside Assistance



5 years Unlimited KM
Service Package



Installation of Wallbox
at your preferred location by
MB Authorized personnel only



8 years
Battery Cover

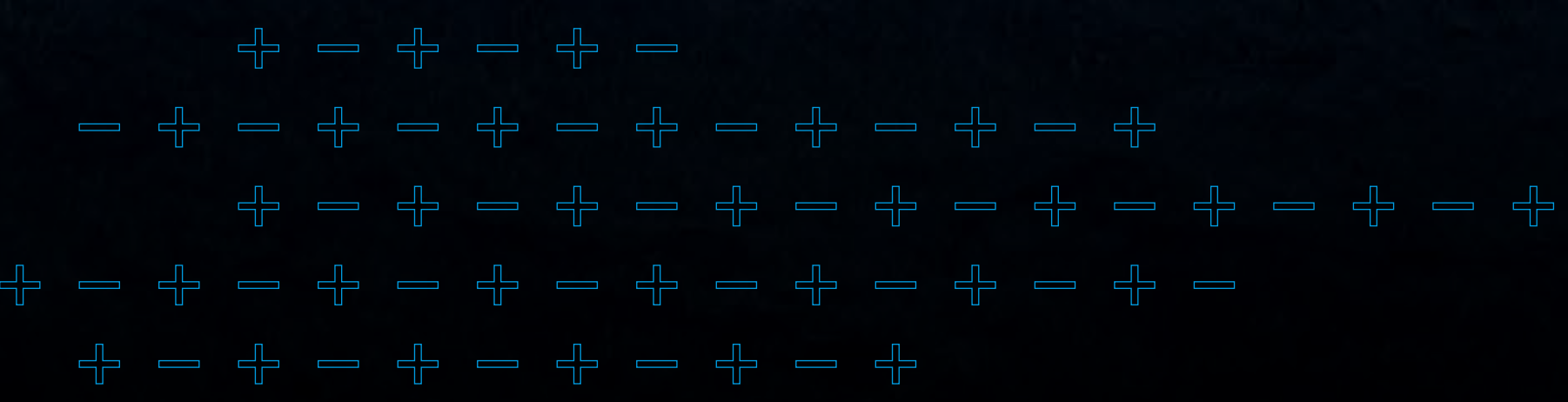
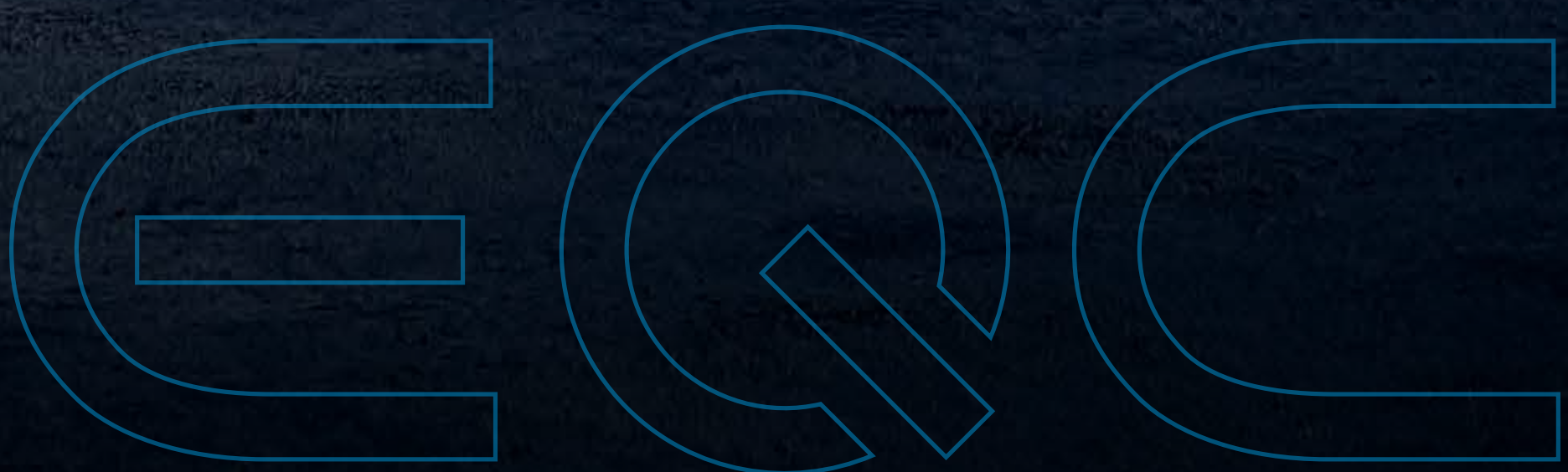

**Please read the disclaimer.*

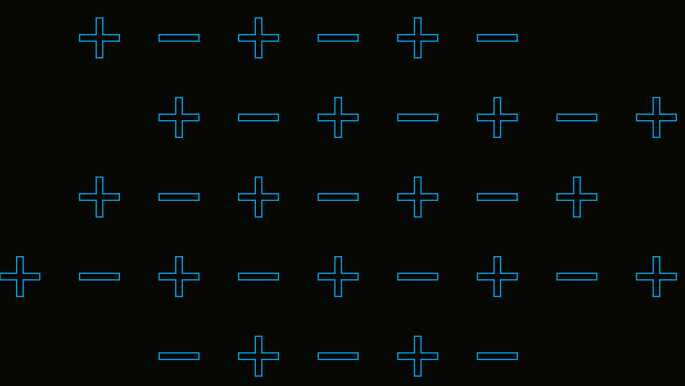

Your Nation-wide EQ dealerships and EQ charging stations.

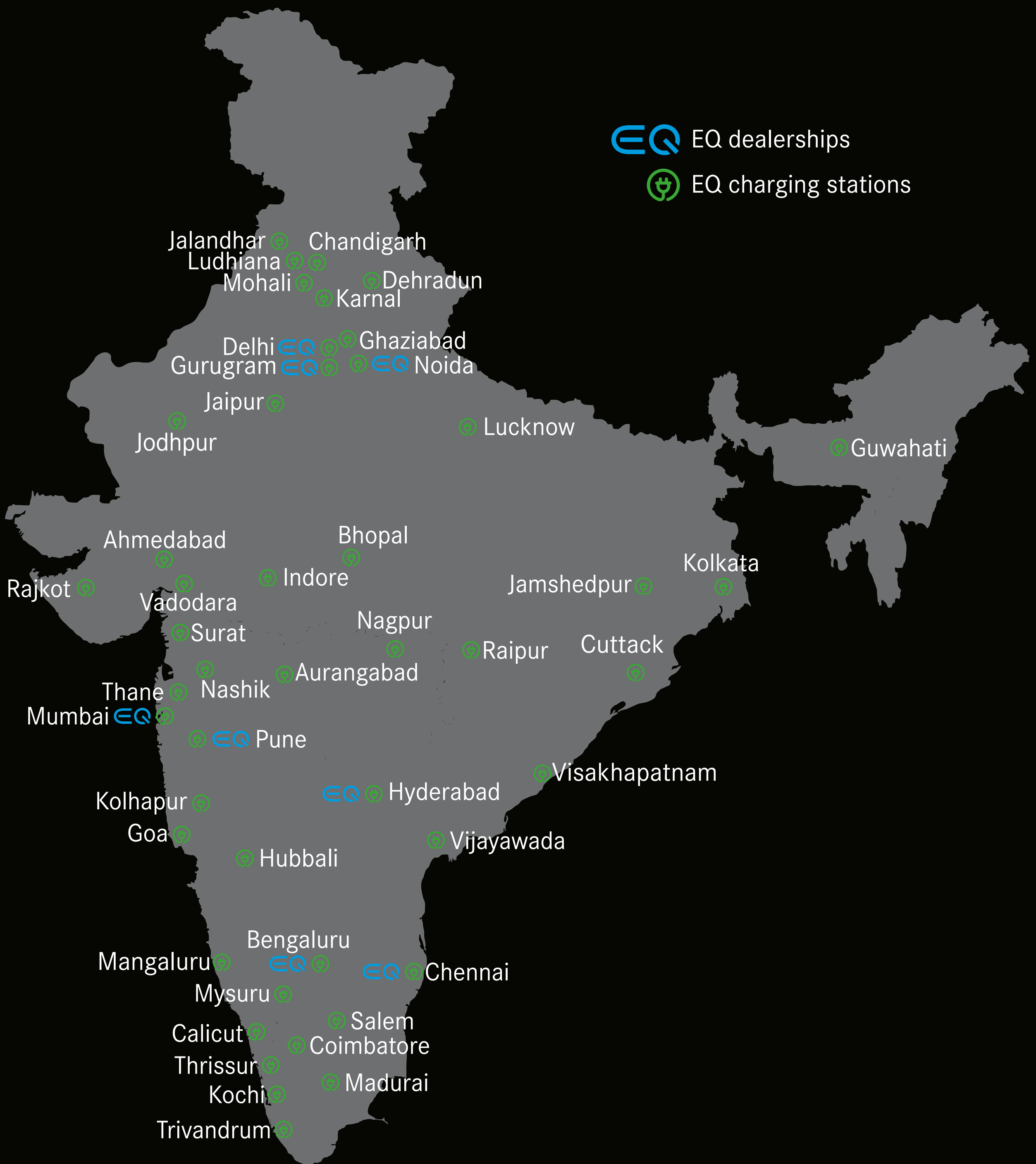

- EQ dealerships
- EQ charging stations

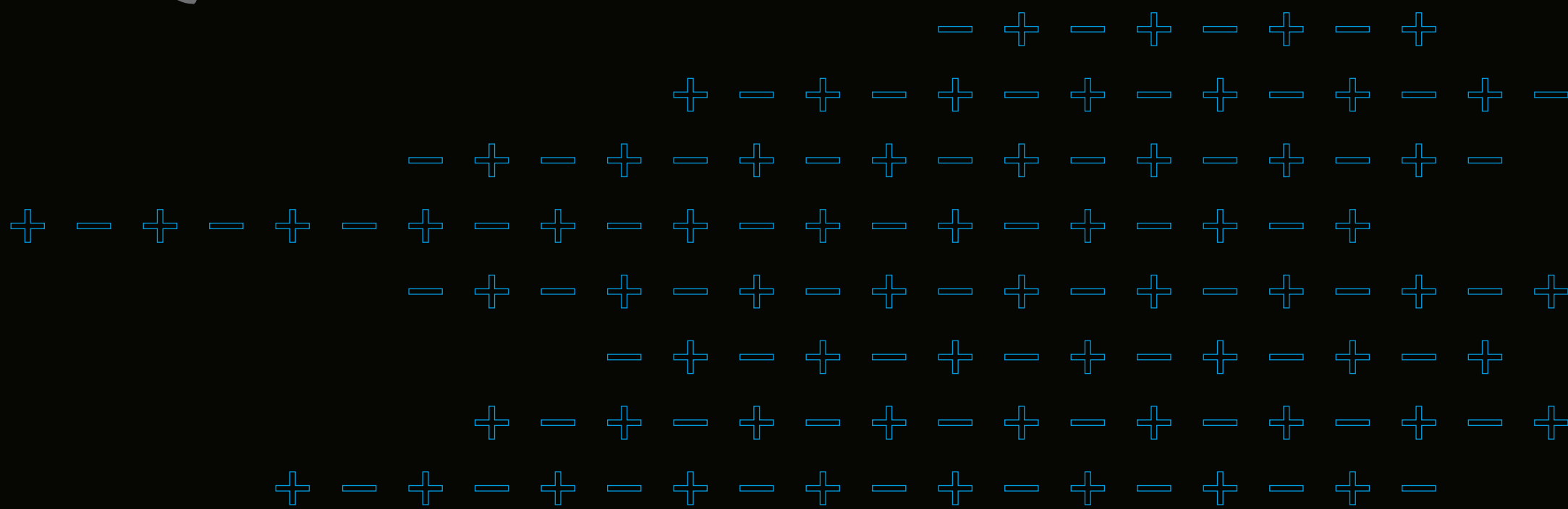

The EQ Ready App

Are you ready for e-mobility? Find out with the new EQ Ready app.

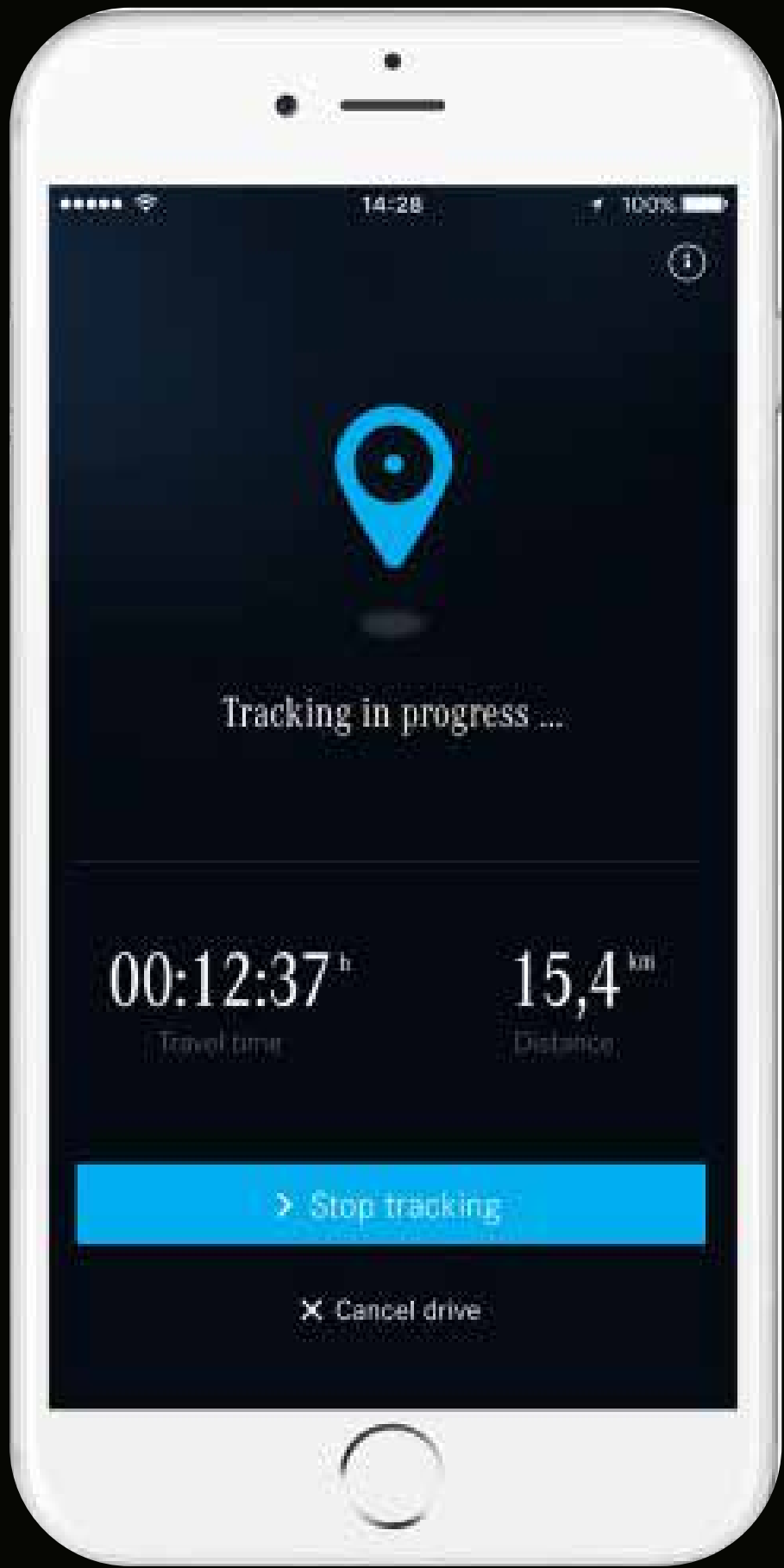
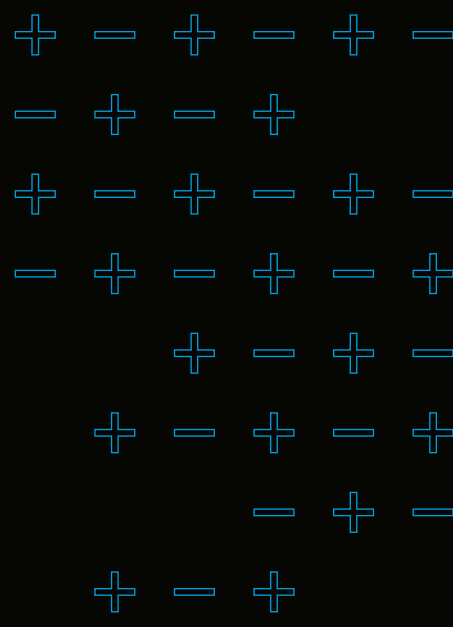

Tracking

- + Check your mobility behaviour and have your trips be evaluated by activating the automatic tracking function.

Trip Overview

- + The app analyses your driving behaviour while measuring environmental parameters such as temperature and elevation profile.

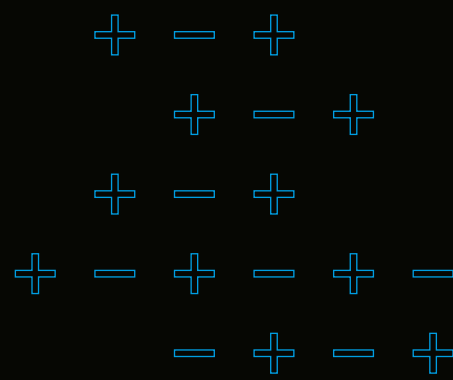

Trip details

- + Generate results based on your specific usage and compare how an EV will reach the same destination using the EQ Ready app.

EQ Predict

- + Calculate routes in advance including the energy demand based on historical traffic data and the individual battery consumption with charging recommendations.

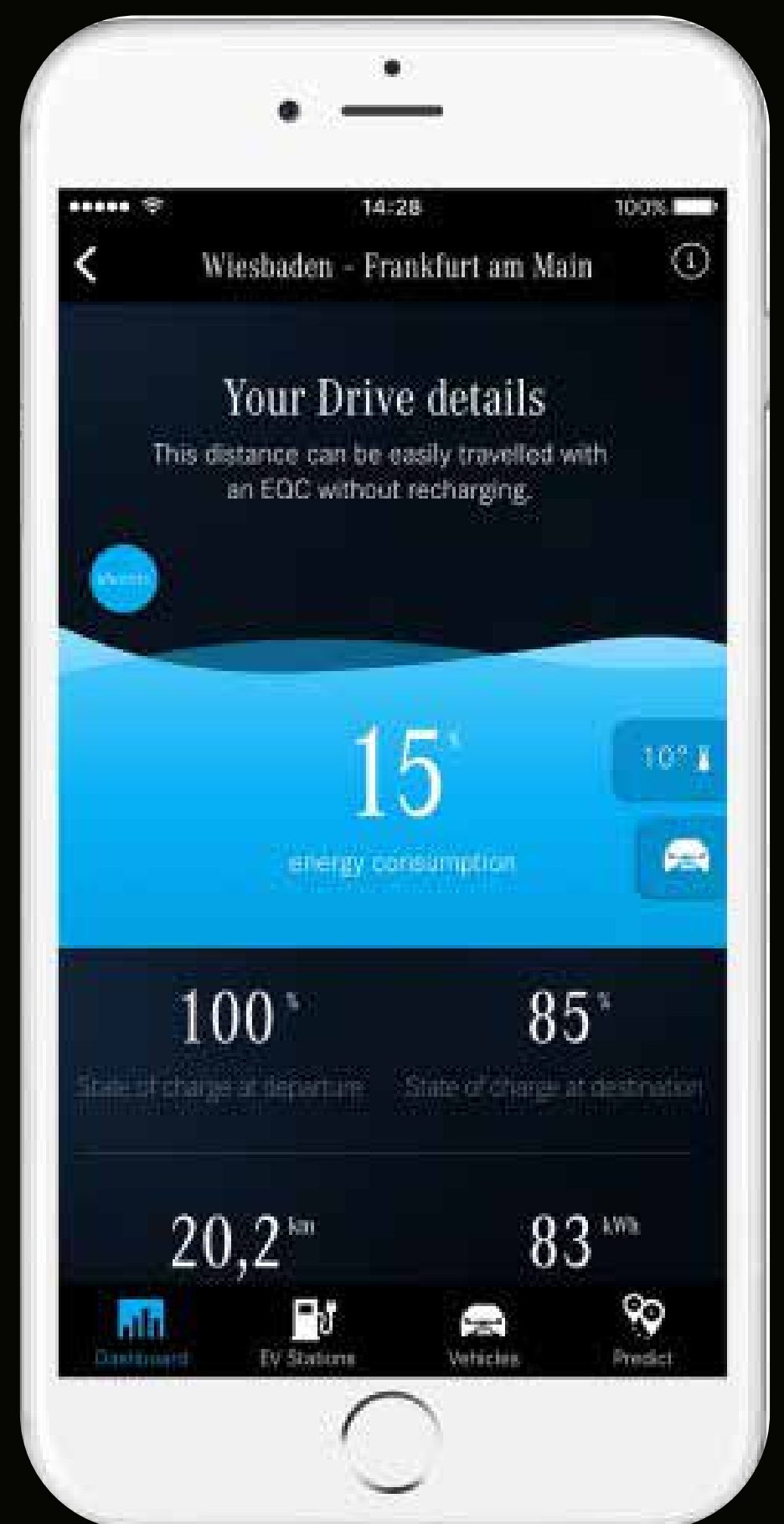
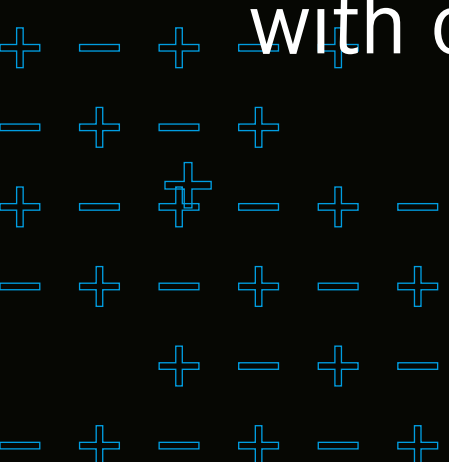

**Please read the disclaimer.*

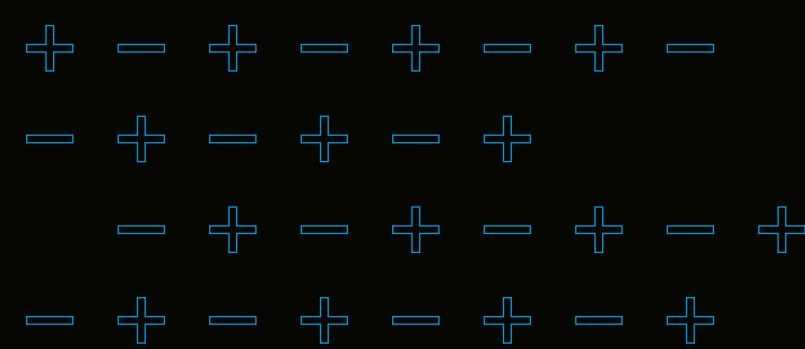
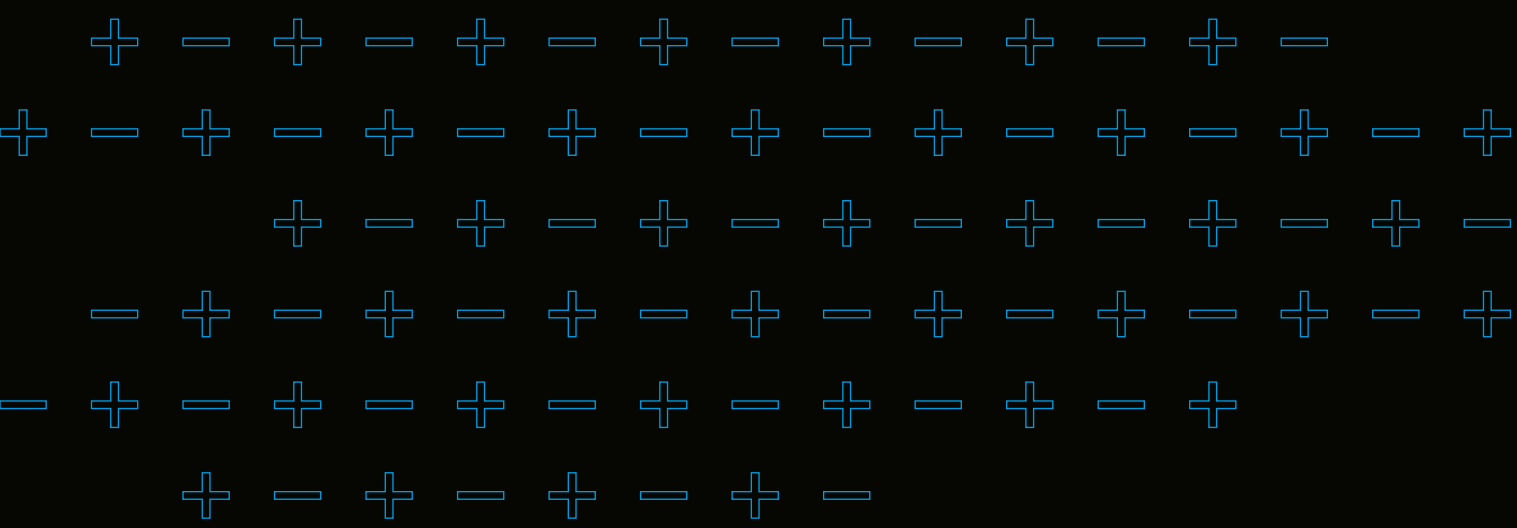

Mercedes-Benz India Private Limited: E-3, MIDC Chakan - Phase III, Chakan Industrial Area, Kuruli & Nighoje, Tal: Khed, Pune - 410 501 (India) Toll free No.: 0008000501888.
e-mail: cs.ind@cac.mercedes-benz.com, **website: www.mercedes-benz.co.in**

Please note: This brochure is intended for general information, description and illustration of the Product including optional functions and equipment and may not be specific to a Product since specification of a product may change from time to time. Optional features, functions and equipment etc. may not be present in the Standard or Variant Product or Special Edition Product. Further, Standard specifications of a product may also vary from time to time. Colours may differ from those shown in pictures in the brochure. Mercedes-Benz India reserves the right to make changes without prior notice, in design, colours, materials, components, equipment, specifications, features, functions, make and models etc. The information given in this brochure shall be regarded as accurate at the time of launch and may vary thereafter due to any developments or any other reason. Interested customers should reach out to the Authorised Dealer for further information on the exact specifications, features of the product.

Images shown are for representation purposes only. Some of the vehicles in the Brochure are left hand drive wheel. However, Mercedes-Benz India only manufactures and sells vehicles as per the applicable motor vehicle regulations in India. All vehicles sold by Mercedes-Benz Authorized Dealers shall be with right hand drive wheels only.

All title, ownership rights and intellectual property rights in and relating to this brochure/magazine or publication material or any copies thereof including but not limited to copyright, logos, names, trademarks, service marks, design, text, images, links, concepts and themes are owned by Daimler AG and/or its subsidiaries collectively or used under authorised license by the Daimler AG. Any reproduction, transmission, publication, performance, broadcast, alteration, license, creation of derivative works or other use in whole or in part in any manner without the prior written consent of Mercedes-Benz India Pvt. Ltd is strictly prohibited.