

# The Mercedes-Benz C-Class. Never Stop Improving.



Mercedes-Benz





## Never stop improving.

It is not about being better than others. It is about getting better than you are. That is what counts. In sport as well as on the road. The C-Class is known for its perfect proportions, its comfort, its quality and its drive: to exceed itself every day, on every journey, over and over again.



## On top form, when it matters.

The sense of forward momentum in the new C-Class is plain to see: the modified front end simply exudes dynamism and contemporary appeal. Depending on the precise specification, it features redesigned bumpers, gleaming chrome trim and stunning new LED headlamps.

\*Please read the disclaimer.



When it all feels perfect,  
there can only be one objective:  
to make it even better.

Perfect training conditions await you in the new C-Class Saloon: the new steering wheel with Touch Control buttons along with, depending on the precise specification and larger displays including a new-generation multimedia system, are state-of-the-art features that make operating the car a highly individual affair.

\*Please read the disclaimer.

## 9G-TRONIC

Let your vehicle take care of changing gears: you will barely notice the gear changes made by the 9G-TRONIC automatic transmission. Nine gears enable low engine speeds, which reduces your fuel consumption and ensures a more pleasant noise level.

When you select the Comfort and ECO drive programs via DYNAMIC SELECT, the 9G-TRONIC shifts through the nine gears for you smoothly and efficiently, thus providing optimum ride comfort. In addition, the transmission is also truly sporty: at the press of a button you can experience fast, sporty gear changes while nevertheless frequently driving in the optimum engine speed range. As such you can enjoy even more driving pleasure in Sport mode as a result of correspondingly better performance.



\*Please read the disclaimer.

## DYNAMIC SELECT

DYNAMIC SELECT changes the handling characteristics at the press of a button. Use different drive programs which change the characteristics of the engine, transmission, suspension and steering. Whether dynamic in Sport mode, highly relaxed in Comfort mode or particularly economical in ECO mode – you determine precisely what is important to you. The ECO drive program supports you when you want to reduce CO2 emissions. The seat heating and air conditioning work with reduced output in this setting and thus save

valuable energy. With Individual mode you can define the parameters precisely to suit your personal preferences. This means that you can select a sporty setting for the drive system and at the same time have a comfortable setting for the chassis.



\*Please read the disclaimer.

## Night Package.

The Night package creates visual attractions: many exterior elements are designed in black. This emphasizes the sporty character and the special individuality of your vehicle. And you demonstrate a sense of expressive design and exclusive sportiness.

The night package adds attractive features in addition to the AVANTGARDE line: many exterior elements are finished in attractive black color.

They underscore the sporty character and special individuality of your vehicle. The Louvres are in high-gloss black and trim in high-gloss chrome. The specific front apron is with high-gloss black trim and high-gloss black painted exterior mirror housings. The beltline trim strip and window weather-strip in high-gloss black.



\*Please read the disclaimer.

## The AVANTGARDE equipment line.

With the AVANTGARDE exterior you can emphasise the individuality of your vehicle – and demonstrate the appeal of contemporary sportiness. The outcome of the interplay between the various design elements is an extraordinarily expressive vehicle. The lowered suspension offers the ideal balance between dynamism, comfort and safety.

The AVANTGARDE interior allows you to show what matters to you: stylish sportiness, characterful individuality and top-class quality. With the Interior Lighting package, the merits of the interior can be seen even more clearly.



\*Please read the disclaimer.



## Exteriors

### Led High Performance Headlights

The LED High Performance headlamps illuminate the road considerably more precisely and generously than conventional halogen or xenon headlamps thanks to state-of-the-art LED technology. Thanks to the high light range traffic situations and obstacles can be seen earlier, thus resulting in increased safety. The uniform warm-white light quality is close to the colour temperature of daylight. This puts less of a strain on your eyes and helps you to concentrate for longer and remain more relaxed.

The LED tail lights shine with their well-conceived function, as their light intensity adjusts automatically to the light conditions. This has two advantages: on the one hand, your vehicle can be clearly seen by other road users in any situation - on the other, it ensures that other road users are not dazzled.

“See and be seen” takes on a new meaning with the LED High Performance headlamps: the exceptional design of both front lights and tail lights is determined by clearly defined contours. High-quality sculpted details create attractive highlights and underscore the cutting-edge, technical aspects. The fact that these headlamps are something very special is seen each time you unlock and lock your vehicle: your vehicle greets you and says goodbye with a brief light display - the headlamps are subtly activated and after a soft transition shine in bright white



\*Please read the disclaimer.

## Exteriors

### **Panoramic sliding sunroof**

The panoramic sliding sunroof creates a genuine open-air ambience. The large area of glass allows interesting views and creates a friendly atmosphere. When driving with the roof open, you will enjoy the feeling of freshness.

The electric panoramic sliding sunroof is opened either continuously or by using the one-touch function. Or you can use the tilt position – the opening gap is then automatically suited to the vehicle speed. This allows you to enjoy fresh air in a pleasant intensity. Whatever the roof's position, wind noises are effectively minimised. On sunny days the electric roller sunblind provides welcome shade when needed.



\*Please read the disclaimer.

# Interiors

## AVANTGARDE interior

With the AVANTGARDE interior you can show what is important to you: stylish sportiness, resolute individuality and first-class quality. The avantgarde highlights and expressive ambience will bring you joy day after day. The interior benefits are clearly visible thanks to the Interior Light package.

## Front Massage Seat package

Your back will enjoy the appreciation it deserves: the individually adjustable lumbar support significantly relieves the strain on the lower back and relaxes the muscles. Even more pleasant, and not just on long journeys, is the additional massage function. The Massage seats come with inflatable air chambers in the lower backrest. Massage effect is in the lumbar region through pulsating air chambers in the lumbar support. The functions are adjustable via the media display.



\*Please read the disclaimer.

# Interiors

## Front Wireless Charging

Driving time becomes charging time – with just a simple hand movement your smartphone can be fixed in place in the oddments tray where it is charged wirelessly. Irrespective of the model and brand, compatible smartphones are charged wirelessly.

## Midline Sound System

The sound system adds listening pleasure to driving enjoyment. The 9 speakers with 225 W amplifier output is precisely configured for the vehicle interior for the dynamic reproduction of music.

## All-digital instrument display

The fully digital instrument display with the display styles “Classic”, “Progressive” and “Sporty” enables you to decide which information is important to you and in which way you wish to have it displayed. The 31.2 cm (12.3-inch) display delivers a pin-sharp image which is very easy to read in all light conditions.



\*Please read the disclaimer.

## Interiors

### Memory Package

Comfortable and individual adjustment of the seating position and head restraint is made possible by the electrically adjustable driver's seat – for pleasant journeys with a healthy posture. The included memory function is particularly useful if different drivers use your vehicle and the seat adjustments are changed frequently.

### Electric roller-blind for rear

The electrically extending and retracting roller sunblind for the rear window protects against direct sunlight in summer and when the sun is low in the sky. As a result, as the driver you can ensure that you are not dazzled by sunlight entering from the rear. In addition, the interior heats up less. Visibility to the rear is maintained.



\*Please read the disclaimer.

## Interiors

### Folding rear seat backrests

The rear bench seat of your vehicle has a 40:20:40 split-folding design. This provides you with maximum flexibility: you can fold down the sections individually, in combination or totally. Thanks to EASY-PACK Quickfold, this can be done quickly and easily by hand. In the boot you will find the comfort controls. With these you can unlock the seats at the press of a button or a light tug on the lever, without first having to remove the head restraints. For additional safety you have at your disposal as standard the load-securing rings on the luggage compartment floor for securing the load.



### Roller sunblinds in left and right rear doors

The manual pull-out roller sunblinds protect against direct, bright sunlight in summer and when the sun is low in the sky. As a result your rear passengers are not dazzled and the interior heats up less. It still remains possible to see out of the rear windows – for a pleasant and eventful journey.



\*Please read the disclaimer.

# Interiors

## 64 color Ambient lighting

Showcase the interior according to your personal preferences or current mood. With a total of 64 colours, the ambient lighting gives you almost unlimited scope for lighting schemes, and has the right colour available for any situation.

## Audio 20 with HD Media Display

Audio 20 GPS provides you with varied entertainment and a comprehensive range of infotainment functions. Connect your smartphone conveniently with your car via Bluetooth and use the perfectly integrated telephony and music functions on a display incorporated elegantly into the interior design and featuring a 10.25-inch screen diagonal. Thanks to the higher resolution of 1920 x 720 pixels you can enjoy brilliant image quality with pin-sharp display of all infotainment content.

## Smartphone integration package

The Smartphone Integration joins the mobile phone with the media system via Apple® CarPlay® and Android Auto®. This gives you convenient access to the most important applications of your smartphone. You can also use apps from third party service providers such as Spotify quickly and easily.



\*Please read the disclaimer.

# Mercedes me connect

Mercedes me connect allows drivers to stay in touch with their vehicles from anywhere in the world, and to obtain assistance at the touch of a button.

Let your personal digital assistant take the experience to an all new level in your everyday life.

- ✓ Stay informed. About your Mercedes-Benz and everything associated with it. Tyre pressure: okay! Fuel tank: nearly full!
- ✓ Off to new places: You can directly send any type of destinations to your vehicle from your smartphone.
- ✓ Relax on the road. Calmly complete your first conference call during your journey as the navigation system plots the ideal route to your next meeting.

All-in-one service package: Get reminders and never miss a service appointment, conveniently book your service appointment online.

Please note that certain services are offered free of cost for a period of three (03) years and may be chargeable at the expiry of three (03) years from the date of activation of such services. If you wish to continue using those services, you may renew the same through Mercedes Me Store (as and when it is available). Please get in touch with your preferred Franchise Partner for more details.



\*Please read the disclaimer.



# Vehicle Monitoring

**Parked Vehicle Locator:** Unfamiliar city, winding streets – where was it you parked? Your smartphone knows the answer. It can locate your parked vehicle within a radius of 1.5 kilometres and show you on a map how to make your way back to the vehicle.

**Vehicle Tracker:** Perhaps a family member is driving your car and you wish to know its current whereabouts. The app knows the answer. For this purpose, your vehicle's geo-coordinates are sent by GPS. The driver receives a message that they are being geolocated. The driver can deactivate the Vehicle Tracker at any time with a free call to the Customer Assistance Center (model-specifically, also via the multimedia system).

**Notification if the vehicle exceeds the set speed:** Receive an alert if your vehicle exceeds a certain speed. The notification is sent directly to your smartphone by an app. This is where you can set the desired threshold value (from 0 to 255 km/h), and obtain a list showing when and where the speed was exceeded. This allows you to stay informed when someone else is using your vehicle.



Please note that certain services are offered free of cost for a period of three (03) years and may be chargeable at the expiry of three (03) years from the date of activation of such services. If you wish to continue using those services, you may renew the same through Mercedes Me Store (as and when it is available). Please get in touch with your preferred Franchise Partner for more details.

## Vehicle Set-Up

**Remote Retrieval of Vehicle Status:** You have easy access at all times to the most important information about your vehicle – available from the Mercedes me App or the Mercedes me Portal. These include mileage, tyre pressure, washer fluid level, fuel tank level and also when the next service is due.

**Remote Door Locking and Unlocking:** We've all done it: no sooner have you left the vehicle than you suddenly can't remember whether or not you locked the doors. With the Mercedes me App or from the Mercedes me Portal, you always have certainty – and can lock the doors later if needs be. And if you ever lock yourself out, if your passengers are already waiting next to the car or if a friend needs to go back and fetch something from inside the vehicle, you can unlock the doors remotely. In this case, you receive a corresponding acknowledgement on your smartphone.

**Speed Alert:** Receive an alert if your vehicle exceeds a certain speed. Notification is sent straight to the Mercedes me App on your smartphone. It tells you when and where the speed was exceeded. You can set the desired threshold (from 0 to 255 km/h). This allows you to stay informed when someone else is using your vehicle.

**Send2Car function:** Smartphone and car, more connected than ever before: found a place of interest or the best restaurant in town? You can easily send the address to your vehicle via an app. You just need to confirm the import and the data will be integrated into your navigation system.



Please note that certain services are offered free of cost for a period of three (03) years and may be chargeable at the expiry of three (03) years from the date of activation of such services. If you wish to continue using those services, you may renew the same through Mercedes Me Store (as and when it is available). Please get in touch with your preferred Franchise Partner for more details.

### Navigation Connectivity package

In combination with the standard-fit communication module (LTE) and the hard-disc navigation makes sure that you always reach your destination as quickly as possible by the best route. Enhanced Navigation Services can even provide you with predictive information: You are provided with optimised travel destinations and your vehicle can answer questions about your journey, such as current filling petrol station prices along the route or the parking situation at your destination.

### Mercedes-Benz emergency call system

The Mercedes-Benz emergency call system can save you vital minutes in an emergency. If an accident is detected, a communications module with its own SIM card automatically triggers an emergency call which can shorten the time until the rescue services arrive. In the case of a connection with the Mercedes-Benz emergency call centre, a member of staff will support you over the voice connection until the rescue services arrive. This means that you are not left on your own in a stressful situation. Alternatively, an emergency call can be triggered manually to organise assistance.



Please note that certain services are offered free of cost for a period of three (03) years and may be chargeable at the expiry of three (03) years from the date of activation of such services. If you wish to continue using those services, you may renew the same through Mercedes Me Store (as and when it is available). Please get in touch with your preferred Franchise Partner for more details.

\*Please read the disclaimer.

## New Mercedes me connect features

**Alexa Home Integration with Mercedes me connect:** Conversations with Alexa are now more fun when the systems connect with your Mercedes Benz via cloud and give you real time updates. This feature can be used from an Alexa Echo device setup at home, office or also from phone's Alexa App. The command starts with "Alexa, Ask Mercedes to..." or directly initiate a command by saying "Alexa, tell Mercedes to <command>".

**Google Home integration with Mercedes me connect:** Google Home integration is also offered for Google home users. In a similar way, once the Mercedes me connect is linked to Google Home, you can start issuing commands.

**Parking location POIs (Points of Interest):** The introduction of new Parking solution, shows Parking lots available across different parts of the cities. The Parking POIs (Points of interest) can be seen easily on the navigation system or alternatively also on the Mercedes me App maps section.

**Remote window/sunroof open and close:** Allows the automatic window close and open remotely. Also allows to remotely access and open and close the sunroof and keep your car protected.

**Geo-fencing, remote vehicle finder:** It denotes a specific area and notifies via push message when the vehicle leaves or enters a predefined area. The Remote Vehicle Finder indicators activated via the app help to draw attention to the vehicle, for example in large, confusing car parks.

Please note that certain services are offered free of cost for a period of three (03) years and may be chargeable at the expiry of three (03) years from the date of activation of such services. If you wish to continue using those services, you may renew the same through Mercedes Me Store (as and when it is available). Please get in touch with your preferred Franchise Partner for more details.



## Safety and assistance systems

### PRE SAFE System

The PRE-SAFE® system makes use of the time prior to an impending accident on your behalf. A host of measures are able to reduce the loads generated as a result. The innovative PRE-SAFE® Sound generates a noise from the speakers which is able to trigger a natural protective reflex: This protects the inner ear by damping the accident noise.

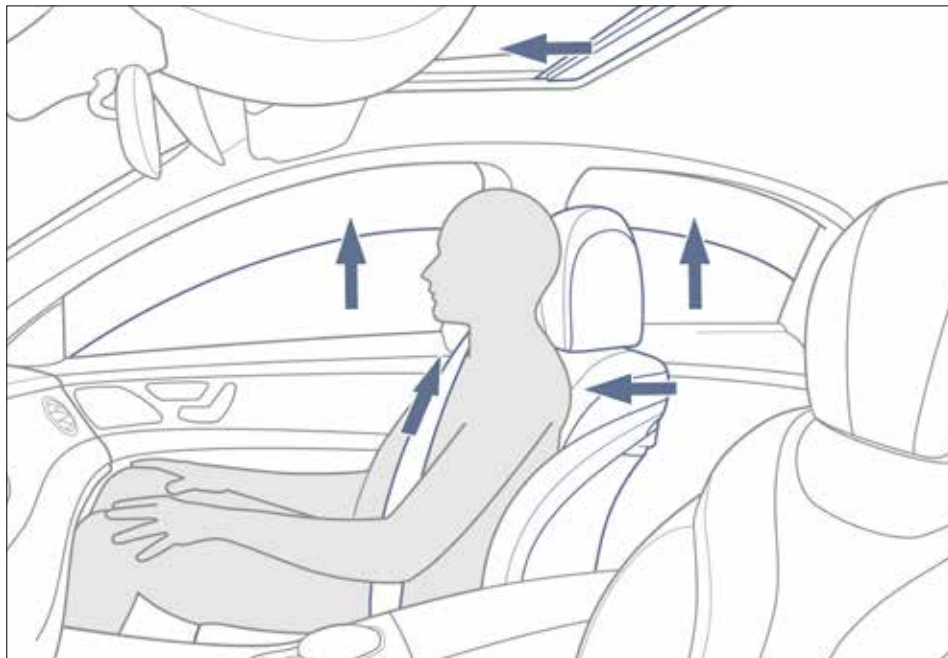

### Cruise Control

The cruise control maintains the speed for you. So that the set speed is not exceeded, it brakes automatically. On long, steep downhill gradients, you must shift down to a lower gear in good time. This should be observed in particular when the vehicle is carrying a heavy load and when driving with a trailer. This way you make use of the braking effect of the engine. As such, you take the strain off the braking system and prevent unnecessary wear and as well as overheating of the brakes.



\*Please read the disclaimer.

## Safety and assistance systems

### Active Parking Assist with PARKTRONIC

Turn the stress of tight parking spaces into effortless calm. Active Parking Assist is not only able to find suitable parking spaces – it also helps you to enter and leave them. It even assists you in steering and accelerating. The PARKTRONIC also monitors the surroundings when manoeuvring, such as in multi-story car parks. In so doing the system issues visual and acoustic warnings about obstructions – you can avoid these and thus also annoying and expensive damage.

### Parking package with reversing camera

With this package you can even master tight parking spaces effortlessly. Convenient: Active Parking Assist searches for a suitable parking space and then helps you to park in it. Peace of mind is the motto for the reversing camera, with which expensive body damage can be avoided thanks to the good overview to the rear.

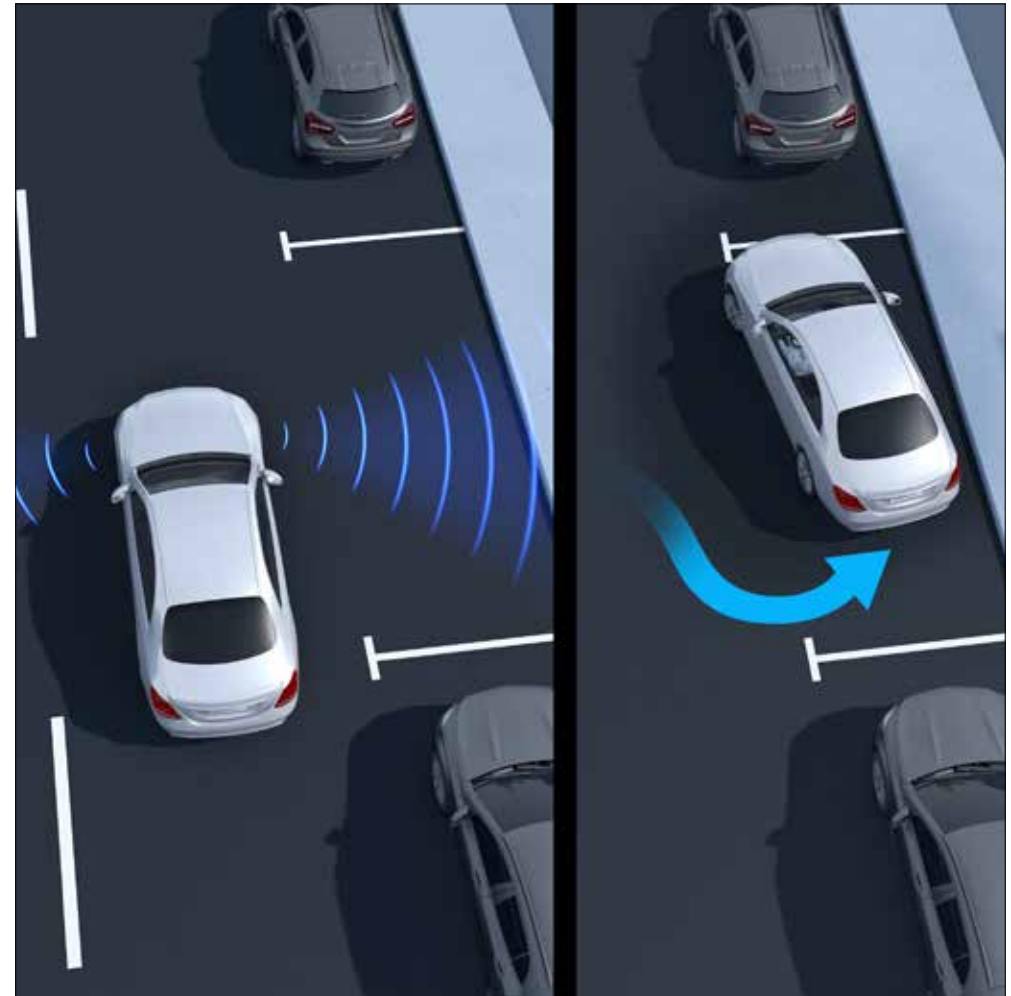

## Safety and assistance systems

### Pedestrian Protection with Active Bonnet

The systems of active safety can help to prevent an accident with a pedestrian or reduce its severity by providing support with braking or evasive manoeuvres. If a front impact with a pedestrian should occur, however, various measures can contribute to reducing the consequences of the accident. For example, the front end of the vehicle is therefore designed to be able to absorb more energy. In specific speed ranges, the active bonnet can additionally be raised. The raising is carried out pyrotechnically in the rear hinge area and increases the distance between the bonnet and the major assemblies in the engine compartment, whereby additional deformation space is created and the risk of injury to pedestrians in specific accident scenarios reduced.

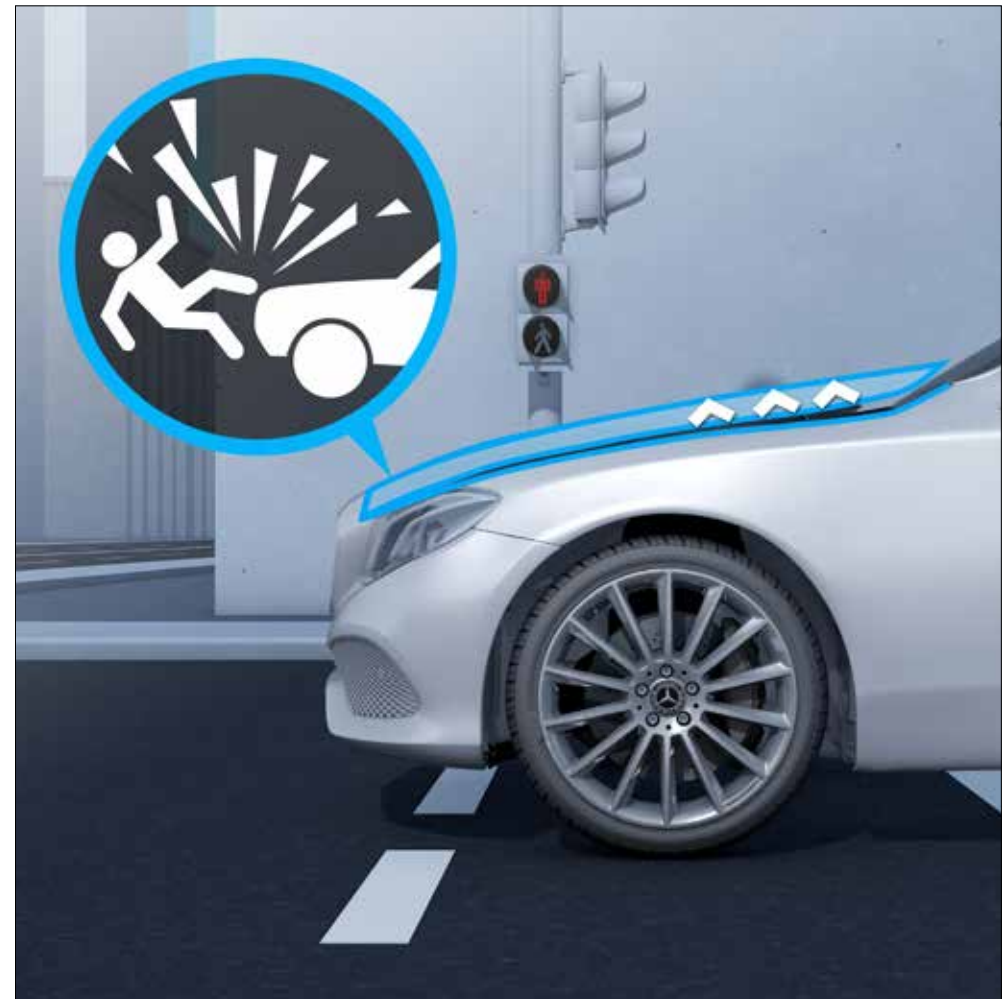

\*Please read the disclaimer.

## Upholstery and trim.

---

### Upholstery

---

ARTICO man-made leather - black

---

ARTICO man-made leather - silk beige / black

---



---

### Trim

---

Brown open-pore walnut wood trim

---





## Paintwork and alloys.

---

### Non- Metallic Paints

---

Polar White

Mojave Silver

Obsidian Black

---

---

### Metallic Paints

---

Selenite grey

Cavansite Blue

Designo Hyacinth Red

---

---

### Alloys

---

43.2 cm (17-inch) 5-twin-spoke light-alloy wheels painted in black with a high-sheen finish

---



## Technical data.

Technical Specification	C200	C220d
Displacement/ No. of cylinders	1991 cc/L4	1950 cc/L4
Rated output (kW [hp] at rpm)	150 [203] @ 5800 - 6100	143 [194]/3800
Transmission	Automatic	Automatic
Acceleration 0-100 km/h (sec.)	7.7 secs	6.9 secs
Top speed (km/h)	239 km/h	240 km/h
Fuel	Petrol	Diesel
Gross vehicle weight	2125 kg	2165 kg
L x W x H (in mm)	4686 x 1810 x 1442	4686 x 1810 x 1442

# Dimensions.

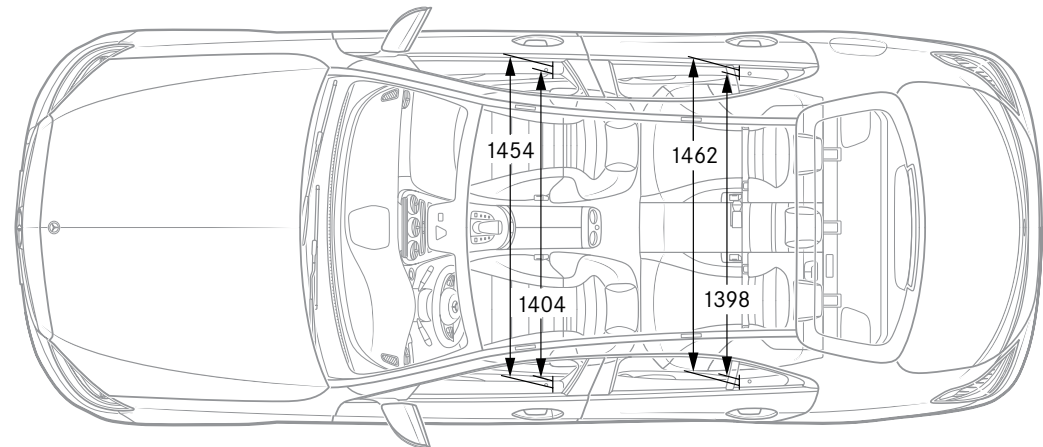
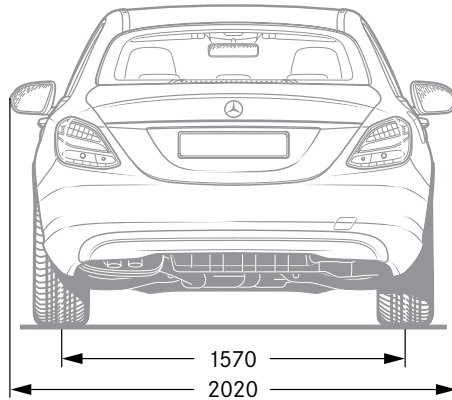
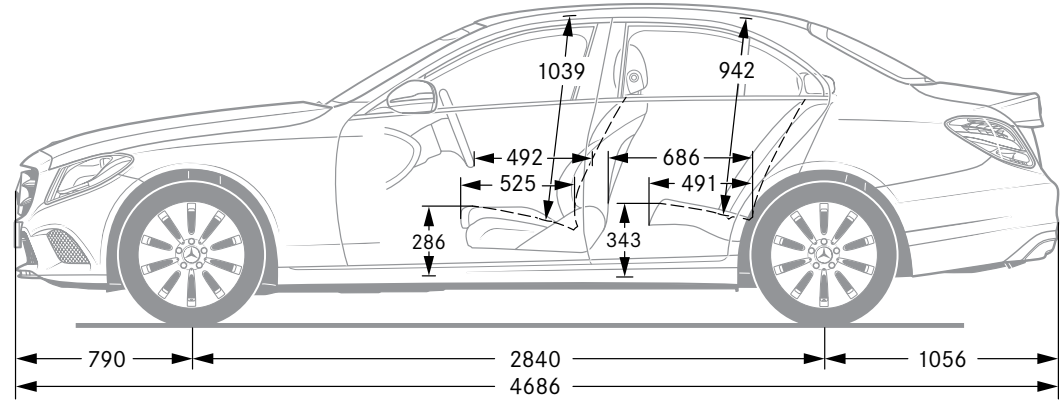
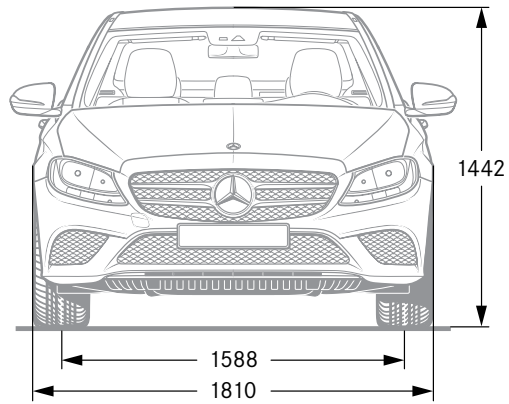

All figures in millimetres. The illustrated dimensions are mean values. They are valid for vehicles in basic specification and in unladen condition.

\*Please read the disclaimer.

**Mercedes-Benz India Private Limited:** E-3, MIDC Chakan - Phase III, Chakan Industrial Area, Kuruli & Nighoje, Tal: Khed, Pune - 410 501 (India) Toll free No.: 0008000501888. e-mail: cs.ind@cac.mercedes-benz.com, **website: [www.mercedes-benz.co.in](http://www.mercedes-benz.co.in)**

**Please note:** This brochure is intended for general information, description and illustration of the Product including optional functions and equipment and may not be specific to a Product since specification of a product may change from time to time. Optional features, functions and equipment etc. may not be present in the Standard or Variant Product or Special Edition Product. Further, Standard specifications of a product may also vary from time to time. Colours may differ from those shown in pictures in the brochure. Mercedes-Benz India reserves the right to make changes without prior notice, in design, colours, materials, components, equipment, specifications, features, functions, make and models etc. The information given in this brochure shall be regarded as accurate at the time of launch and may vary thereafter due to any developments or any other reason. Interested customers should reach out to the Authorised Franchise Partner for further information on the exact specifications, features of the product.

Images shown are for representation purposes only. Some of the vehicles in the Brochure are left hand drive wheel. However, Mercedes-Benz India only manufactures and sells vehicles as per the applicable motor vehicle regulations in India. All vehicles sold by Mercedes-Benz Authorized Franchise Partners shall be with right hand drive wheels only.

All title, ownership rights and intellectual property rights in and relating to this brochure/magazine or publication material or any copies thereof including but not limited to copyright, logos, names, trademarks, service marks, design, text, images, links, concepts and themes are owned by Mercedes-Benz Group AG and/or its subsidiaries collectively or used under authorised license by the Mercedes-Benz Group AG. Any reproduction, transmission, publication, performance, broadcast, alteration, license, creation of derivative works or other use in whole or in part in any manner without the prior written consent of Mercedes-Benz India Pvt. Ltd is strictly prohibited.

Please note that certain services are offered free of cost for a period of three (03) years and may be chargeable at the expiry of three (03) years from the date of activation of such services. If you wish to continue using those services, you may renew the same through Mercedes Me Store (as and when it is available). Please get in touch with your preferred Franchise Partner for more details.

Mercedes-Benz cars: The C-Class meets Bharat Stage VI equivalent emission norms.

CIN - U34102PN1994PTC083160