



MERCEDES - BENZ

GLS

—
The Mercedes-Benz GLS

—
GREATNESS ARRIVES IN A GLS.

MERCEDES - BENZ



GLS

HIGHLIGHTS

THE HIGHLIGHTS OF THE NEW GLS.

MERCEDES-BENZ



BURMESTER® HIGH-END 3D SURROUND SOUND SYSTEM

Enjoy your first-class listening experience with the exquisite Burmester® surround sound system with 29 high-performance speakers



AMG LINE INTERIOR

The interior of the GLS combines great comfort with the character of an off-road car.

GLS



SUV OFF-ROAD CAPABILITIES

The sporty SUV features a fully variable all-wheel drive with off-road driving mode, off-road cockpit and a transparent bonnet.



AIRMATIC®

Air suspension with adaptive damping system and automatic or needs-based regulation of the vehicle level.



AMG LINE EXTERIOR

Impressive presence meets modern design: the GLS combines SUV elements with pure elegance.



EXTERIOR DESIGN

TOWARDS WIDER HORIZONS.

The AMG Line elevates the GLS with sporty elegance, sculpted contours, and performance inspired details. From the multifunction sports steering wheel in nappa leather to the AMG sports pedals, every element enhances its athletic and expressive character, reflecting Mercedes-Benz craftsmanship at every turn. AMG-specific front and rear aprons, side skirts, and wing extensions - all painted in the vehicle color create a cohesive, performance-focused appearance. Larger front brake discs and 21-inch AMG light-alloy wheels underscore its dynamic stance, blending visual sportiness with assured driving confidence.



NIGHT PACKAGE

(GLS AMG LINE)

The Night Package enhances the expressive design of the GLS with high-gloss black exterior elements. Accents on the radiator grille, exterior mirror housings, shoulder line and window line trim strips, along with 21-inch AMG light-alloy wheels, add striking contrasts that underline the vehicle's sporty and modern presence.

MULTIBEAM LED HEADLAMPS

MULTIBEAM LED headlamps adapt intelligently to varying driving and traffic conditions, providing optimal illumination at all times. Multiple light functions support city, country road, motorway, cornering and adverse weather driving, while the adaptive high beam assistant precisely controls individual LEDs to avoid dazzling other road users. An ultra-wide light distribution improves visibility during cornering and off-road driving, complemented by a distinctive light animation when locking or unlocking the vehicle.



CHROME GRILLS

Give your vehicle a bold, extraordinary appeal with striking black design elements that create powerful visual contrasts. High-gloss black accents enhance the exterior, while dark chrome and AMG detailing elevate its sporty sophistication.



TAIL LAMPS

The LED tail lamps underscore the commanding presence of the GLS with a refined, horizontal light signature. Precisely sculpted and seamlessly integrated into the rear design, they emphasise the vehicle's width while creating a distinctive appearance — especially after dark.



PAINTWORK

**SELENITE
GREY**



**OBSIDIAN
BLACK**



**HIGH-TECH
SILVER**



**POLAR
WHITE**



**SODALITE
BLUE**



MERCEDES - BENZ

GLS

ALLOYS



MERCEDES - BENZ

GLS

53.3 cm (21-inch) AMG 5-twin-spoke light-alloy wheels
53.3 cm (21-inch) AMG 5-twin-spoke light-alloy wheels,
aerodynamically optimized, painted high-gloss black with a high-sheen finish.

INTERIOR

SPACE FOR EVERY STORY.

INTERIOR CHROME PACKAGE

Selected silver chrome elements add refined accents throughout the cabin, subtly enhancing its premium character. Chrome-finished controls and trim details on the doors, centre console, climate control panel and EASY-ENTRY switch elevate everyday touchpoints while maintaining a clean and elegant interior aesthetic.

WIDESCREEN COCKPIT

The Widescreen Cockpit combines elegant design with a fully digital interface, allowing information to be presented clearly and intuitively. Multiple display styles - Classic, Sport, Progressive and Subtle can be selected to suit individual preferences, with layouts and content configurable via touch controls. Display themes can also be coordinated with ambient lighting for a cohesive and personalized cockpit experience.

MULTIFUNCTION SPORTS STEERING WHEEL IN NAPPA LEATHER

The multifunction sports steering wheel is upholstered in soft Nappa leather and features a flattened bottom section for a sportier feel. Ergonomically contoured for a secure grip, it integrates touch control panels that allow key vehicle functions to be operated conveniently without taking your hands off the wheel.

THERMOTRONIC AUTOMATIC CLIMATE CONTROL

THERMOTRONIC automatic climate control with **five climate zones** allows the driver, front passenger and rear occupants to adjust temperature and air distribution independently. Individual settings can be saved and recalled at the touch of a button, ensuring a consistently comfortable interior climate for every journey.

PANAROMIC SLIDING SUNROOF

The panoramic sliding sunroof creates a bright and open atmosphere within the cabin, enhancing the sense of spaciousness for all occupants. An electric sun blind, anti-pinch protection and PRE-SAFE® locking function ensure comfort and safety, while the expansive glass surface adds to the GLS's exclusive exterior appearance.

ENERGIZING AIR CONTROL

ENERGIZING AIR CONTROL continuously monitors air quality using fine dust and air quality sensors. A two-stage filter system reduces fine dust and most inhalable pollutants, while the system intelligently switches between fresh air and recirculated air modes to maintain a pleasant and healthy cabin environment.

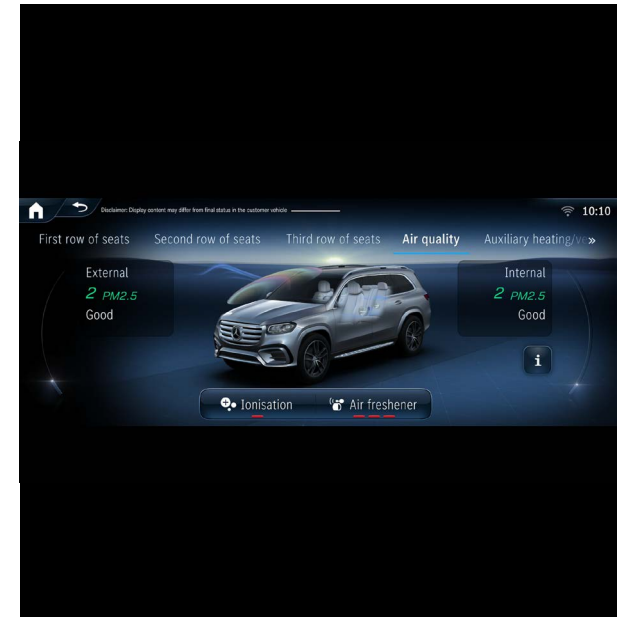



BURMESTER® 3D SURROUND SOUND SYSTEM WITH DOLBY ATMOS

The Burmester® surround sound system delivers exceptional audio experience through 13 high performance speakers and 590 watts of system power. Integrated Dolby Atmos® technology creates an immersive, three-dimensional soundstage, ensuring outstanding clarity and depth across all frequencies.

Sound Personalization further enhances the listening experience by tailoring the system to individual preferences. A digital setup assistant analyses listening habits and stores personalized sound settings within a user profile, while advanced noise compensation dynamically adapts audio output to driving conditions, always ensuring consistent sound quality.

MEMORY PACKAGE WITH SEAT KINEMATICS

The Memory Package enables storage and recall of individual seats, steering column and mirror settings, ensuring personalized comfort for multiple drivers. ENERGIZING seat kinematics support posture on long journeys, while 4-way lumbar support allows precise adjustment of the seat's backrest contour.

Front seats also feature 3-stage seat heating and ventilation, enabling occupants to maintain an ideal seating climate regardless of external conditions. PRE-SAFE® functionality adjusts the front passenger seat position in critical driving situations to enhance occupant protection.



5+2 SEATING CONFIGURATION

The GLS offers a flexible 5+2 seating layout, providing accommodation for up to seven occupants. Two full-size seats in the third row ensure a high level of comfort, while the EASY-ENTRY system allows convenient access. Seats can be folded as required to create additional luggage space when needed.

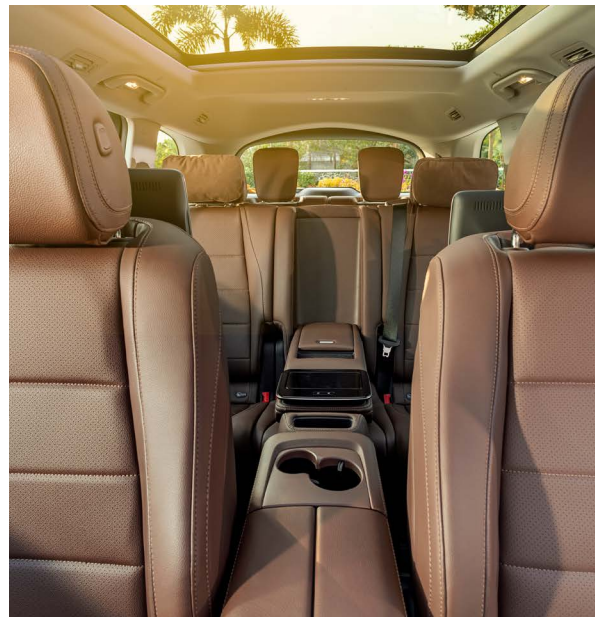

REAR COMFORT & CHAUFFEUR PACKAGE

This package elevates the rear-seat experience with features designed for relaxed and spacious travel. Extra-soft comfort headrests with individual adjustment options provide enhanced support for the head, neck and shoulders, while padded armrests and an extended centre armrest add to long-journey comfort.

The Chauffeur function allows the front passenger seat to be electrically adjusted from the rear at the touch of a button, creating a noticeably larger footwell. An extended centre console with storage compartments, cup holders and USB charging ports ensure convenience and functionality for rear passengers throughout the journey.

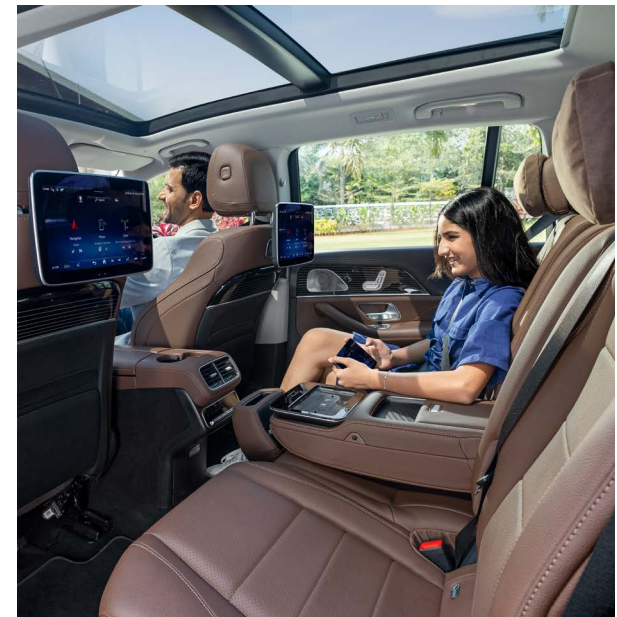

EASY-PACK TAILGATE & CARGO AREA COVER

The EASY-PACK tailgate allows the luggage compartment to be opened and closed electrically at the touch of a button, with a storable opening height for added convenience. The rear of the vehicle can also be lowered to simplify loading and unloading of heavy or bulky items.

The removable EASY-PACK cargo area cover protects luggage from sunlight and prying eyes. When not in use, it can be conveniently stored in the dedicated compartment beneath the cargo floor.



ACOUSTIC COMFORT PACKAGE

The sound insulation of the Acoustic Comfort package significantly reduces disruptive exterior noise. Together with additional insulation measures, the laminated glass with acoustic film effectively reduces ambient noise. So you can enjoy a quiet travel ambience even at high speeds.

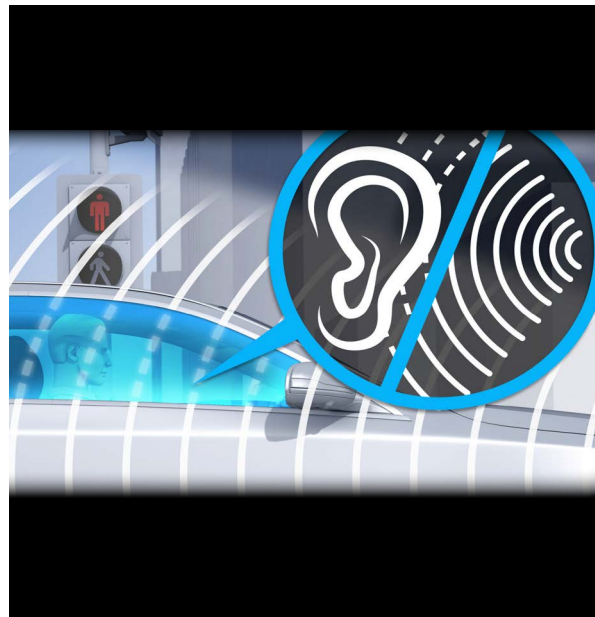

AMG FLOOR MATS (GLS AMG LINE)

AMG floor mats with distinctive "AMG" lettering complement the sporty interior character of the GLS AMG Line while protecting the footwell. They can be easily removed and cleaned as required.

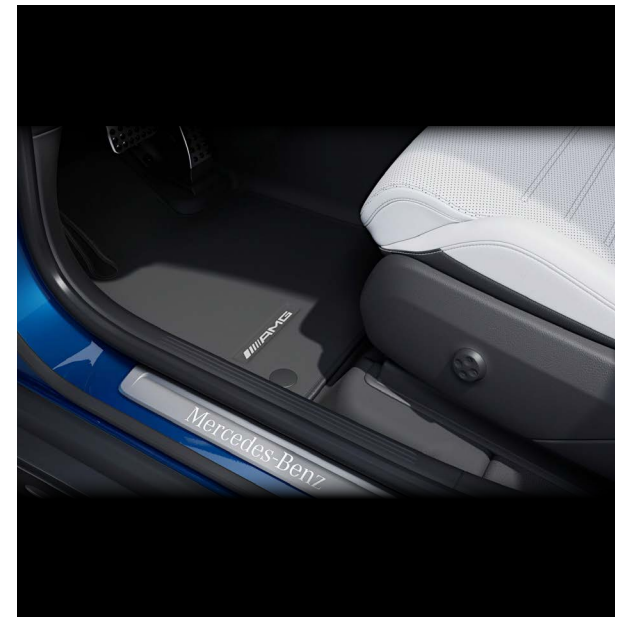

UPHOLSTERY

MERCEDES - BENZ

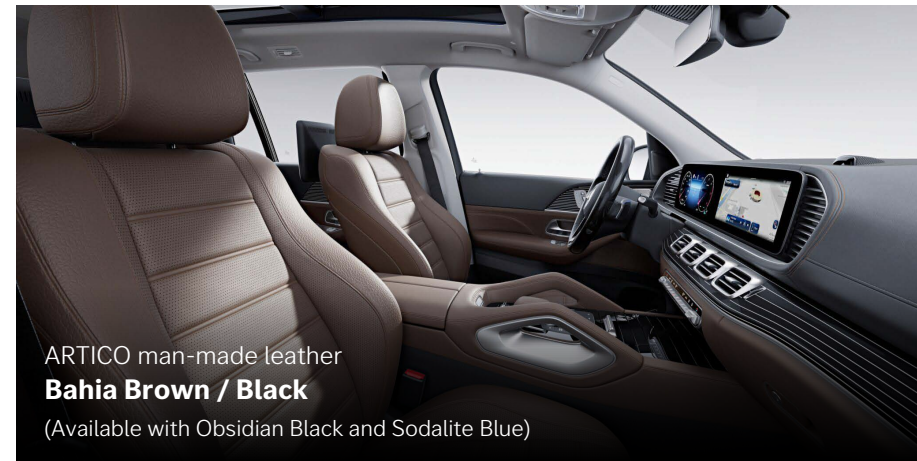
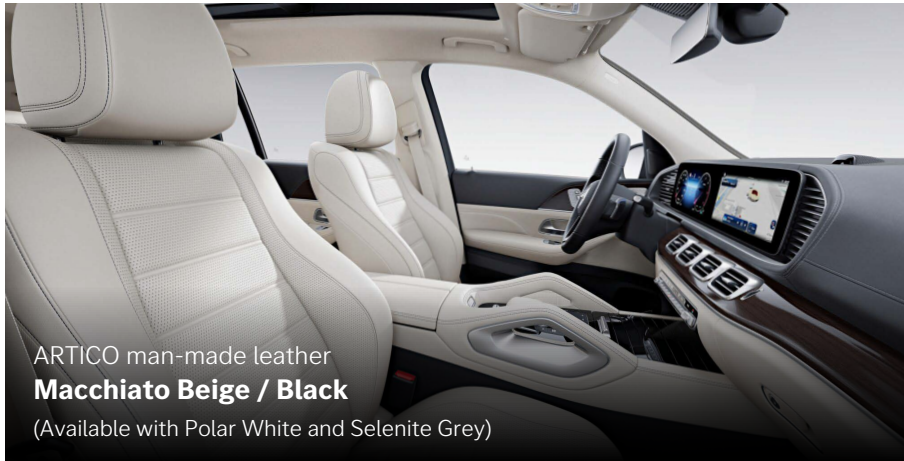

GLS



PERFORMANCE & HANDLING

POWER YOU CAN TRUST.

500

Nm

6.1s

0-100 km/h

280

kW



POWERFUL AND REFINED DRIVING EXPERIENCE

The GLS combines effortless performance with refined comfort, delivering confident acceleration, smooth power delivery and assured handling across long journeys and varied driving conditions. Advanced engine technologies and intelligent chassis systems work seamlessly to ensure a driving experience that feels powerful yet composed at all times.

GLS 450 4MATIC - PETROL ENGINE

The inline M256M 6-cylinder petrol engine offers strong performance with exceptional smoothness. Supported by a mild hybrid system with integrated starter generator (ISG), it delivers additional boost when required while improving efficiency and responsiveness.

An additional electric compressor ensures immediate torque at low engine speeds, eliminating turbo lag.

Twin-scroll turbocharger with air-water intercooling enhances responsiveness.

NANOSLIDE® cylinder liners, inspired by Formula 1 technology, reduce friction and increase durability.

Lightweight aluminium crankcase and cylinder head improve heat dissipation and long-term engine stability.



GLS 450 D 4MATIC - DIESEL ENGINE

The inline OM656M 6-cylinder diesel engine delivers powerful performance with impressive efficiency and refinement. The second-generation mild hybrid system (ISG) supplies additional power and torque, enhancing responsiveness while maintaining fuel efficiency.

Two-stage turbocharging with variable turbine geometry ensures strong low-end response. Twin-scroll turbocharger with air-water intercooling enhances responsiveness.

NANOSLIDE® cylinder liners reduce friction and improve durability. High-pressure common rail injection (up to 2,700 bar) ensures precise fuel delivery for smooth, quiet combustion and reduced emissions.

Aluminium crankcase and cylinder head reduce engine weight, improving handling and front-axle load balance.



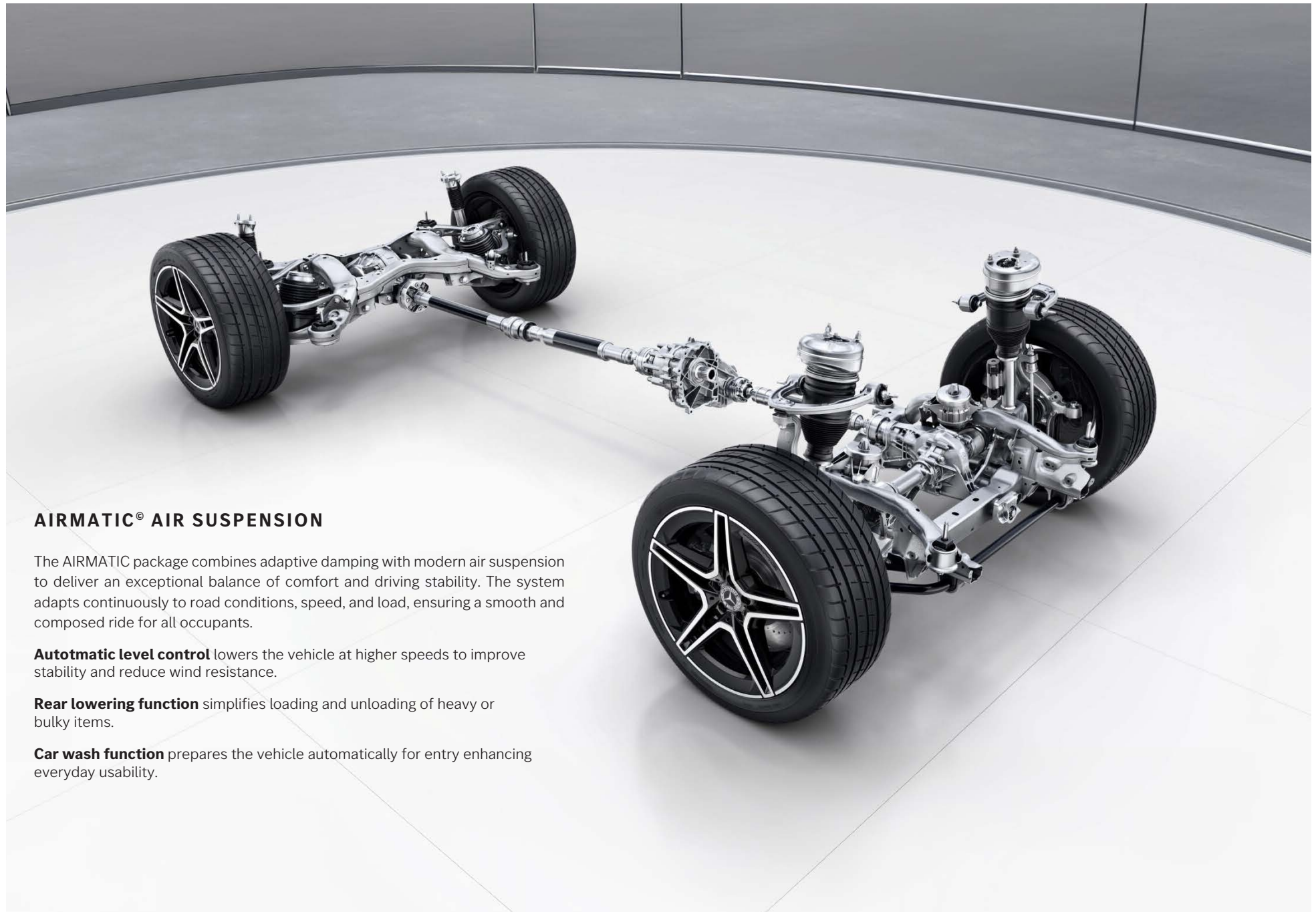

AIRMATIC® AIR SUSPENSION

The AIRMATIC package combines adaptive damping with modern air suspension to deliver an exceptional balance of comfort and driving stability. The system adapts continuously to road conditions, speed, and load, ensuring a smooth and composed ride for all occupants.

Automatic level control lowers the vehicle at higher speeds to improve stability and reduce wind resistance.

Rear lowering function simplifies loading and unloading of heavy or bulky items.

Car wash function prepares the vehicle automatically for entry enhancing everyday usability.

OFF ROAD ATTRIBUTES

Max. angle of approach/departure	27/24° degrees
Breakover angle at perm. GVW	15° degrees
Maximum tilt angle	35° degrees
Max. fording depth	500 mm
Slope climbing ability	100 %



TECHNOLOGY & CONNECTIVITY

INTUITIVE BY DESIGN.

MBUX MULTIMEDIA SYSTEM

The MBUX system transforms the way you interact with your GLS. Adaptive voice assistant, learning capabilities, and personal profiles make it intuitive, responsive and fully personalized. Voice control understands natural speech, even indirect commands, and can adjust vehicle functions like air conditioning. Learning assistant adapts to your speech patterns and language, improving recognition over time. Personal profiles & prediction functions allow saving preferred settings for driving modes, radio stations, ambient lighting and even frequently called contacts, turning your vehicle into a smart, personalized assistant.

MBUX REAR SEAT ENTERTAINMENT

Rear passengers enjoy a fully connected and interactive experience with high-resolution touchscreens and a 7.4-inch wireless MBUX rear tablet. Control multimedia playback, comfort features, ambient lighting, and temperature remotely. The system supports HDMI, Bluetooth, and interactive display sharing, allowing content to be moved seamlessly between screens. Voice and touch input are fully integrated, including seat specific "Hey

MBUX ENTERTAINMENT & STREAMING

Integrated music streaming and internet radio provide seamless access to your favorite services such as Amazon Music, Apple Music, and Spotify, as well as TuneIn internet radio. Access playlists, podcasts, and data packages directly from the vehicle, ensuring entertainment on the move.

KEYLESS-GO COMFORT PACKAGE

Enjoy effortless access with KEYLESS-GO and HANDS-FREE ACCESS. Start and lock your GLS simply by carrying your key, and open or close the tailgate fully automatically, without touching the vehicle. Convenience and security are seamlessly combined.



HARD-DISC NAVIGATION

The navigation system uses a combination of local and online information to guide you efficiently to your destination.

- **2D and 3D map views** clearly display upcoming maneuvers.
- **Route predictions** include fastest and non-toll options.
- **Flexible input** via touchscreen, steering wheel controls, or MBUX voice assistant ensures simple operation using everyday language.
- **Online connectivity** automatically updates map data via the mobile network.

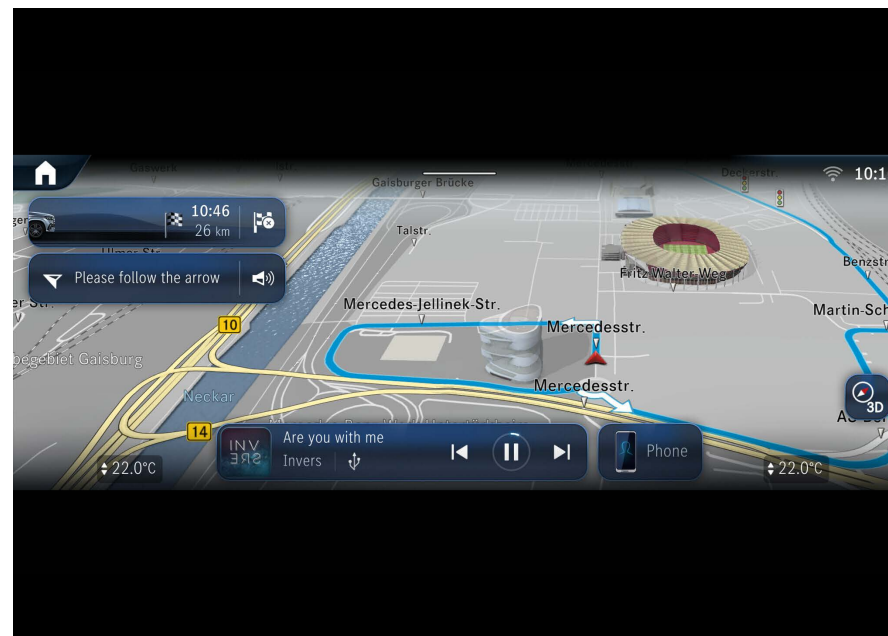

SAFETY & DRIVER ASSISTANCE

PROTECTION, SEAMLESSLY INTEGRATED.

OFF-ROAD SAFETY FEATURES

Transparent Bonnet: Virtually see the area directly in front of the vehicle on rough terrain, enabling confident maneuvering and obstacle avoidance.

Underbody Protection: Shields the vehicle's undercarriage and engine compartment from damage and contamination during off-road driving.

COMPREHENSIVE AIRBAG PROTECTION

Knee Airbag: Protects legs during a serious frontal collision, working in tandem with the seatbelt and restraint system.

Rear Sidebags: Safeguard the chest area of outer rear passengers in side-impact situations, complementing standard window airbags to reduce injury severity.

ADAPTIVE HIGHBEAM ASSIST PLUS

Drive confidently at night without dazzling other road users. The intelligent LED system automatically adjusts the high beam around oncoming traffic and vehicles ahead, providing maximum illumination for better visibility and safer driving.

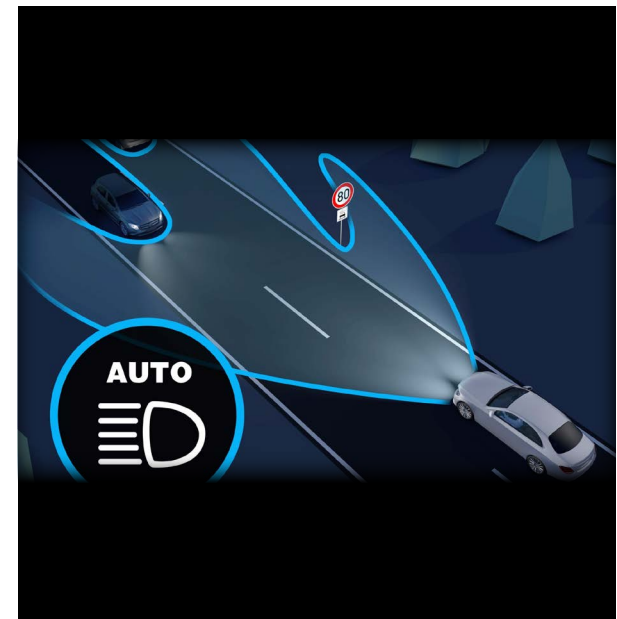
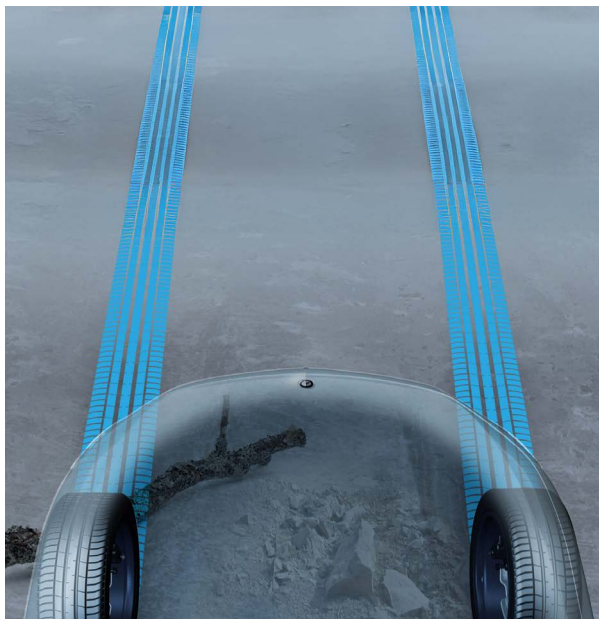

PARKING & MANEUVERING ASSISTANCE

Parking Package with 360° Camera: Provides all-around visibility, Active Parking Assist, and PARKTRONIC to make finding, parking, and unparking effortless.

Soft-Close Doors: Conveniently and quietly pull doors into the lock position, enhancing everyday usability.

DRIVING ASSISTANCE PACKAGE

Turn your GLS into a thinking partner with features designed for comfort and safety:

Active Stop-and-Go Assist: Reduces strain in stop-and-go traffic on highways.

Blind Spot Assist: Monitors your blind spots, providing visual and audible alerts during lane changes or door opening.

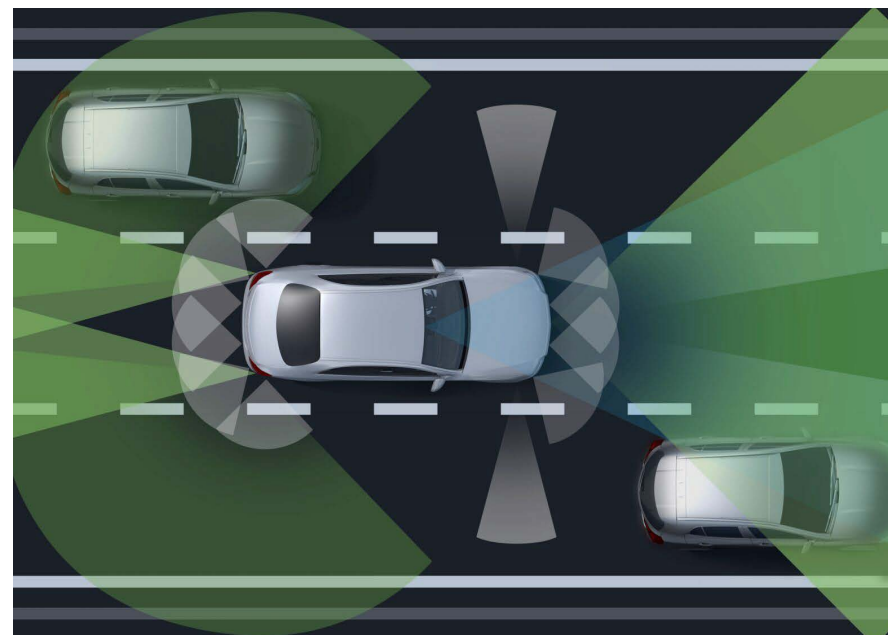
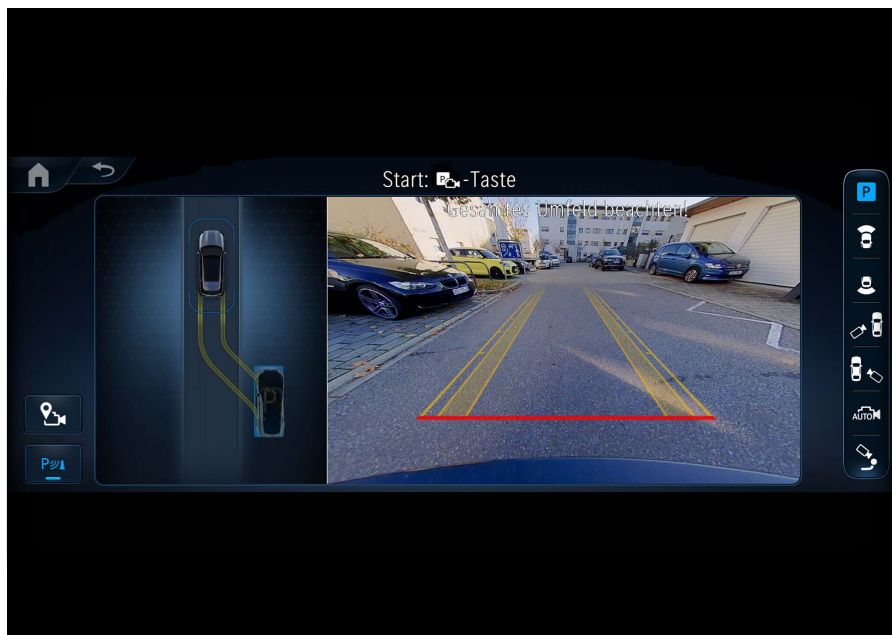

GENUINE ACCESSORIES & COLLECTIONS

MERCEDES - BENZ

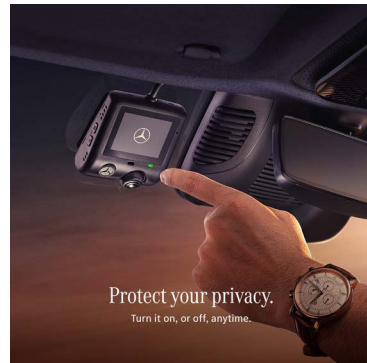

SAFETY & SECURITY

Stay protected with a 360° surround dashcam featuring 3-channel recording, seamless loop storage, and intelligent power management.



TRAVEL ESSENTIALS

Travel smarter with essentials like a spacious roof box, secure child seats, a handy cool box, and practical add-ons for added comfort on every journey.

GLS



EXTERIOR ENHANCEMENT & WHEELS

Elevate your vehicle's presence with premium exterior styling and wheel upgrades, featuring the AMG pattern LCD projector, roof spoiler, fuel filler cap, protective door handle recesses, and stylish alloys, hub caps, and valve caps for a bold, head-turning finish.



COLLECTIONS

Explore our exclusive collections, AMG, Mercedes-Benz, and Young Stars collection, featuring premium lifestyle merchandise like T-shirts, caps, key rings, mugs, and more to showcase your passion beyond the drive.



INTERIOR ENHANCEMENT

Enhance every drive with premium interior upgrades from elegant velour, durable ribbed, and all-season floor mats to sport pedals and illuminated door sills, all designed to elevate comfort, style, and everyday functionality.

FINANCIAL FREEDOM FOR YOUR JOURNEY

Whether you prefer the simplicity of a traditional ownership or flexibility of upgrading your car every few years, our financial solutions are designed to suit your lifestyle, we ensure your experience is seamless just like your drive.



STAR Finance

Offers a seamless solution for straightforward Mercedes-Benz ownership, getting you behind the wheel instantly.

- Choose a repayment period ranging from 12 to 84 months.
- You own the vehicle from the very start of the contract term.
- Know exactly what your repayments are with a consistent, fixed rate.

STAR Agility+

For those who value flexibility, STAR Agility+ offers an Assured Buy-Back Value that guarantees your vehicle's future worth.

- Loan term ranging from 12 to 60 months.
- Annual mileage allowance that reflects your driving needs.
- Lower monthly repayments and the highest residual value.
- Inclusive maintenance and an extended warranty

END-OF-CONTRACT CHOICES



Upgrade



Retain



Return

GET IN TOUCH TO FIND YOUR PERFECT PLAN >

Email: mbfsindia@mercedes-benz.com >

Disclaimer: Terms & Conditions apply. Finance is at the sole discretion of the financier, Mercedes-Benz Financial Services India Pvt. Ltd.



SERVICES

SERVICE AS SEAMLESS AS THE DRIVE



ADVANCE ASSURANCE PROGRAM

Extended warranty for long-term peace of mind
Continue your ownership journey with confidence beyond the standard 3-year warranty. The Advance Assurance Program extends warranty coverage up to 6 years at a nominal cost, ensuring sustained protection and worry-free driving.

STAR EASE

Predictable maintenance. Exceptional value.
STAR Ease maintenance packages offer fixed-cost servicing based on model, mileage and tenure. Enjoy freedom from service-related surprises, along with benefits such as priority handling, reduced waiting times and faster service processes.

MOBILO

24x7 on-road assistance, wherever you go
Mobilo provides round-the-clock roadside assistance for complete mobility assurance. Standard for 3 years and extendable up to 8 years, it includes benefits such as towing support, replacement vehicle and hotel accommodation when required.

DIGITAL SERVICE DRIVE

Convenient. Transparent. Hassle-free.
Designed around your schedule, Digital Service Drive ensures seamless service experiences with enhanced transparency and customer-friendly processes, so your vehicle care is always effortless.



PREMIER EXPRESS PRIME

Comprehensive service delivered faster

For customers who value time, Premier Express Prime enables quicker service turnaround without compromising on quality. A brief visit, a thorough service available at selected locations.

MERCEDES-BENZ GENUINE PARTS

Engineered for your Star

Crafted to exact Mercedes-Benz standards, Genuine Parts preserve performance, safety and comfort. Backed by a warranty of up to 2 years, they ensure reliability and long-term ownership confidence. Terms and conditions apply

MERCEDES-BENZ APPROVED TYRES & ALLOYS

Optimized for performance and safety

Approved tyres are precisely matched to your vehicle's dynamics, while approved alloys enhance both performance and visual appeal ensuring every drive remains safe, comfortable and engaging.

MERCEDES-BENZ GENUINE CHEMICAL PRODUCTS

Tested, approved & environmentally responsible

Specially developed to meet Mercedes-Benz material compatibility and quality standards, these products support your vehicle throughout its lifecycle while complying with stringent environmental norms.

TECHNICAL DATA

MERCEDES - BENZ

Total displacement / No./arrangement of cylinders
Rated output (kW (hp) @ rpm)
Rated torque (Nm @ rpm)
Transmission
Acceleration from 0 - 100 km / h (s)
Top speed (km/hr)
L x W x H (mm)
Engine electric motor
Gross weight

GLS 450 4MATIC AMG Line

2999 cc / R6
280 (381) / 5800-6100
500/1800-5000
9G-TRONIC
6.1
250
5209 x 2157 x 1823
(48V) output : 15 kW & 200 Nm
3250

GLS 450 d 4MATIC AMG Line

2989 cc / R6
270 (367) / 4000
750/1350-2800
9G-TRONIC
6.1
250
5209 x 2157 x 1823
(48V) output : 15 kW & 200 Nm
3300

GLS

The integrated starter alternator (ISG) electrically supports the combustion engine in certain operating states with up to 15 kW of additional power and up to 200 Nm more torque. You will particularly notice this benefit when you accelerate. On the other hand, electric support of the combustion engine also brings fuel consumption advantages. The ISG operates with a separate 48 V on-board electrical system.

DIMENSIONS

MERCEDES - BENZ

Side

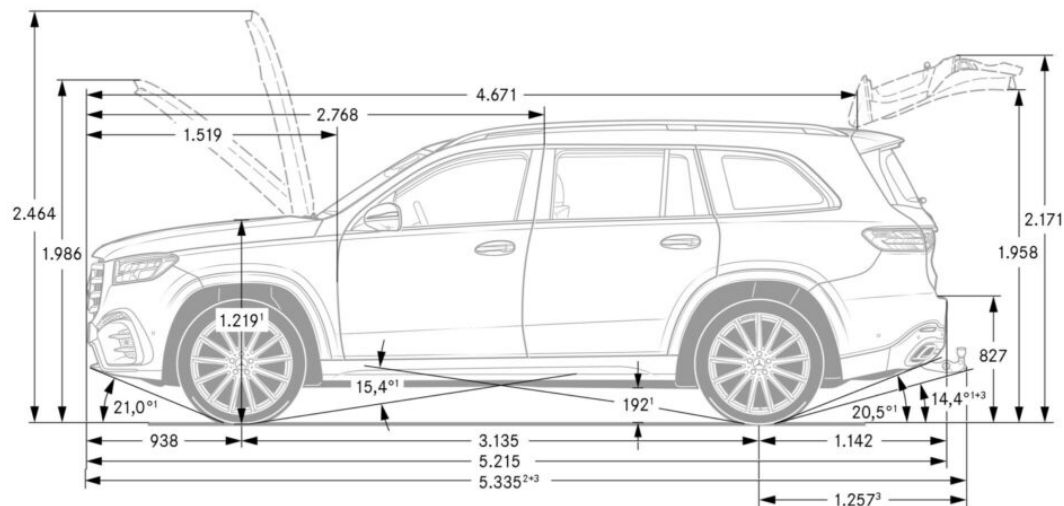

GLS

Rear

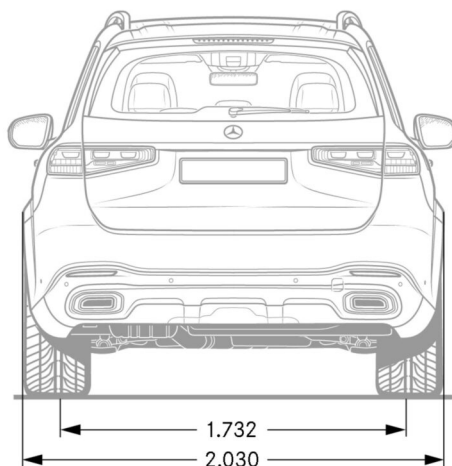

Front

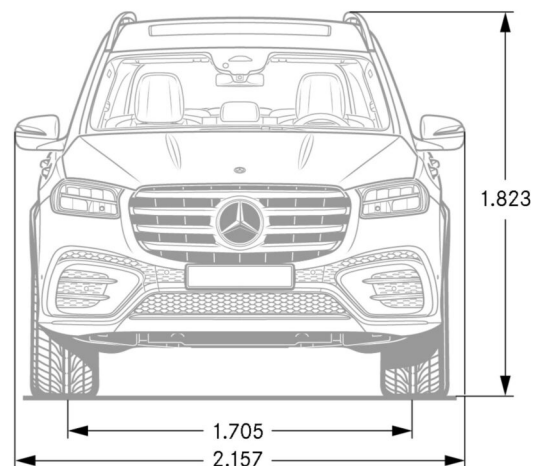



Mercedes-Benz India Private Limited: E-3, MIDC Chakan - Phase III, Chakan Industrial Area, Kuruli & Nighoje, Tal: Khed, Pune - 410 501 (India) Toll free No.: 0008000501888. e-mail: cs.ind@cac.mercedes-benz.com, website: www.mercedes-benz.co.in Please note: This brochure is intended for general information, description and illustration of the Product including optional functions and equipment and may not be specific to a Product since specification of a product may change from time to time. Optional features, functions and equipment etc. may not be present in the Standard or Variant Product or Special Edition Product. Further, Standard specifications of a product may also vary from time to time. Colours may differ from those shown in pictures in the brochure. Mercedes-Benz

35

Images shown are for representation purposes only. Some of the vehicles in the Brochure are left hand drive wheel. However, Mercedes-Benz India only manufactures and sells vehicles as per the applicable motor vehicle regulations in India. All vehicles sold by Mercedes-Benz Authorized Franchise Partners shall be with right hand drive wheels only. All title, ownership rights and intellectual property rights in and relating to this brochure/magazine or publication material or any copies thereof including but not limited to copyright, logos, names, trademarks, service marks, design, text, images, links, concepts and themes are owned by Mercedes-Benz Group AG and/or its subsidiaries collectively or used under authorised license by the Mercedes-Benz Group AG. Any reproduction, transmission, publication, performance, broadcast, alteration, license, creation of derivative works or other use in whole or in part in any manner without the prior written consent of Mercedes-Benz India Pvt. Ltd is strictly prohibited. Please note that certain services