

The New Mercedes-Maybach GLS 600.



MAYBACH



MAYBACH



Desire for Sophisticated Luxury.



Maybach and MBUX. Sounds like an exceptional combination.



Mercedes-Maybach GLS

Engine

Mercedes-AMG 4.0-litre V8 Engine

The Mercedes-AMG 4.0-litre V8 engine is characterised by spectacular power delivery with finely controlled power output. The twin-scroll turbochargers are located between the cylinder heads for better response. In addition, the engine is consistently electrified with mild hybrid and 48-volt electrical system. Cylinder deactivation at low power demand also reduces consumption.

Key features:

- Water-cooled engine control unit.
- Twin-scroll turbochargers with separate exhaust gas ducts for spontaneous boost pressure and torque build-up.
- Petrol particulate filter to reduce emission of soot particles.
- Electronically controlled fuel supply system for variable pressure control.
- Aluminum crankcase with closed-deck design for stiffer engine block.
- Light, sodium-filled NIMONIC® exhaust valves for stability under high loads.
- BlueDIRECT multiple injection and multi-spark ignition for optimal combustion and lower fuel consumption.
- NANOSLIDE® technology for ideal lubrication and resistance to wear.
- Lightweight forged aluminium pistons for high performance and low weight.
- Map-dependent shutoff of cylinders under partial load for lower fuel consumption.
- Cylinder heads alloyed with zirconium for efficient heat dissipation.
- Dynamic engine mounts adjust steplessly to the DYNAMIC SELECT drive program or driving conditions.





AIRMATIC package

Air suspension with adaptive damping system and automatic or needs-based regulation of the vehicle level. In the AIRMATIC package, an adaptive damping system meets modern air suspension. The result: an intelligent comfort chassis that can automatically adapt to the driving situation, speed and load. This means you benefit from balanced driving stability with first-class comfort.

Chassis with adaptive damping system





Mercedes-Maybach GLS

Design

Chrome package interior

Stylish design elements in silver chrome refine the interior. The chrome package sets additional elegant accents in the interior with selected design elements. Numerous bezels are stylishly finished in silver chrome, e.g. B. the EASY-ENTRY switch, the decorative elements in the interior door area and cup holders.



Ambient lighting with animated projection of the Mercedes-Maybach Pattern

Lighting of the exit area on the front and rear doors with LCD projection of the Mercedes-Maybach Pattern. The ambient lighting projects an animated Mercedes-Maybach pattern onto the floor when the doors are open. This means that the front and rear entry areas are comfortably illuminated. The staging of the brand logo using LCD technology is a real eye-catcher.



Ambient lighting

Elegant ambient lighting with 64 colors and 9 color worlds. The ambient lighting stages the interior with a total of 64 colors – entirely according to your personal preferences. The colors can also alternate spectacularly in 9 color worlds. This all-round lighting creates a feeling of security, especially in the rear.

Exclusive trim package

Additional decorative elements on the backs of the front seat backs and map pockets for an even more exclusive ambience. The Exclusive trim package gives your interior an individual look. Additional decorative elements on the backs of the front seat backs increase the perceived value of the interior.



Multifunction steering wheel in nappa leather

Elegant steering wheel in 3-spoke design with steering wheel shift paddles galvanized in silver chrome and touch control panels. The multifunction steering wheel in nappa leather combines fine materials with innovative ease of use. You can control the most important vehicle functions using the touch control panels without having to take your hands off the steering wheel.



Multifunction steering wheel in wood-leather version*

Elegant steering wheel in wood and leather in a 3-spoke design, with steering wheel shift paddles in silver chrome and touch control panels. The multifunction steering wheel in wood and leather combines elegant materials with innovative ease of use. The combination of supple leather and wood pampers with its pleasant feel and exclusive look. You can control the most important vehicle functions using the touch control panels without having to take your hands off the steering wheel.

*Chargeable



Electric sun blinds in the rear doors left and right

Electric sun blinds in the rear doors protect against prying eyes and intense sunlight. Electrically retractable and retractable sun blinds in the rear doors protect passengers from prying eyes and intense sunlight. The view to the outside is still possible.

Panorama sunroof

Generous glass roof with electric sun blind, anti-pinch protection and PRE-SAFE® locking function. With the spacious panoramic sliding roof you will experience a fascinating feeling of freedom and a pleasantly bright ambience in the interior. Viewed from the outside, your vehicle looks particularly exclusive.



Executive seats

Luxurious travel comfort thanks to individually adjustable seats, including adjustable backrest and leg rest. With the executive seats you can enjoy a continuous lying surface for a comfortable sleeping position on long journeys. At the touch of a button you can bring the seat back to an almost flat angle of up to 43.5 degrees and extend the leg rests electrically.



First class rear compartment*

Comfortable headrests for rear passengers with additional cushions, adjustable side bolsters and tilt adjustment. With the comfort headrests, your rear passengers can enjoy first-class seating comfort on every journey. The head and neck are relieved and supported by the adjustable side bolsters. Thanks to the tilt adjustment and an additional cushion, every passenger can find a comfortable head position

*Chargeable



Multicontour seats for driver and front passenger

Comfortable multi-contour seats with active cushions, hot stone massage effect, seat heating Plus and seat ventilation. The numerous adjustment options of the multi-contour seats allow you to find a perfectly fitting sitting position. Inflatable side cushions provide intensive lateral support. The gradually adjustable seat climate and the pleasant massage effects turn every journey into a pleasure.

*Please read the disclaimer

Multicontour seats in the rear

Comfortable multi-contour seats with massage function and lumbar support. With the multi-contour seats, your rear passengers enjoy the same comfort benefits as the driver and front passenger. The massage function offers targeted relaxation and the ergonomically shapeable backrest contour promotes a healthy posture.



THERMOTRONIC automatic climate control

Automatic climate control with 4 climate zones, fine dust activated carbon filter, defrosting system and residual heat function. 4 climate zones enable an individual feel-good climate on board. The driver and front passenger as well as the rear passengers can determine the temperature and air distribution according to their personal needs. The climate settings can be saved and recalled at the touch of a button.



THERMOTRONIC automatic climate control in the rear

Automatic climate control with 4 climate zones, with additional air conditioning for the 2nd row of seats and separate heating and cooling system as well as its own fan. An additional air conditioning system expands the THERMOTRONIC automatic climate control system. For individual climate comfort, the temperature and ventilation intensity can be regulated independently for each space. This means that all passengers can enjoy their desired comfortable climate.



AIR BALANCE package

Individual scenting of the interior including fragrance bottle “No. 8 Mood”, ionization of indoor air and improved air filtration. The AIR-BALANCE package individually scents the interior with a room fragrance that perfectly matches the character of your vehicle. Thanks to refreshing ionization and purifying filtering of the outside and inside air, the package contributes to improved air quality on board and increased well-being.

ENERGIZING AIR CONTROL

Monitoring of air quality including a two-stage filter concept. ENERGIZING AIR CONTROL monitors the air quality for you using air quality and fine dust sensors. A two-stage filter concept reduces fine dust and the majority of other inhalable pollutants. Depending on the measured value, your vehicle switches intelligently between fresh and recirculated air mode.

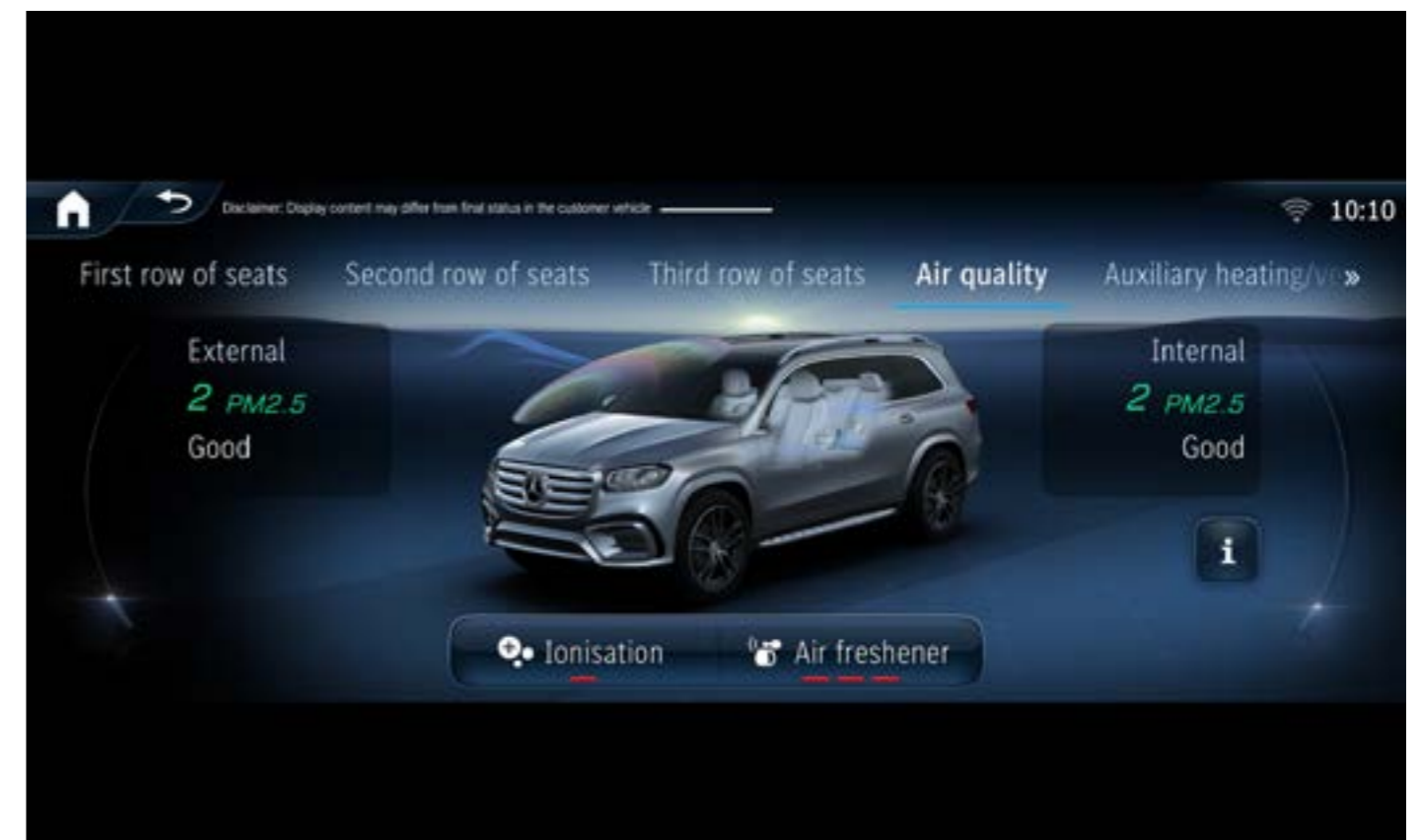

Seat on the passenger side electrically adjustable from the rear

Button in the rear for electrically moving the passenger seat. The rear passenger on the passenger side can move the passenger seat forward electrically at the push of a button. This creates a noticeably larger footwell, which enables a particularly relaxed sitting position and ensures a spacious feeling. For comfortable travel with more legroom in the rear.



Seat climate control in the rear

3-stage seat ventilation and 3-stage seat heating for a pleasant seating climate on the outer rear seats. The seat air conditioning ventilates the outer rear seats of the 2nd row of seats with a large air flow, cools them down and thus also regulates moisture. In cooler weather, the seat heating quickly brings the seat surfaces and backrests to a comfortable temperature.



Temperature controlled cupholders (front and rear)

Temperature-controlled cupholders in the center console cool or warm drinks for the driver and front passenger. With the temperature-controlled cup holders, cold or warm drinks are always within reach for the driver and front passenger. Bottles, cans and cups up to 0.5 l are securely fixed in the center console. Depending on your wishes, the temperature is kept in a range between 8° and 55° C.

Memory package

Memory function with up to 3 storage options, including for front seat and steering column settings as well as ENERGIZING seat kinematics. With individual position profiles you can save seat and mirror settings or the alignment of the steering column - particularly practical if your vehicle is used by different people. While driving, the ENERGIZING seat kinematics keep you active and relieve the strain on your back.



Seat climate control for driver and front passenger

3-stage seat ventilation and 3-stage seat heating for a pleasant seating climate. The seat ventilation supplies the front seats with a large airflow, cools them down and thus also regulates moisture. In cooler weather, the seat heating quickly brings the seat surfaces and backrests to a comfortable temperature.



Seat heating Plus in the rear

Fast three-stage seat heating for the outer rear seats with separate controls for seat surfaces and backrests. The seat heating Plus brings the seat surfaces and backrests of the outer rear seats to a pleasant temperature particularly quickly. This significantly increases seating and travel comfort, especially in cooler weather. The intensity can be selected in 3 levels. Over time, the seat heating switches back automatically.



Wireless charging system for mobile devices at the front

Wireless charging of your mobile devices in the spontaneous storage area. With just one movement of your hand, your smartphone is in its permanent place in the spontaneous storage area and is charged wirelessly there. Regardless of model and brand, Qi-compatible mobile devices charge wirelessly.

Wireless charging system for mobile devices in the rear

Inductive charging area for mobile devices in the storage compartment between the outer rear seats. The storage compartment between the two rear seats is also an inductive loading area. This means you can conveniently and wirelessly charge compatible mobile phones in the rear. All mobile devices that use the Qi standard are supported.



Mirror package

Your personal comfort thanks to, among other things, electrically folding exterior mirrors and automatically dimming interior mirror. You can fold the exterior mirrors electrically and make your vehicle slimmer at the touch of a button. Small parking spaces suddenly become big enough. The interior mirror can also register distracting headlights from behind. Depending on the glare and ambient light, it dims automatically and continuously.



High Pile Floor Mats

4 high-pile floor mats in the color of the equipment. The 4 high-pile floor mats are designed in the respective equipment color and fit perfectly into the interior design. The mats also protect the footwell from dirt - they can be removed, vacuumed or cleaned in no time.

Double sun visor

Pivoting and horizontally sliding double sun visors. The double sun visor for the driver and front passenger protects you even more effectively from unpleasant glare. Thanks to the additional swiveling and horizontally movable sun visors, you can protect yourself from glare from the front and sides at the same time. This is a noticeable increase in comfort, especially when the sun is low.

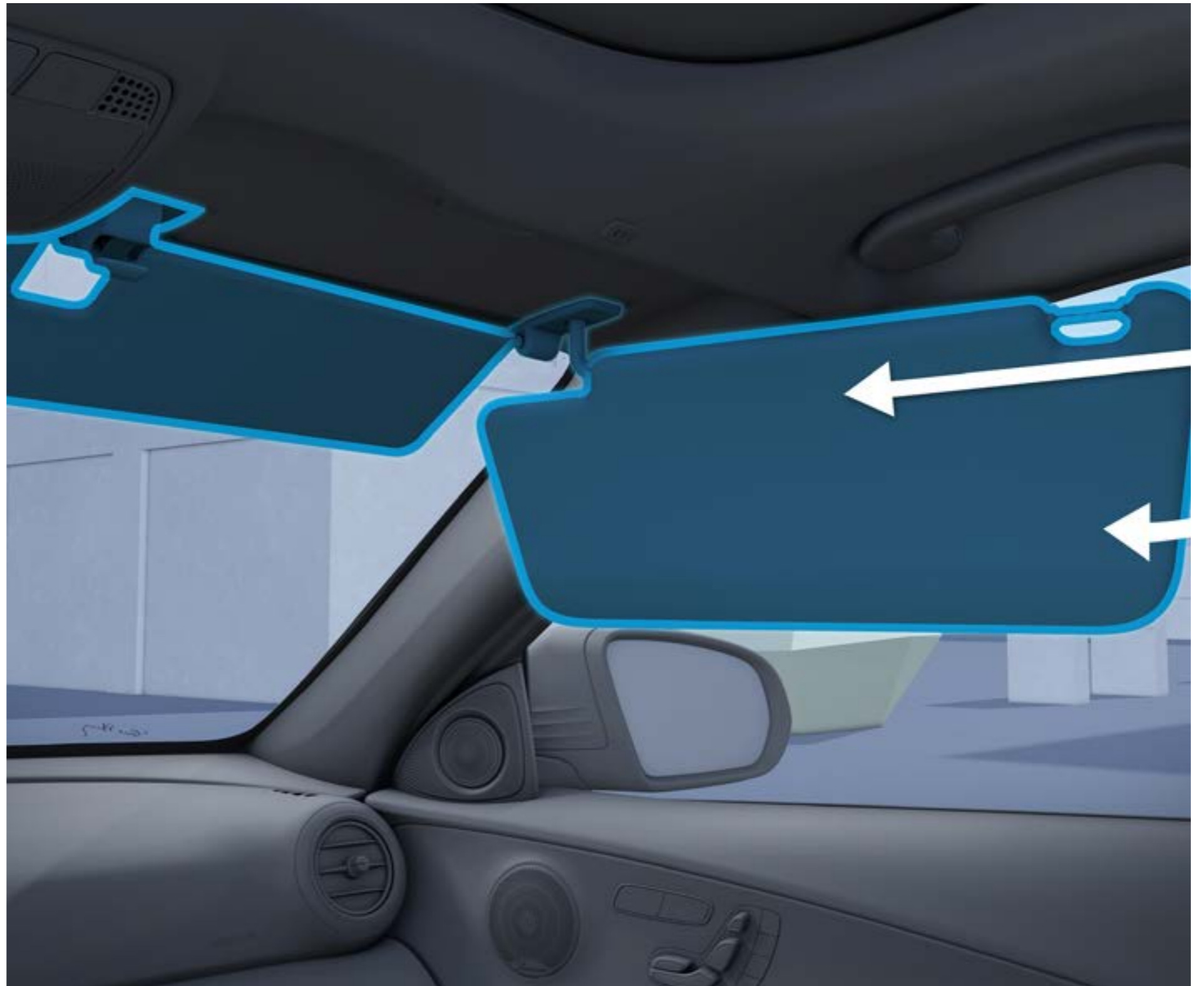



Mercedes-Maybach GLS

Comfort

Acoustic Comfort Package

Laminated safety glass for the front and side windows as well as additional insulation measures improve your noise comfort. The sound insulation of the Acoustic Comfort package significantly reduces annoying outside noises. Together with additional insulation measures, the laminated safety glass with acoustic film effectively reduces background noise. This means you can enjoy a quiet travel ambience even at high speeds.



KEYLESS GO

Convenient vehicle access including electronic vehicle key. With KEYLESS-GO, your key is recognized when you have it in close proximity to the vehicle and in the interior: All doors can then be opened and locked simply by touching the door handle. KEYLESS-GO access and driving authorization system: Thanks to the data stored in the key, the vehicle recognizes its owner within 2 meters of the respective vehicle door.



KEYLESS-GO comfort package

Convenient vehicle access including KEYLESS-GO access and driving authorization system as well as HANDS-FREE ACCESS. Start and lock your vehicle conveniently by simply carrying your key with you. With the HANDS-FREE ACCESS function, you can also open and close the tailgate fully automatically and without contact.



Power closing

Convenient electrical tightening and closing of vehicle doors. The servo closing function pulls your doors gently and almost silently into the lock. All you have to do is close the doors until they click into place - your vehicle will do the rest for you.

EASY-PACK tailgate

Electrically opening and closing tailgate with storable opening height. You can easily open and close the EASY-PACK tailgate electrically. This makes loading and unloading the luggage compartment even more convenient. You can easily start opening and closing at the push of a button and interrupt it at any time by pressing another button.





Mercedes-Maybach GLS

Technology



MBUX Interior Assistant

Contactless ease of use, including through natural and active hand movements. The MBUX Interior Assistant supports operation by reacting to body language. It records and interprets your hand and arm movements. You can activate selected functions, such as activating the search or reading light, literally in no time. The system can distinguish between driver and passenger.

Advanced functions MBUX

Adjust MBUX to your personal preferences: thanks, among other things, to the adaptive MBUX voice assistant*, personal profiles and prediction functions. The extended MBUX functions are tailored to you personally. Say “Hey Mercedes” – MBUX then waits for your wishes and learns thanks to the online connection. Personal profiles, prediction functions and a WiFi hotspot completely redefine digital networking.



MBUX rear tablet

WLAN-enabled MBUX rear tablet, including access to the MBUX multimedia system and 7.4-inch screen diagonal. With the 7.4-inch MBUX rear tablet, you can access the MBUX multimedia system and control comfort features like a remote control. Another plus point: The MBUX rear tablet shows you the contents of the MBUX multimedia system in addition to the media display and the screens of the optional MBUX high-end rear entertainment



Preparation for MBUX Entertainment

Your favorite music, always with you – thanks to integrated music streaming services and internet radio. Enjoy your favorite music thanks to preparation for MBUX Entertainment. You can choose from music streaming services and internet radio in your vehicle. You can easily purchase the data package you need through a selected third-party provider. Service availability may vary.



Burmester® high-end 3D surround sound system*

Exquisite high-end 3D sound with 29 speakers, 1,610 watts of system power and Dolby Atmos®. With 29 speakers and 1,610 watts of system power, you can enjoy the legendary Burmester® sound experience. You can adjust the impressive 3D surround sound individually to all seats. Your vehicle can also play music in Dolby Atmos® quality - for a particularly touching and engaging surround sound.

*Please read the disclaimer

*Chargeable

Burmester® surround sound system

Premium sound with 13 speakers, 590 watts of system power and Dolby Atmos®. With 13 speakers and 590 watts of system power, you can enjoy the legendary Burmester® sound. The high-performance speakers develop first-class surround sound. You can optimize this specifically for the front and rear seats, making your listening experience even more intense.





2 wireless headphones

2 wireless over-ear headphones with noise-cancelling technology for an optimal listening experience. The wireless headphones impress with their outstanding three-dimensional sound and high wearing comfort. Active noise reduction effectively eliminates ambient noise. The best conditions for peace and first-class listening pleasure.

Sound Personalization

Digital setup assistant for the perfect sound setup for your Burmester® sound system. A digital setup assistant works with you to determine your music preferences and adjusts the Burmester® sound system to your wishes. He saves the result in a personal profile. This is how you can easily achieve your perfect sound setup.

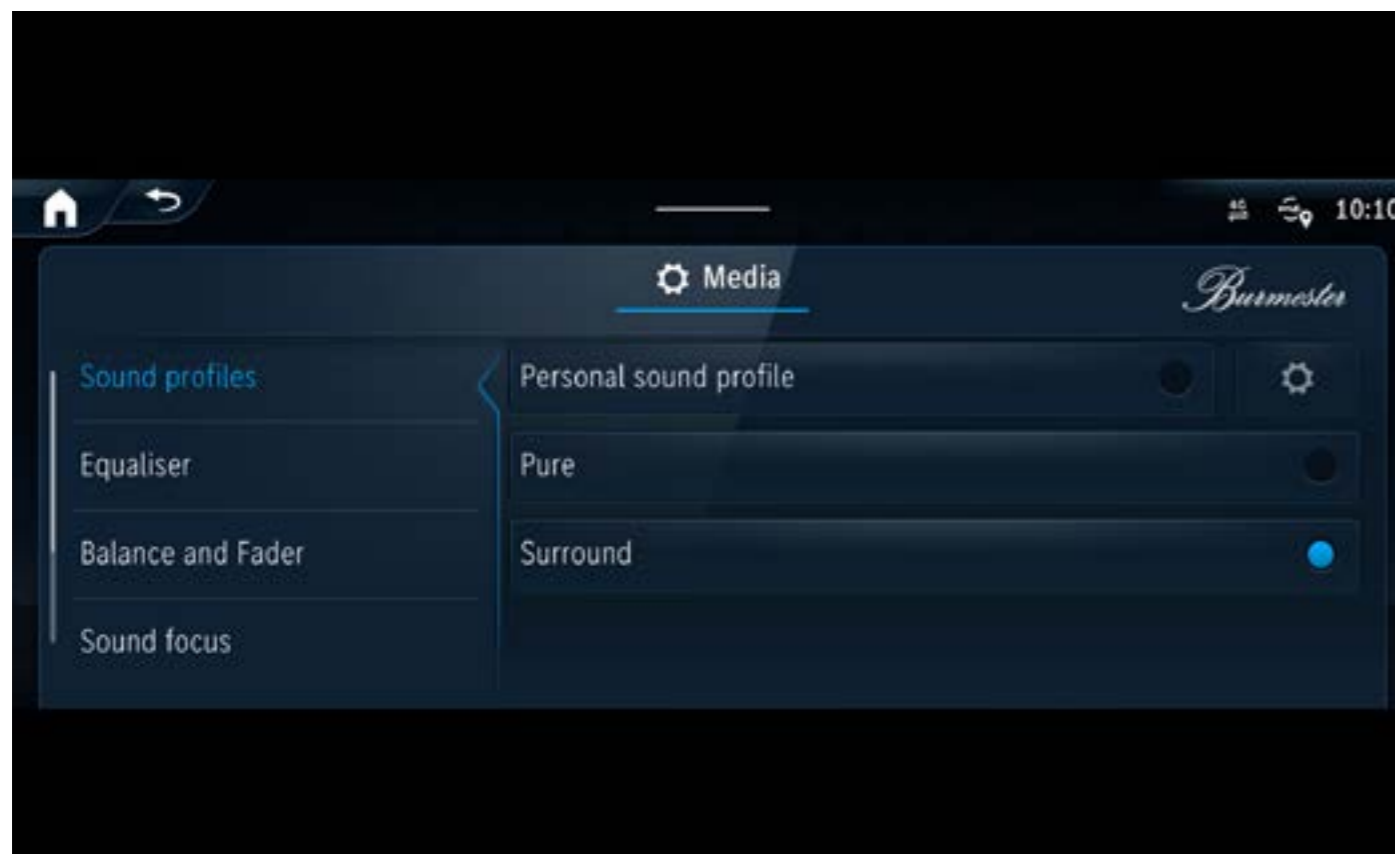

Preparation for navigation services

Display of online content in the navigation map*, including weather information or free parking spaces as well as a digital logbook. Wherever you go, being prepared for navigation services will keep you well informed. Your vehicle will answer your questions about your trip. You can find out the number of currently available parking spaces or the current weather. Helpful extra: The digital logbook* automatically records your journeys if desired.



Preparation for digital key handover

Share your vehicle conveniently with family and friends using the Mercedes me app. Share your vehicle with friends and family members - no matter where you are and simply via the Mercedes me app. You remain in control and decide who you leave your Mercedes to. You can use the app to unlock your vehicle remotely and activate the stored vehicle key for the user in the vehicle.

Smartphone integration

Connect your mobile phone wirelessly to the MBUX multimedia system via Android Auto™ or Apple CarPlay™. The smartphone integration wirelessly connects the mobile phone to the MBUX multimedia system via Apple CarPlay™ and Android Auto™. This gives you convenient access to the most important applications on your smartphone. You can also use third-party apps such as Spotify quickly and easily.

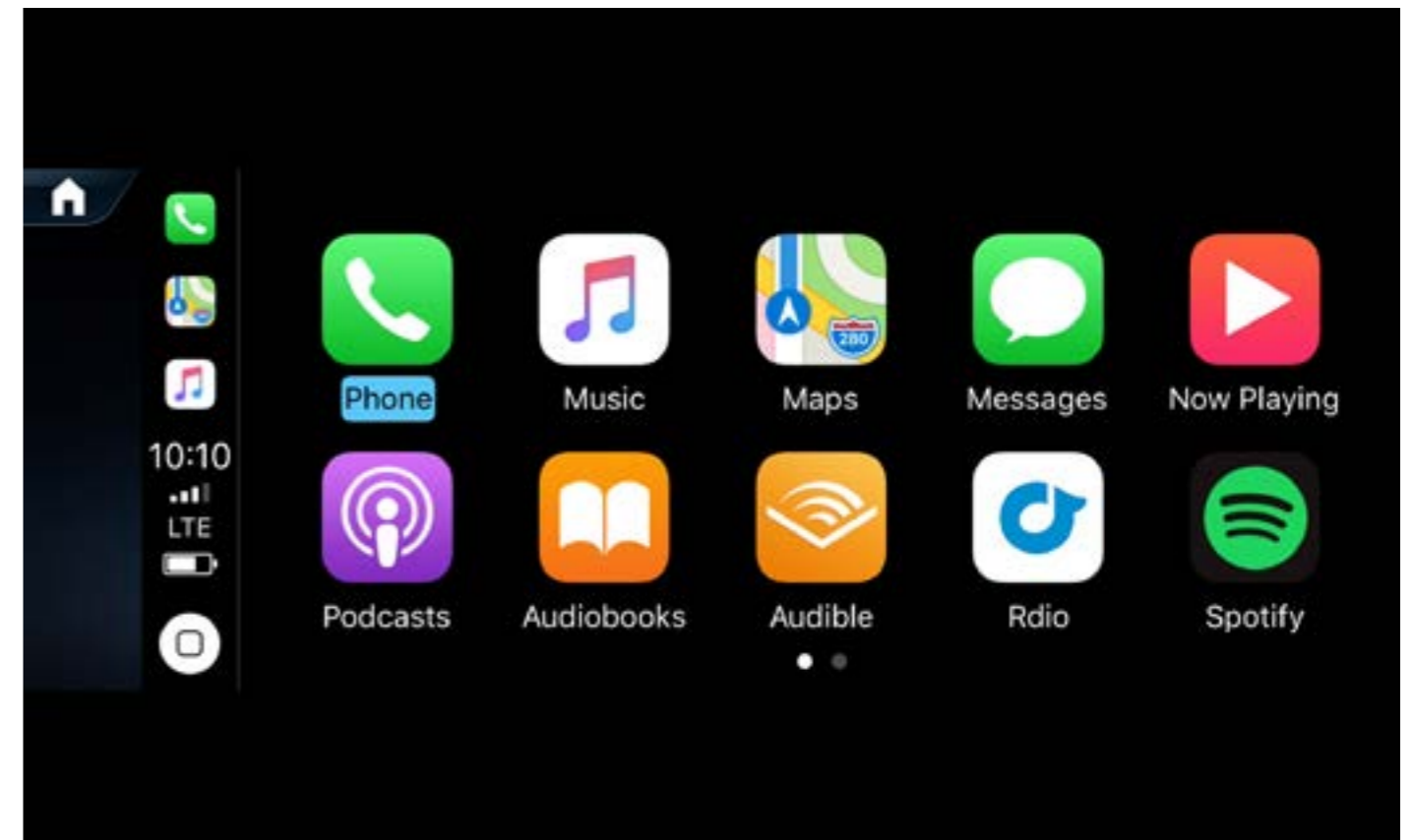

Apple Carplay

Connect your mobile phone wirelessly to the MBUX multimedia system via Android Auto™ or Apple CarPlay™. Smartphone integration wirelessly connects the mobile phone to the MBUX multimedia system via Apple CarPlay™ and Android Auto™. This gives you convenient access to the most important applications on your smartphone. You can also use third-party apps such as Spotify quickly and easily.

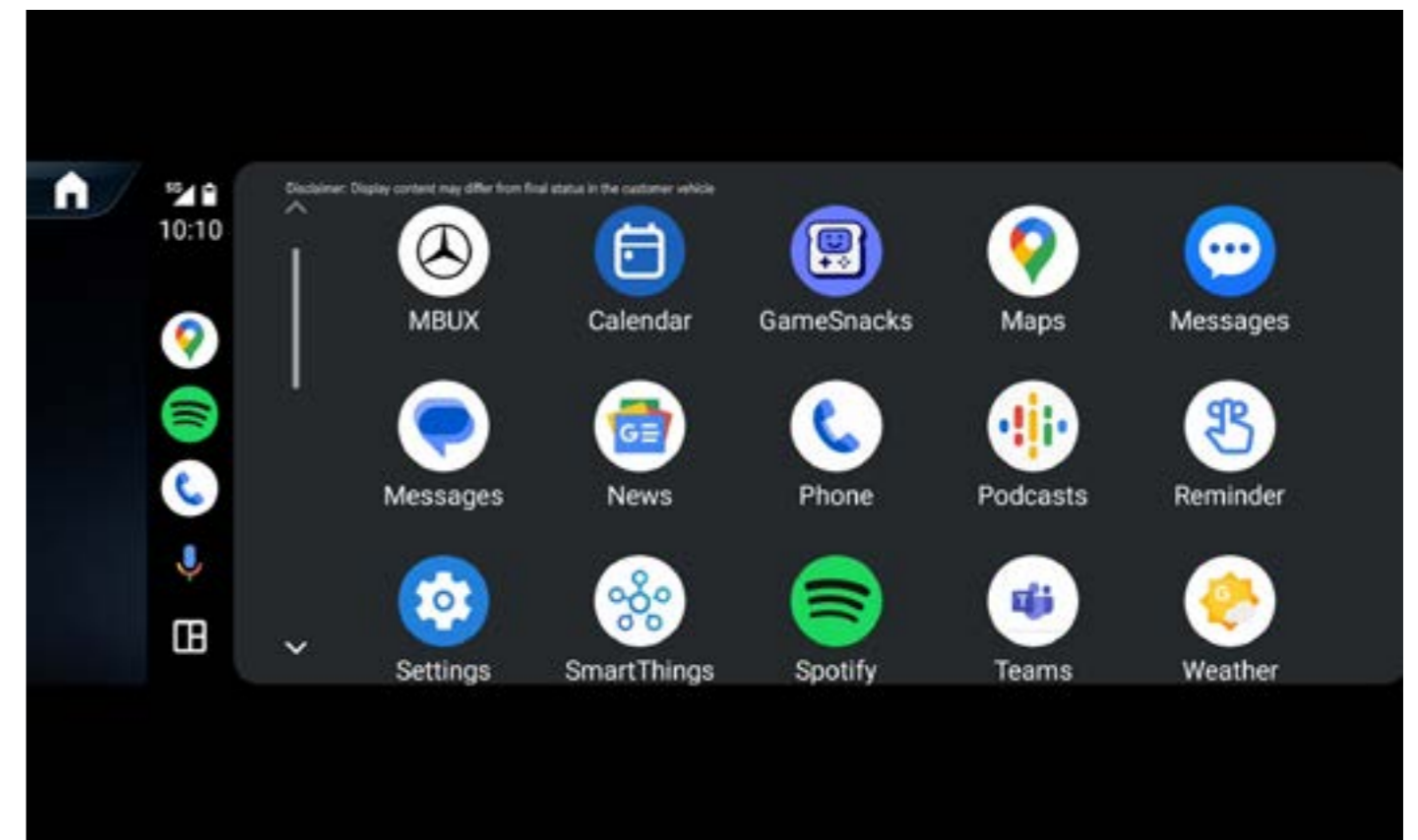
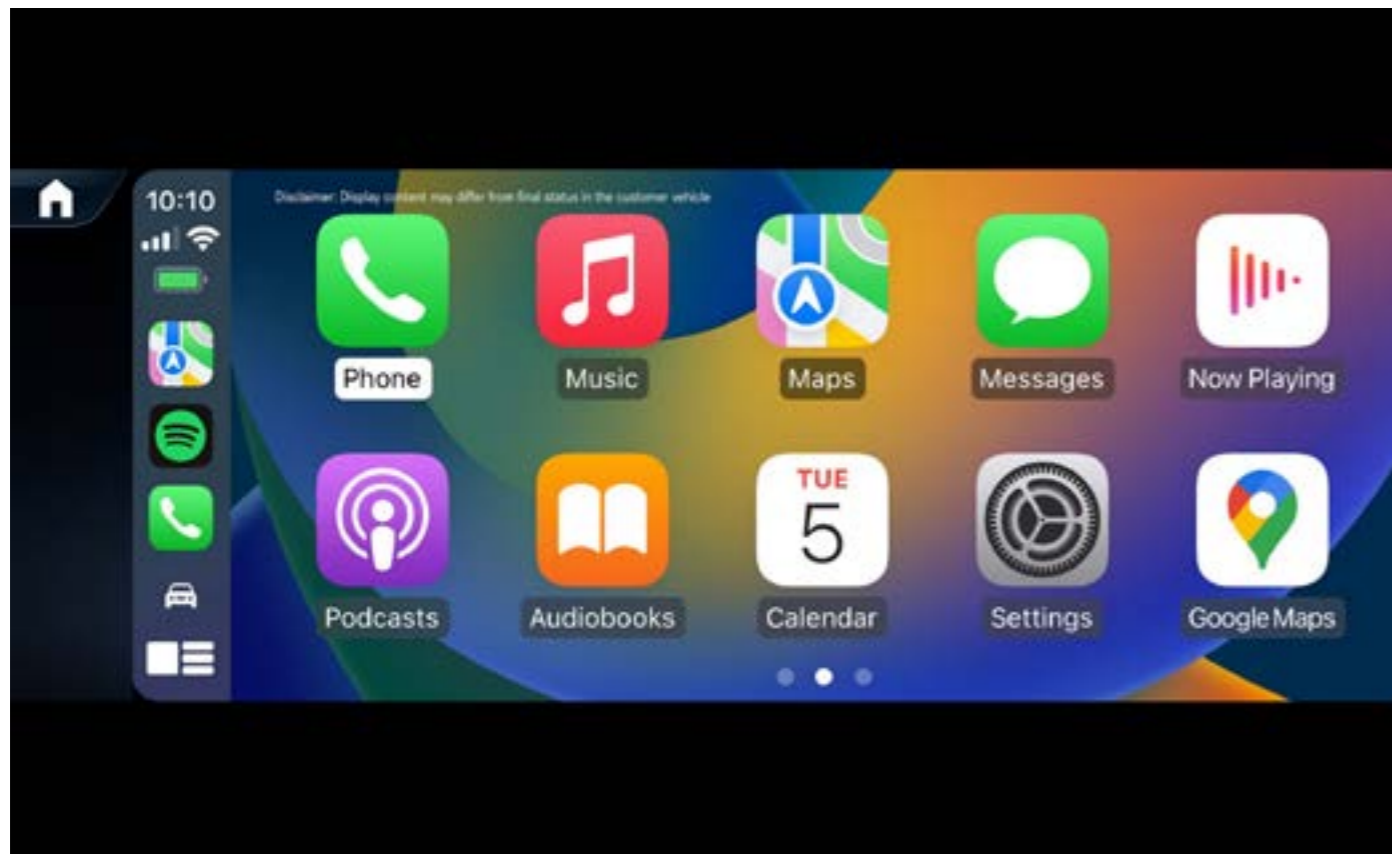

Android Auto

Connect your mobile phone wirelessly to the MBUX multimedia system via Android Auto™ or Apple CarPlay™. Smartphone integration wirelessly connects the mobile phone to the MBUX multimedia system via Apple CarPlay™ and Android Auto™. This gives you convenient access to the most important applications on your smartphone. You can also use third-party apps such as Spotify quickly and easily.



2 USB ports in the rear

2 USB-C ports in the rear with 100 W charging power for your mobile devices. Thanks to the 2 USB ports in the rear with charging power increased to 100 watts, you can quickly supply suitable smartphones, tablets and other devices with power even during short journeys.

Additional USB interfaces

A total of 7 USB-C ports for your mobile devices. With a total of 7 USB interfaces, you and your passengers can easily charge mobile devices. The connections also make it possible to connect and control the devices with your vehicle.



Head-up display

Head-up display to show information such as speed or navigation instructions. The head-up display turns your windshield into a digital cockpit. With the virtual image you always have important information directly in view. Your full attention is on the road and the traffic in front of you.



Transparent hood

Virtual view of the area immediately in front of the vehicle for improved maneuvering on off-road trips. The virtual view shows the area directly in front of your vehicle when driving off-road. This means you can maneuver confidently and avoid obstacles safely – even on rough terrain. Calculated from camera images, the hood appears transparent on the media display. Visualization of the lane helps to choose the optimal route.



Mercedes me connect allows drivers to stay in touch with their vehicles from anywhere in the world and to obtain assistance at the touch of a button.

Mercedes *me*

Vehicle Monitoring

Vehicle Tracker: Track your vehicle from anywhere, as your vehicle's GPS coordinates are seen on your phone App.

Parked Vehicle Locator: It can locate your parked vehicle within a radius of 1.5 kilometres and show you on a map how to make your way back to the vehicle.

Navigation Connectivity package

The combination of the standard-fit communication module (LTE) and the hard-disc navigation makes sure that you always reach your destination as quickly as possible by the best route.

Vehicle Set-Up

Remote Retrieval of Vehicle Status: Information on Mercedes me App or the Mercedes me Portal.

Remote Door Locking and Unlocking: You can conveniently remotely lock or unlock your vehicle from the Mercedes me App.

Speed Alert: Receive an alert if your vehicle exceeds a certain speed.

Send2Car function: Send your address to your vehicle via an app.

Remote Engine Start

Mercedes-Benz emergency call system

The Mercedes-Benz emergency call system can save you vital minutes in an emergency. If an accident is detected, a communications module with its own SIM card automatically triggers an emergency call which could shorten the time until rescue services arrive.

Please note that certain services are offered free of cost for a period of three (03) years and may be chargeable at the expiry of three (03) years from the date of activation of such services. If you wish to continue using those services, you may renew the same through Mercedes Me Store (as and when it is available). Please get in touch with your preferred Franchise Partner for more details.

Mercedes me

Vehicle Finder (enables horn and light flashing)

Find your vehicle in large parking lots with ease. Simply blow the horn or flash the headlamps through the app to locate your vehicle

Mercedes me Service app: Your digital assistant

Keep a tab on your Star's maintenance with ease. Get timely maintenance and service reminders. Book a service appointment and search for nearest showrooms with a single touch.

What's more, access expert tips to keep your Star in its best shape with car care videos.

Geo-fencing

Set a perimeter for the car movement and receive notifications in case of vehicle movement beyond the parameter. Hence the feature enables easy monitoring when vehicle is being driven by others.

Windows/sunroof open close from App

Open/Close the windows and sunroof of your Mercedes-Benz remotely through the app. This enables better ventilation before you get into the car.



Mercedes me

Additional Mercedes me connect features

Alexa Home Integration with Mercedes me

connect: Conversations with Alexa are now more fun when the systems connect with your Mercedes Benz via cloud and give you real time updates. This feature can be used from an Alexa Echo device setup at home, office or also from phone's Alexa App. The command starts with "Alexa, Ask Mercedes to..." or directly initiate a command by saying "Alexa, tell Mercedes to <command>".

Google Home integration with Mercedes me connect: Google Home integration is also offered for Google home users. In a similar way, once the Mercedes me connect is linked to Google Home, you can start issuing commands.

Parking location POIs (Points of Interest): The introduction of new Parking solution, shows Parking lots available across different parts of the cities. The Parking POIs (Points of interest) can be seen easily on the navigation system or alternatively also on the Mercedes me App maps section.



Please note that certain services are offered free of cost for a period of three (03) years and may be chargeable at the expiry of three (03) years from the date of activation of such services. If you wish to continue using those services, you may renew the same through Mercedes Me Store (as and when it is available). Please get in touch with your preferred Franchise Partner for more details.



Mercedes-Maybach GLS

Safety

Multibeam LED

Adaptive LED headlights, including intelligent light modes, active cornering lights, ULTRA RANGE high beam and Adaptive High Beam Assistant Plus. The adaptive MULTIBEAM LED headlights illuminate the road for you according to the situation thanks to intelligent lighting functions. The headlights react to the current traffic situation using individually controllable LEDs. This means you can enjoy excellent visibility.



Adaptive High Beam Assist Plus

Permanent high beam without dazzling oncoming traffic by leaving out the oncoming traffic or traffic in front. With the Adaptive High Beam Assist Plus, you can drive with constant high beam without dazzling others. The intelligent system uses high-precision LEDs to avoid oncoming traffic or vehicles in front. This means you don't have to constantly switch to low beam and can see the road and dangers better thanks to the long headlight range.



Sidebags in the rear

Side airbags in the rear can protect the chest area in the event of a side impact. The side airbags in the rear can protect the chest area on the outer rear seats in the event of a serious side impact. To do this, air cushions are pushed between the door side or rear side panel and the passenger. Together with the standard window bags, they can help prevent injuries or reduce their severity.

Knee bag

Kneebag to protect the legs in the event of a serious frontal crash. The kneebag protects your legs from contact with the steering column or instrument panel in the event of a serious frontal crash. This can prevent or mitigate injuries. The air cushion unfolds in milliseconds and stabilizes the entire body. This means that the entire restraint system, including the seat belt, works together as well as possible.



GUARD 360° vehicle protection

Vehicle protection including burglary and theft alarm system, theft and collision notification and towing protection. The GUARD 360° vehicle protection offers all-round monitoring of the vehicle's surroundings - for example with the burglary and theft alarm system and towing protection. Movements in the interior trigger visual and acoustic warnings. The theft and collision notification from Mercedes me informs you via app.

GUARD 360° vehicle protection Plus*

Extended vehicle protection including burglary and theft alarm system as well as emergency key deactivation*. GUARD 360° Vehicle Protection Plus offers all-round monitoring of the vehicle's surroundings. Thanks to the burglary and theft alarm system as well as emergency key deactivation*, you can act quickly. When you're on the move, collision detection* notifies you via the app. In addition, the Vehicle Theft Assistance* service increases the chance of recovering your property.





Burglary and theft alarm system with preparation for collision detection

Visual and acoustic warning system in the event of attempted break-ins and theft, including notification of registered parking damage. Protect your vehicle and your valuables in the interior: This passive burglary and theft alarm system can be activated by you if necessary. This means that all protective measures are active that can prevent break-ins, theft and unauthorized towing. The system therefore meets the security regulations of various insurers.

GUARD 360° burglar-resistant laminated safety glass with heat and noise insulation

Laminated safety glass with acoustic and infrared protective films all around. The sound insulation significantly reduces annoying outside noises. Relaxed conversations are possible even at high speeds. The special glazing together with the optimized heat protection can maintain your concentration for a relaxed ride.

Driving Assistance Package Plus

Partially automated driving, including Active Distance Assist DISTRONIC, Active Steering Assist and Active Blind Spot Assist. Enjoy the benefits of partially automated driving. Systems such as Active Distance Assist DISTRONIC or Active Blind Spot Assist can provide you with support appropriate to the situation, warn you if there is a risk of collision and intervene if necessary. The intelligently networked sensor system uses cameras, radar and ultrasound to record your vehicle surroundings.

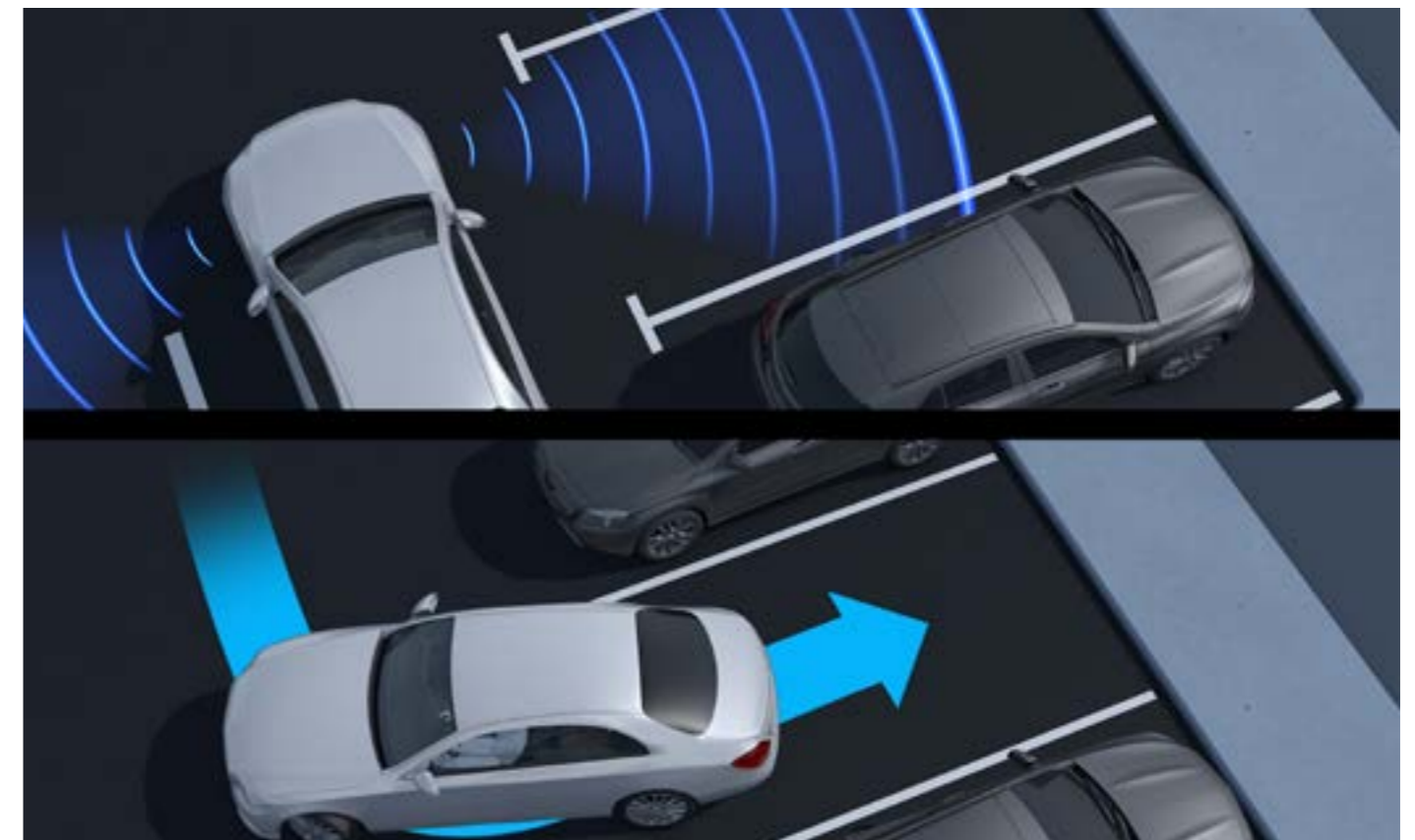

Active Parking Assistant with PARKTRONIC

Assisted reverse parking including PARKTRONIC. The Active Parking Assistant with PARKTRONIC can not only find parking spaces - it also supports you when reversing into parking spaces. It assists with steering, accelerating, braking and changing gears.

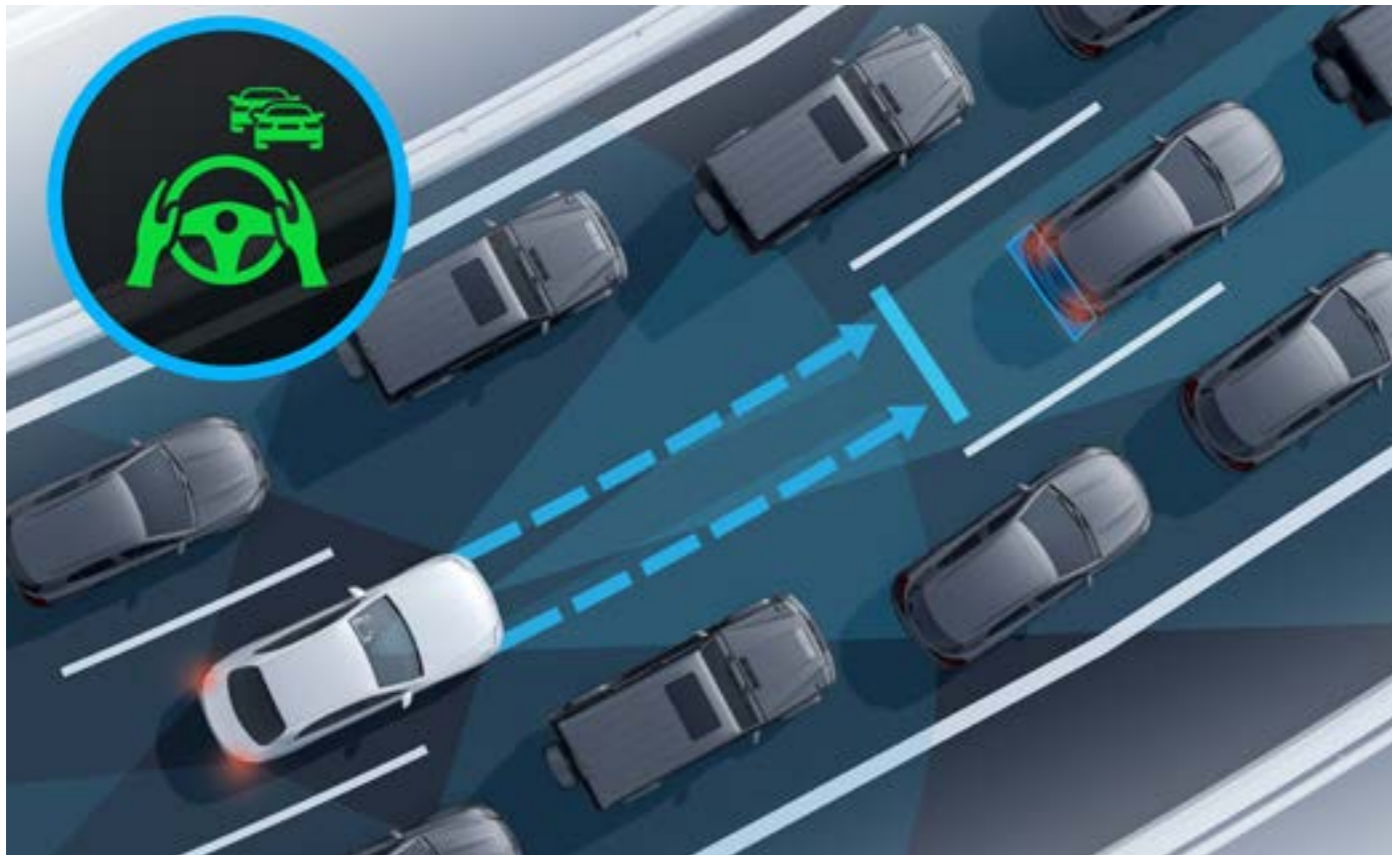

Active Steering Assistant

Keeps your vehicle on track, including active emergency stop assistant with SOS function and emergency lane function. The Active Steering Assistant can help you keep your vehicle in the middle of the lane using gentle steering interventions. The system is a great relief, especially on monotonous routes with straight and slightly curved sections.

Mercedes-Benz emergency call system

Automatic emergency call in the event of traffic accidents including transmission of position data and estimated number of people. The Mercedes-Benz emergency call system can provide decisive time savings in an emergency. If an accident is detected, an emergency call is automatically triggered via a communication module with its own SIM card, which can shorten the time until emergency services arrive. The emergency call can also be triggered manually to organize help.



360° camera

All-round view with 4 networked cameras and virtual bird's eye view. The all-round view of the 360° camera, including a virtual bird's eye view, helps you with parking and maneuvering. Thanks to the intelligent networking of 4 cameras, you can also see obstacles that are actually outside your field of vision via the central display.

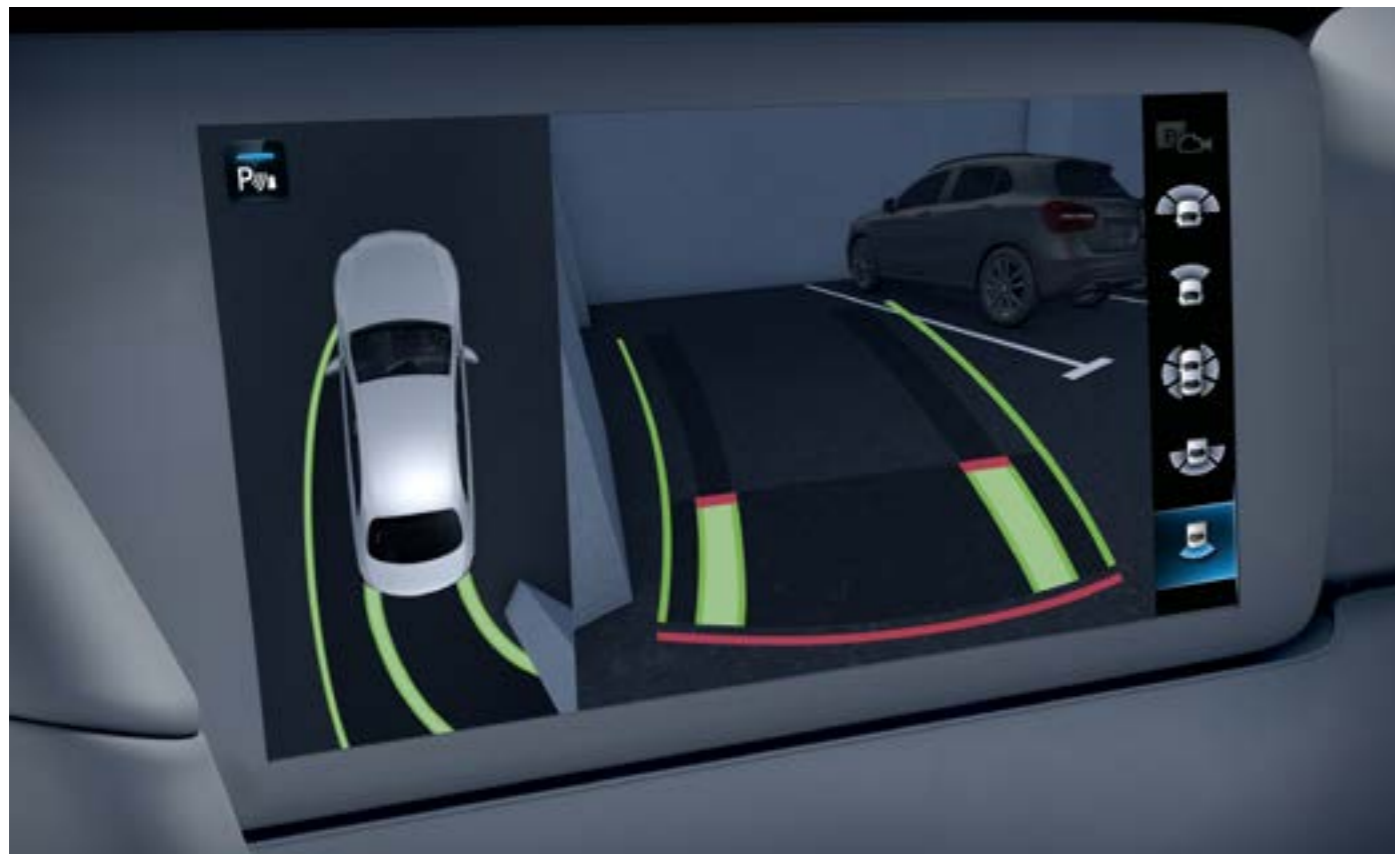

Technical underprotection

The technical underprotection can protect the underbody from damage and reduce contamination of the engine compartment. The technical underprotection can protect the underbody of your vehicle from damage when driving off-road. In addition, it shields the engine compartment and thus effectively reduces contamination.

Paintwork

Polar White



Emerald Green



Obsidian Black



Selenite Grey



Sodalite Blue





Alloy

55.9 cm (22-inch) Maybach light alloy wheels in multi-spoke design.



MBUX high-end rear entertainment

2 fully integrated touch displays, each with a screen diagonal of 11.6 inches and extensive connection to the MBUX multimedia system. With 2 fully integrated 11.6-inch touch displays, you can experience the best entertainment in the rear, even while driving. Thanks to the connection to the MBUX multimedia system, you can enjoy films in brilliant picture quality or surf the Internet. If necessary, you can also access various trip information.

Cup holder temperature controlled in the rear

Cold or warm drinks for your rear passengers thanks to temperature-controlled cup holders. With the temperature-controlled cup holders, cold or warm drinks are always within reach for your rear passengers. Bottles, cans and cups up to 0.5 l are securely fixed in the center console. Depending on your wishes, the temperature is kept in a range between 8° and 55° C.



MAGIC VISION CONTROL

Clear visibility, thanks, among other things, to heated wiper blades and washer fluid hoses as well as a tip wash function. MAGIC VISION CONTROL gives you a perfect view even during the wiping process. Heated water ducts are used in the windshield wipers. These spray the cleaning fluid onto the windshield directly in front of the wiper blades - where it is needed.



ENERGIZING package

ENERGIZING comfort control for longer performance, including 4 comfort programs, ENERGIZING COACH* and heated front seats. The ENERGIZING comfort control intelligently combines various comfort programs and functions. Your vehicle can revitalize you in a targeted manner - for longer performance behind the wheel and a pleasant journey.

Vehicle key in high-gloss black with decorative frame in high-gloss





Mercedes-Maybach GLS

MANUFAKTUR

MANUFAKTUR leather package

Extensive coverings in nappa leather throughout the interior, including upholstered cushions, interior headliner and front seat console. The finest nappa leather surrounds you throughout the entire interior - from exclusive upholstery cushions for the executive seats to the roof lining with distinctive decorative stitching. The MANUFAKTUR leather package takes the feel-good atmosphere and luxurious flair in your vehicle to a new level.



MANUFAKTUR Leather Package Exclusive

Extensive covers in nappa leather or ARTICO man-made leather in nappa look, including the dashboard cover. Refine your interior with the MANUFAKTUR Exclusive Leather Package. Even the window frame is covered with the finest nappa leather. The side instrument panel covers on the driver and passenger sides are also covered in the respective equipment color.

Folding tables in the rear

Mechanically foldable folding tables in the armrest in the rear. 2 folding tables transform the business console of the first-class fund into a comfortable work surface in no time - your rolling office. The shelves offer space for notebooks or documents. In keeping with the noble surroundings, they are covered in high-quality leather in the respective equipment color.





Refrigerator compartment

Cooling compartment in the rear armrest with a capacity of 9.6 liters. Chilled drinks are always within reach: the cooling compartment holds 9.6 liters and fits harmoniously into the rear armrest. This means you can enjoy refreshing cold drinks even when the outside temperature is higher. You can switch the refrigerator compartment on or off as needed using an on/off switch with an indicator light. You can also use 2 additional buttons to select the temperature (approx. + 4° C or approx. + 15° C).

Holder for champagne flutes

Tailor-made cup holders in the refrigerator compartment and in the rear center console. These inserts offer a stylish way to hold two champagne flutes. The tailor-made goblet holders in the refrigerator compartment and in the rear center console are perfectly adapted to the exclusive Maybach champagne goblets.



E-ACTIVE BODY CONTROL

Fully active chassis with automatic adaptation to the driving situation and 4 DYNAMIC SELECT driving programs. With the fully active E-ACTIVE BODY CONTROL suspension, you can drive confidently in any situation. With the first-class pitch, roll and shock compensating effects, you experience comfort, precision and dynamics - combined with unique off-road properties.

ENERGIZING Package Plus

In addition to the contents of the ENERGIZING package, you also receive multi-contour seats and seat climate control, each for the driver and front passenger. Seat climate control, the heat comfort package and multi-contour seats with massage function: This package combines attractive premium features with the ENERGIZING comfort control. Your vehicle can revitalize and pamper you – for longer performance behind the wheel and an extremely pleasant journey.



MANUFAKTUR Paintwork

MANUFAKTUR diamond white bright



MANUFAKTUR hyacinth red metallic



MANUFAKTUR alpine grey solid



Maybach two-tone paint MANUFAKTUR Obsidian Black /
Kalahari Gold



Maybach two-tone paint Obsidian Black / Rubellite Red



Maybach two-tone paint Emerald Green / Mojave silver



MANUFAKTUR Upholstery



MANUFAKTUR crystal white silver gray pearl



MANUFAKTUR mahogany brown macchiato beige



Nappa leather black

MANUFAKTUR Trim



Decorative elements brown walnut open-pored wood



MANUFAKTUR piano lacquer flowing lines black glossy



Decorative elements wood, anthracite open-pored oak

MANUFAKTUR designo roof liners



MANUFAKTUR Interior headliner leather nappa crystal white



MANUFAKTUR interior headliner leather nappa black



MANUFAKTUR interior headliner microfiber MICROCUT macchiato beige



MANUFAKTUR headliner leather nappa macchiato beige



Interior headliner microfiber MICROCUT black

Alloy



58.4 cm (23-inch) Maybach forged wheels in multi-spoke design



58.4 cm (23-inch) Maybach forged wheels in 5-hole design

Genuine Accessories

Wheel changing tool

Tool for quickly loosening wheel nuts. With the wheel changing tool you can loosen wheel nuts quickly and easily - for easy wheel changes.



Technical Data

Mercedes-Maybach GLS 600

Total Displacement (cc)	3982
No./Arrangement of cylinders	V8 biturbo with EQ Boost
Transmission	9G-TRONIC
Rated Output (kW (HP) @ rpm)	410 (557) @ 6000 - 6500
Rated Torque (Nm @ rpm)	770 @ 2500 - 5000
On-board Electrical System	48 V
Acceleration 0-100 (s)	4.9
Top Speed (km/h)	250
Fuel Tank Capacity/reserve (l)	90/9
Gross Vehicle Weight (kg)	3250
L x W (ORVM) x H	5205 x 2157 x 1838

The integrated starter alternator (ISG) electrically supports the combustion engine in certain operating states with up to 16 kW of additional power and up to 250 Nm more torque. You will particularly notice this benefit when you accelerate. On the other hand, electric support of the combustion engine also brings fuel consumption advantages. The ISG operates with a separate 48 V on-board electrical system.

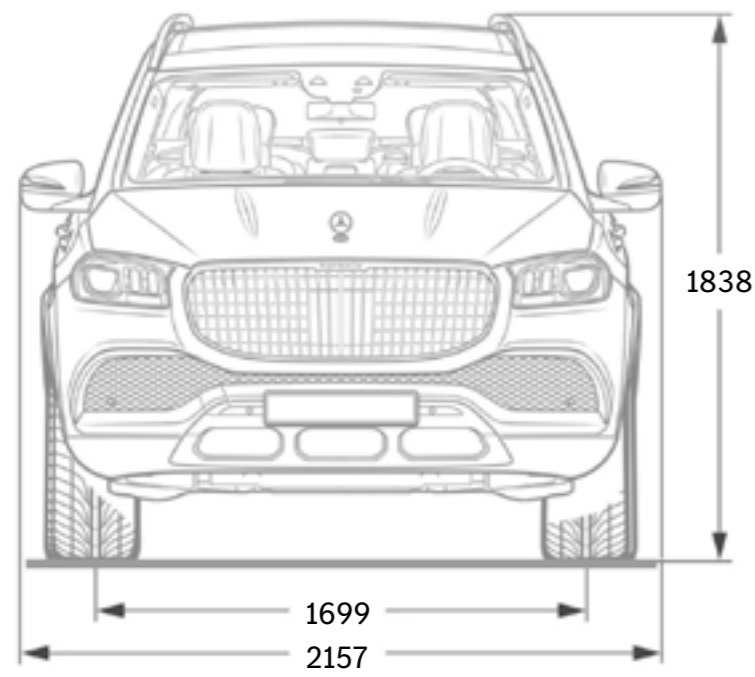

Front

Rear

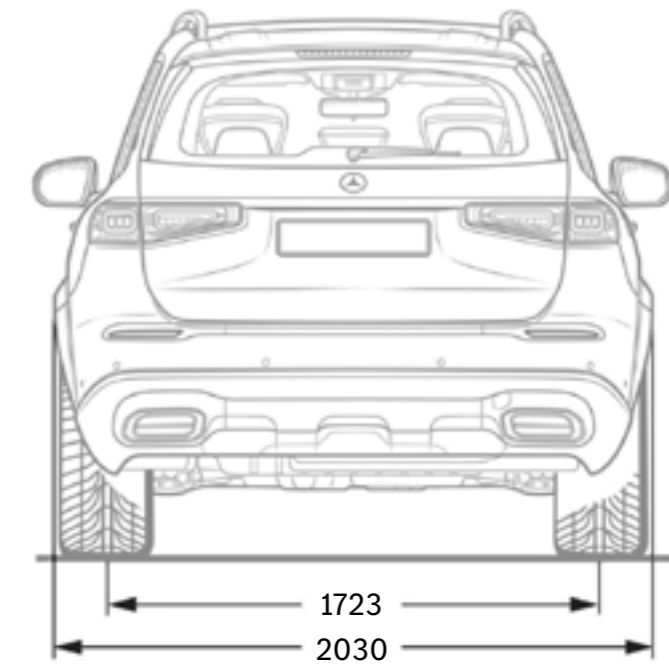

Side

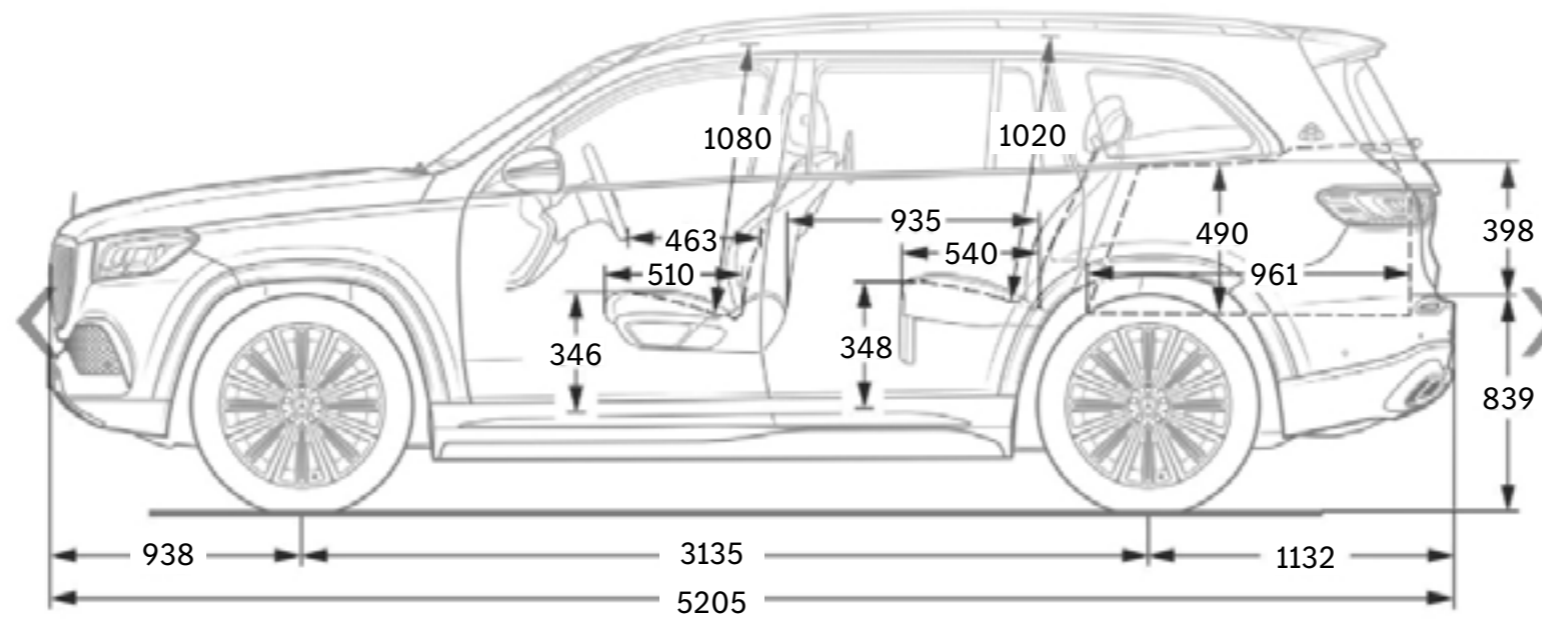



Mercedes-Benz Services

Advance Assurance Program

Extending your warranty coverage

With Advance Assurance Program, experience complete peace of mind. While this Extended Warranty Program kicks in the moment your standard 3 years warranty comes to an end, it can be extended further up to 6 years at a nominal price. Also, it comes with a bouquet of privileges for a worry-free time with your Star.

Star Ease

Delivering the best-in-class value

Servicing your Star does not get any better than this. With the STAR Ease Maintenance Packages, pay a defined cost of maintenance based on the model, contract period and mileage and say goodbye to spending on service every time. Plus, enjoy exclusive features like priority handling, shorter waiting time and quicker processes.

Mercedes-Benz Services

Mobilo

Providing you 24x7 mobility support

Your vehicle comes with Mobilo which provides round-the-clock on-road assistance service. Mobilo comes as a standard for 3 years and can be extended further up to 8 years at a nominal cost. This service offers privileges like vehicle towing facility, replacement vehicle, hotel accommodation, just to name a few.

Digital Service Drive

Ensuring convenience and transparency of service.

Servicing your Star is the last thing you will ever have to worry about. We provide transparent, convenient and hassle-free service. Our customer-friendly service features work around your busy schedule so that you have one less thing to focus upon.





Mercedes-Benz Services

Mercedes-Benz Genuine Parts**

Now with 2 years of warranty

Mercedes-Benz Genuine Parts are crafted to the state-of-the-art standards of Mercedes-Benz, protecting your vehicle's performance while maintaining the style, comfort and safety, for the years to come. Also, they come with a warranty of up to 2 years, ensuring you a peaceful ownership experience with your Star.

**Terms and Conditions apply.

Premier Express Prime*

Because we value your time as much as you do

Life gets busy and so we have designed Premier Express, our vehicle care service to help you get in and out quickly. While the visit will be brief, the service offered by our technicians will be comprehensive and complete. All to ensure your Mercedes-Benz is running for miles to come.

*Available at selected locations and will be expanded to more locations.

Mercedes-Benz Services

Mercedes-Benz Approved Tyres and Alloys

Ensuring every ride is a safe and joyful one

Maximise the safety and comfort of your Star with Mercedes-Benz approved tyres and rims. While the Mercedes-Benz approved tyres are designed to optimally match your car's performance, the Mercedes-Benz approved rims are designed to lend an exceptional style to the exterior of your Star and are also engineered for optimal performance.

Mercedes-Benz Genuine Chemical Products

Because your Star deserves nothing but the original

Mercedes-Benz Genuine Chemical Products are specially tested for compatibility with the materials in our cars and meet the high quality standards. Also, our products have been approved under Mercedes-Benz Group AG's strict, self-imposed environmental norms. Now with Mercedes-Benz Genuine Chemical Products, experience a whole new world of superior products that support throughout the car's life cycle.





Mercedes-Benz India Private Limited: E-3, MIDC Chakan - Phase III, Chakan Industrial Area, Kuruli & Nighoje, Tal: Khed, Pune - 410 501 (India) Toll free No.: 0008000501888. e-mail: cs.ind@cac.mercedes-benz.com, website: www.mercedes-benz.co.in Please note: This brochure is intended for general information, description and illustration of the Product including optional functions and equipment and may not be specific to a Product since specification of a product may change from time to time. Optional features, functions and equipment etc. may not be present in the Standard or Variant Product or Special Edition Product. Further, Standard specifications of a product may also vary from time to time. Colours may differ from those shown in pictures in the brochure. Mercedes-Benz India reserves the right to make changes without prior notice, in design, colours, materials, components, equipment, specifications, features, functions, make and models etc. The information given in this brochure shall be regarded as accurate at the time of launch and may vary thereafter due to any developments or any other reason. Interested customers should reach out to the Authorised Franchise Partner for further information on the exact specifications, features of the product.

Images shown are for representation purposes only. Some of the vehicles in the Brochure are left hand drive wheel. However, Mercedes-Benz India only manufactures and sells vehicles as per the applicable motor vehicle regulations in India. All vehicles sold by Mercedes-Benz Authorized Franchise Partners shall be with right hand drive wheels only. All title, ownership rights and intellectual property rights in and relating to this brochure/magazine or publication material or any copies thereof including but not limited to copyright, logos, names, trademarks, service marks, design, text, images, links, concepts and themes are owned by Mercedes-Benz Group AG and/or its subsidiaries collectively or used under authorised license by the Mercedes-Benz Group AG. Any reproduction, transmission, publication, performance, broadcast, alteration, license, creation of derivative works or other use in whole or in part in any manner without the prior written consent of Mercedes-Benz India Pvt. Ltd is strictly prohibited. Please note that certain services are offered free of cost for a period of three (03) years and may be chargeable at the expiry of three (03) years from the date of activation of such services. If you wish to continue using those services, you may renew the same through Mercedes Me Store (as and when it is available). Please get in touch with your preferred Franchise Partner for more details. Mercedes-Benz cars: The Maybach GLS 600 meets Bharat Stage VI equivalent emission norms. CIN - U34102PN1994PTC083160