



# RS 5

 Audi RS5 Coupé

 Audi Sport  
performance cars







	Page	
Fascination		
	4	Audi RS 5 Coupé
Technology		
	26	Audi efficiency
	28	Audi ultra
	30	V8 FSI engine
	32	S tronic®
	34	quattro®
	36	Suspensions
	38	Brake systems
	40	Audi drive select
Equipment		
	44	Paint finishes
	46	Wheels/tyres
	48	Seats/seat upholstery
	50	Inlays
	51	Lights and mirrors
	51	Exterior equipment
	52	Interior equipment
	53	Infotainment
	53	Assistance systems
	54	Technology
Other		
	55	Technical data
	56	Dimensions



 A coupé like it should be.

Speed is a challenge. Combining speed and beauty is an art. Here is our result: the Audi RS 5 Coupé. Under its exciting exterior beats the heart of a top athlete. Inspiring performance and fascinating technologies make it an extraordinary vehicle. An attraction even at a standstill, it is an experience in motion. A coupé like it should be. The Audi RS 5.

# Only faster.





 An athletic sight. A powerful engine. The

# RS 5.







The high-speed 4.2 litre V8 FSI engine gives the Audi RS 5 Coupé athletic attributes: spontaneous responsiveness, enormous sprinting ability and outstanding elasticity. In addition, it also releases extraordinary acceleration forces which let the RS 5 spurt from 0 to 100 km/h in only 4.5 seconds.



With this power pack it effortlessly achieves its top speed of 250 km/h\*. The RS 5 will not only leave you enthralled by its enormous propulsion, but by its driving dynamics and performance in the whole speed range.

\*Electronically regulated.







# Power

can take on different shapes. You can see one of the most beautiful here.







Every detail underlines the dynamics of the RS 5 – and characterises it immediately as a typical Audi RS model. The rear convinces with clear lines which the striking bumper with integrated diffuser insert and the large oval tailpipes harmoniously blend into. An attraction not just for the eyes but also for the ears is the optional sports exhaust system with black tailpipe trims. It makes the Audi RS 5 Coupé sound even sportier. The characteristic spoiler rounds off the impression, extending from the luggage compartment lid automatically at speeds of over 120 km/h to increase downforce.







The front end is clearly recognisable as an Audi RS model thanks to the matt aluminium-look Audi Singleframe. The radiator grille with honeycomb grid design has a metallic polished surface in anthracite. Another feature at the front: the large air inlets which guarantee the cooling air supply and the size of which is a good indication of the power behind them. As an optical contrast, the slim xenon plus headlights with their characteristic LED daytime running light strip gleam alongside the Singleframe. And if this front is not exciting enough for you, you can give it your own quite personal touch by ordering the optional style packages in black or matt aluminium.





Accentuated wheel arches and sill extensions define the powerful side line. Behind the large forged aluminium wheels in the attractive 10-spoke design, the high-performance brake system with high-gloss black callipers and wave brake discs can clearly be seen. The clearly defined trailing edge on the vehicle rear completes the sporty appearance.







Every detail is sporty,  
the craftsmanship masterly. Perceptible

**precision.**

The first impression of the interior: clear design. High-quality materials. Professional workmanship. A successful interface between vehicle and driver, created for your individual driving style. The moulded S sports seats with upholstery in an Alcantara/leather combination or fine Nappa leather hold you extremely well. Matching the seats, inlays in matt brushed aluminium or, on request, carbon, in piano finish, black, aluminium race,

matt brushed aluminium or stainless steel mesh guarantee an exclusive overall impression. This impression is rounded off by the sporty controls such as the flat-bottomed RS 5 leather-covered multifunction sports steering wheel, the RS 5 selector lever knob and the pedals in aluminium look. Everything has a functional design – yet the atmosphere is electric!





■ Your quite personal Audi RS 5 Coupé: full of character and an

# individual.

Give your RS 5 its quite individual character: with the Audi exclusive customising range you can extend the already wide range of standard design possibilities even further. The range includes numerous leather colours and special inlays. Whatever you want to make out of your RS 5— we will help you to do it.







The ride is over. What remains is

# enthusiasm.





## Your Audi also bears our mark of special efficiency.

Breathtaking sportiness is not only based on power but on efficiency too. Which is why we have equipped the Audi RS 5 Coupé with numerous progressive technologies.

One example: the engine. Since heat is drawn from the combustion chambers by FSI® direct fuel injection, higher compression ratios can be achieved. The result is more output and torque with lower fuel consumption.

The 7-speed dual-clutch transmission S tronic ideally exploits the advantages of the high-torque V8 engine: the large transmission-ratio

spread allows both a sporty short ratio for the first gear as well as an engine speed-reducing long phase for the last gear to save fuel.

The standard electromechanical power steering guarantees even more efficiency. In addition to the speed-dependent steering support it provides, the advantage is that it uses almost no energy when driving in a straight line.

The recuperation system, which is also fitted as standard, recovers energy during coasting and braking phases by means of intelligent alternator voltage regulation, and then

temporarily stores this energy in the battery. When the vehicle accelerates again, the energy flows back into the vehicle electric system, taking the strain off the alternator and thus saving fuel.

You see, the Audi RS 5 Coupé features a whole range of technologies that will make your journey not only more dynamic but more efficient, too. Find out more on the next few pages.





Audi ultra on the podium: the Audi R18 TDI

# Audi ultra:

## Every gram less extends the lead.

Audi ultra, the pioneering lightweight technology from Audi, is more than just the sum of its individual components. It combines innovative materials, intelligent design principles and production processes that use resources sparingly into an overall concept. Many Audi ultra lightweight measures have already been implemented in the Audi RS 5 Coupé.

This starts with the body itself. The steel shell design of the Audi RS 5 combines low weight with high rigidity. The tailor-made floor pan is made using different material thicknesses and

qualities. The design uses only as much material as necessary in the respectively right places to achieve the best result.

Thin metal panels made of hot-formed and cold-formed steel make up the body. The front wings of the Audi RS 5 Coupé are made of aluminium and help to improve the axle load distribution. The aluminium components on the front and rear axles as well as the lightweight forged aluminium wheels consistently implement this lightweight theme. New innovative wave brake discs with a wave-shaped

contour and aluminium brake disc chambers specifically reduce the weight on the wheels. The resulting reduction in unsprung masses leads to improved rolling characteristics.

The self-locking crown gear centre differential is smaller and lighter than the previous version used. Yet another convincing example of Audi ultra.

Each lightweight component has an effect on other components, allowing their dimensions to be reduced as well. The result is a continuous

development process towards less and less weight and more and more efficiency. In figures: a vehicle that weighs 100 kg less can save up to 0.3 litres of fuel per 100 km.

About weight reduction

**The demands placed on modern vehicles are contradictory.** On the one hand, they must offer enhanced performance and comfort, on the other they need to be more economical and efficient. Audi ultra resolves this conflict by examining each and every component. We demand the highest functionality combined with the lowest possible weight. The result is an intelligent mix of materials that even allows a reduction in engine size: lighter vehicles no longer need a large engine to be agile. In 2011, for example, the R18 TDI won in Le Mans with a V6 engine, whereas its victorious predecessor, the R15 TDI, had featured a V10 engine.







#### V8 engine with 4,163 cm<sup>3</sup> of displacement

- Maximum power output 331 kW at 8,250 rpm
- Maximum torque 430 Nm at 4,000 – 6,000 rpm
- Specific power output 79.5 kW/l of displacement
- High-rev concept (HRC) up to max. 8,500 rpm
- FSI direct fuel injection with up to 120 bar



#### The high-rev concept (HRC) in brief:

The agile and free-revving engine has an extremely large speed range, accentuated by impressive engine acoustics. It stands out through a high power yield and even power delivery.

What is the quickest way to say performance?

# HRC.

You feel the power under the bonnet of the Audi RS 5 Coupé as soon as you start the ignition. It is generated by the 4.2 litre V8 FSI® engine: this has FSI® direct fuel injection technology, which we brought from the racing track to the road, and works with our tried-and-trusted high-rev concept (HRC).

FSI technology directly injects the fuel into the combustion chamber where it is highly compressed. This produces a very even fuel/air mixture, leading to particularly efficient combustion and therefore to better power

delivery and power yield. In addition, the direct injection serves to cool the inside of the combustion chambers so that engine compression can be increased. This results in advantages for both power output and torque.

Another component for the irresistible power of the RS 5: the high-rev concept (HRC). It provides you with high power yield per litre of displacement coupled with even power delivery over the whole engine speed range. The extremely agile and free-revving engine reacts immediately and also produces a rich and full sound.

Engine power curve V8 FSI

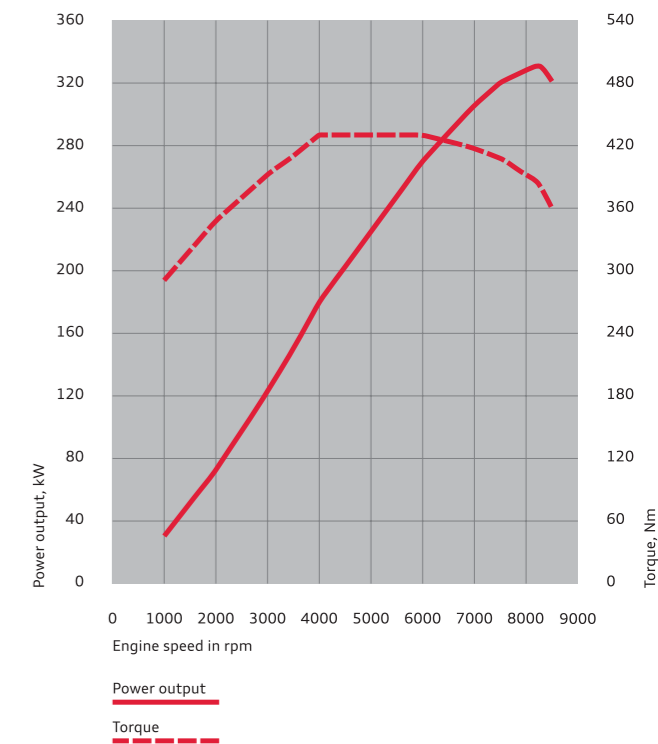

The high-power engine in the Audi RS 5 Coupé permits engine speed ranges of up to 8,500 rpm. It reaches its maximum torque of 430 Nm at engine speeds of between 4,000 and 6,000 rpm, with at least 90% of the power available in a wide engine speed range of between 3,000 and 8,000 rpm. This lets the RS 5 sprint from 0 to 100 km/h in only 4.5 seconds – and then ease to the 200 km/h mark in a further 10.9 seconds.



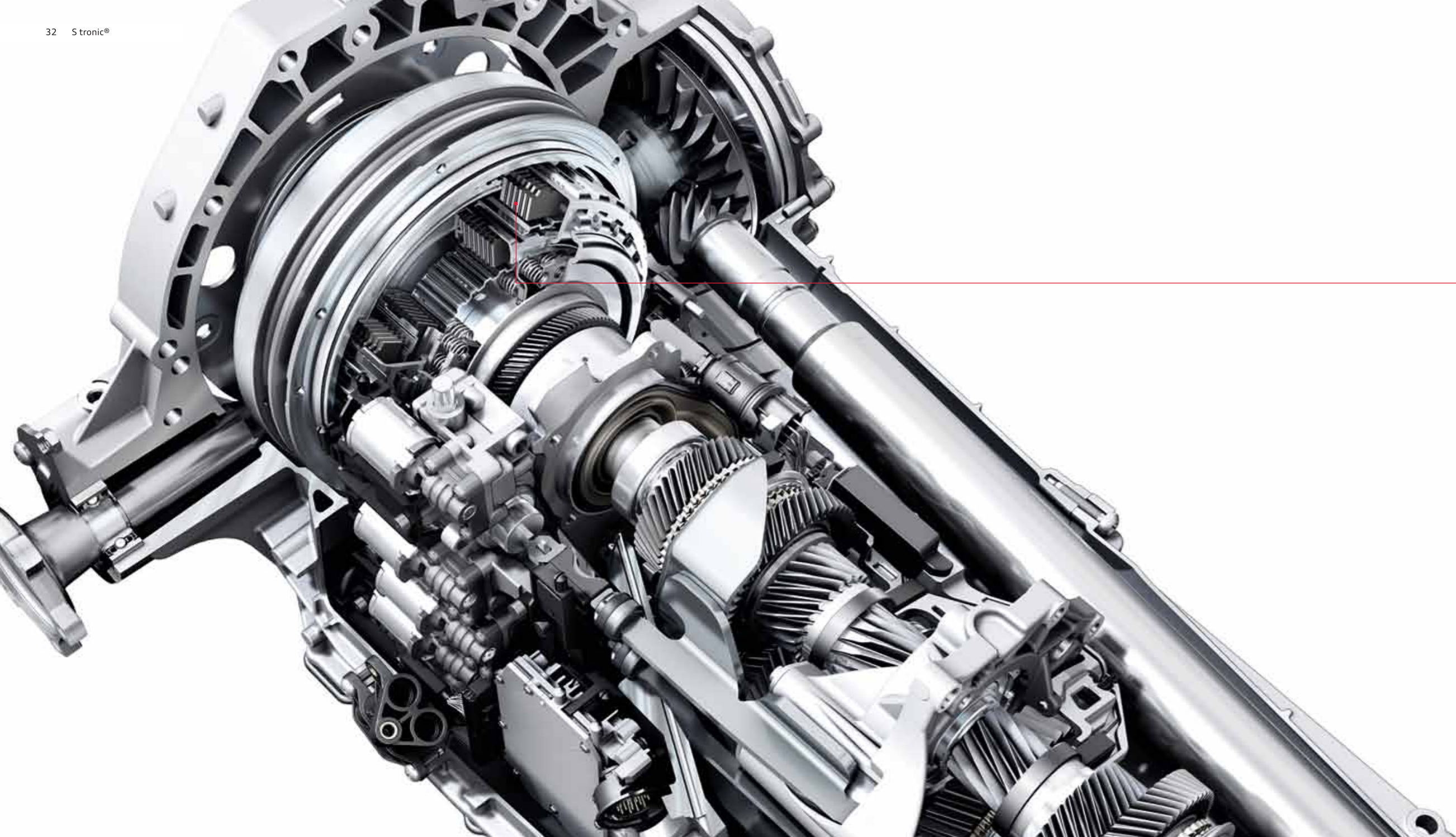

## What is the benefit of two clutches?

A double saving: time and energy.

A high-performance engine needs an adequate transmission. Which is why the Audi RS 5 Coupé has a dual-clutch transmission that stands out through fast gearchanging and a high degree of efficiency.

The 7-speed S tronic comprises two multi-plate clutches and two transmission parts. These are both permanently active, but only one of them is actually connected to the engine. For example, when the driver accelerates in third gear, the second part of the transmission is already set in

fourth gear. The gear change happens through the change of clutches – the first clutch opens whilst the second one closes. The gear change only lasts a few hundredths of a second and is completed with almost no interruption in the power flow. So quickly and smoothly that it is hardly perceptible. You can choose whether you want to change gear yourself or leave it up to the transmission. In manual mode, you influence the gearchange via shift paddles on the steering wheel or by briefly touching the selector lever. In automatic mode, you can change the gearshift

characteristics by selecting the programs D (Drive) and S (Sport) or through Audi drive select.

Even with all of this dynamic technology, however, the S tronic still remains very efficient. Its high level of efficiency contributes to reducing both fuel consumption and emissions. In addition, the seventh gear with long transmission ratio has been designed as overdrive.



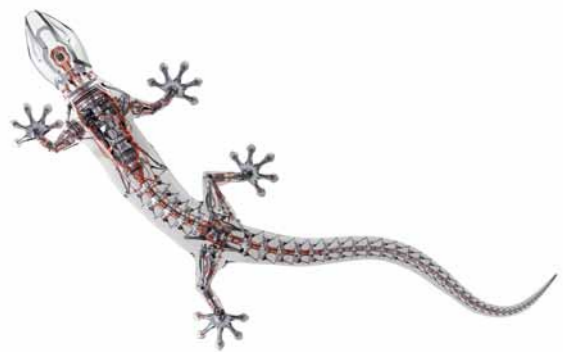

# Why only use two wheels when a car has four?

## The quattro® permanent all-wheel drive.

Those who know Audi know quattro®. And once you have driven with the permanent all-wheel drive from Audi, you do not want to drive with anything else. Why? Because there is hardly another drive system around that transfers the engine's power to the road so directly.

The latest generation of permanent all-wheel drive quattro is used in the Audi RS 5 Coupé. Its main component is the self-locking crown gear centre differential that has disc sets to achieve high blocking factors for even better traction.

It is also lighter and more compact than the previous design. The asymmetrical basic design of the torque distribution of 40:60 (front axle: rear axle) is retained for the benefit of the driving dynamics; but now a greater share of the torque can be directed to the front or rear axle if required.

In conjunction with the wheel-selective torque control, the drive force is distributed to each individual wheel depending on the driving situation. The special feature here is that the

effect of torque distribution is felt before undesirable wheel slip occurs. This allows a resulting yaw moment to be produced which supports cornering.

The overall result is precisely controllable and sporty vehicle handling as well as increased agility coupled with outstanding traction

The quattro drivetrain with wheel-selective torque control can be supplemented by the sports differential on the rear axle on request.

**The crown gear centre differential** has disc sets to achieve higher blocking factors. This allows up to 85% of the drive torque to be distributed to the rear axle and up to 70% to the front axle.

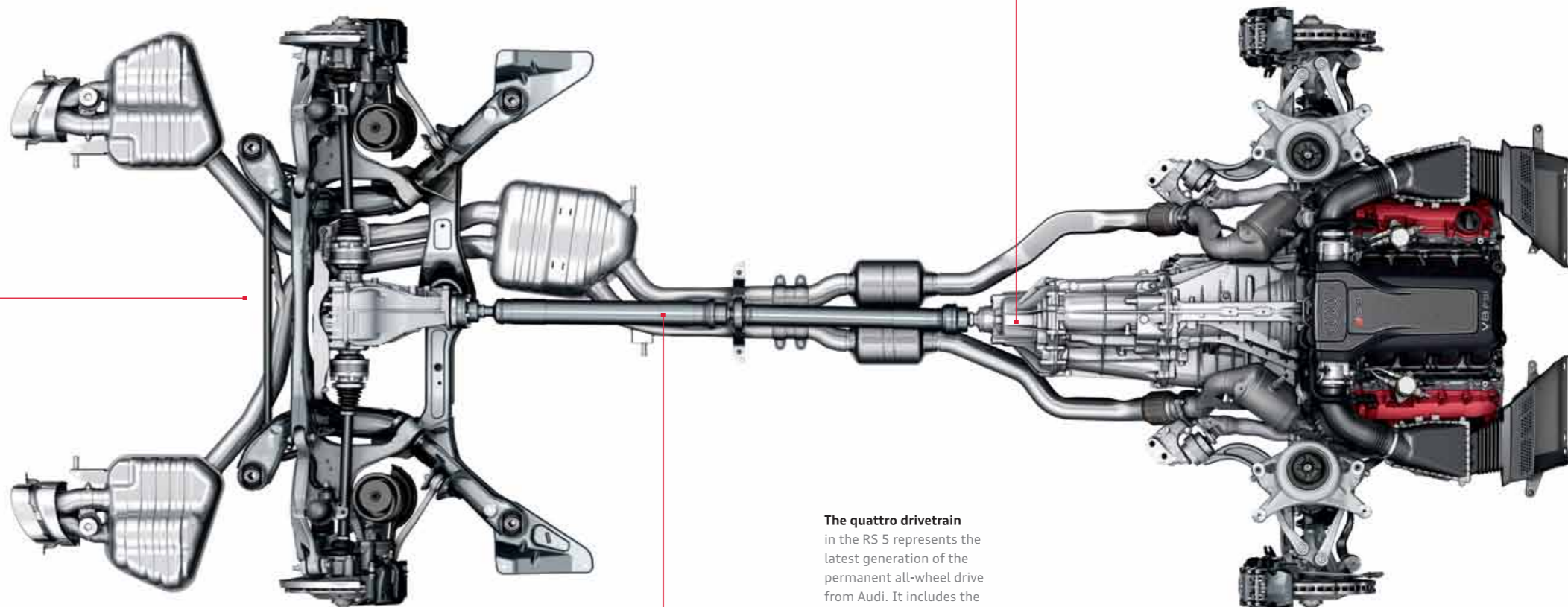

**The quattro drivetrain** in the RS 5 represents the latest generation of the permanent all-wheel drive from Audi. It includes the self-locking crown gear centre differential and has wheel-selective torque control.



# Superb driving performance can be learnt.

## From its suspension, for instance.

Whether on long journeys or quick trips: the RS 5 sports suspension gives the Audi RS 5 Coupé excellent road handling which gives you poise. It combines precise steering characteristics, outstanding grip and high agility.

The front axle is designed as a 5-link design. The links are connected on a front axle bearer made of aluminium which is bolted to the body for reasons of rigidity. This makes precise wheel guidance possible, while the virtual steering axle allows for an extremely short lever, thus reducing influences through drive and interference forces.

The rear axle construction is a trapezoid-link rear suspension with independent wheel

suspension, the axle carrier of which is flexibly mounted. All the important elements of the RS 5 sports suspension are made of aluminium to keep the unsprung masses low. This allows sporty handling and improved rolling characteristics to be achieved.

The sports suspension plus with Dynamic Ride Control (DRC) is available as an option for the RS 5. With this suspension technology, the nodding and pitching movements of the vehicle around the lateral and longitudinal axes are reduced purely hydraulically. The diagonal dampers are connected to one another via oil pipes and one central valve each. If the dampers are immersed differently, for example during fast cornering, the valves affect the oil flow at the

cushioned wheel. They increase support there, thus reducing side tilt and increasing driving dynamics.

The sports suspension plus with Dynamic Ride Control (DRC) can be adjusted in three stages via Audi drive select: in the comfort mode it guarantees smooth rolling behaviour, the auto setting supports a committed driving style and in the dynamic position it delivers maximum driving precision.

In order to do justice to the dynamic requirements made on a high-performance vehicle, the characteristic curves of the springs and dampers as well as the rigidity of the tubular stabilisers were developed and put through their paces during extensive test series, including on

racing tracks. Equally, the electromechanical power steering was given a specific characteristic curve as part of its adaptation to the Audi RS 5 Coupé. It works speed-dependent with variable steering support. Thanks to the low-positioned arrangement, the steering forces are conducted just a short distance to the wheels, which provides for a spontaneous steering response and gives you precise feedback from the road. Since the steering requires almost no energy when driving in a straight line, it also helps to reduce fuel consumption.

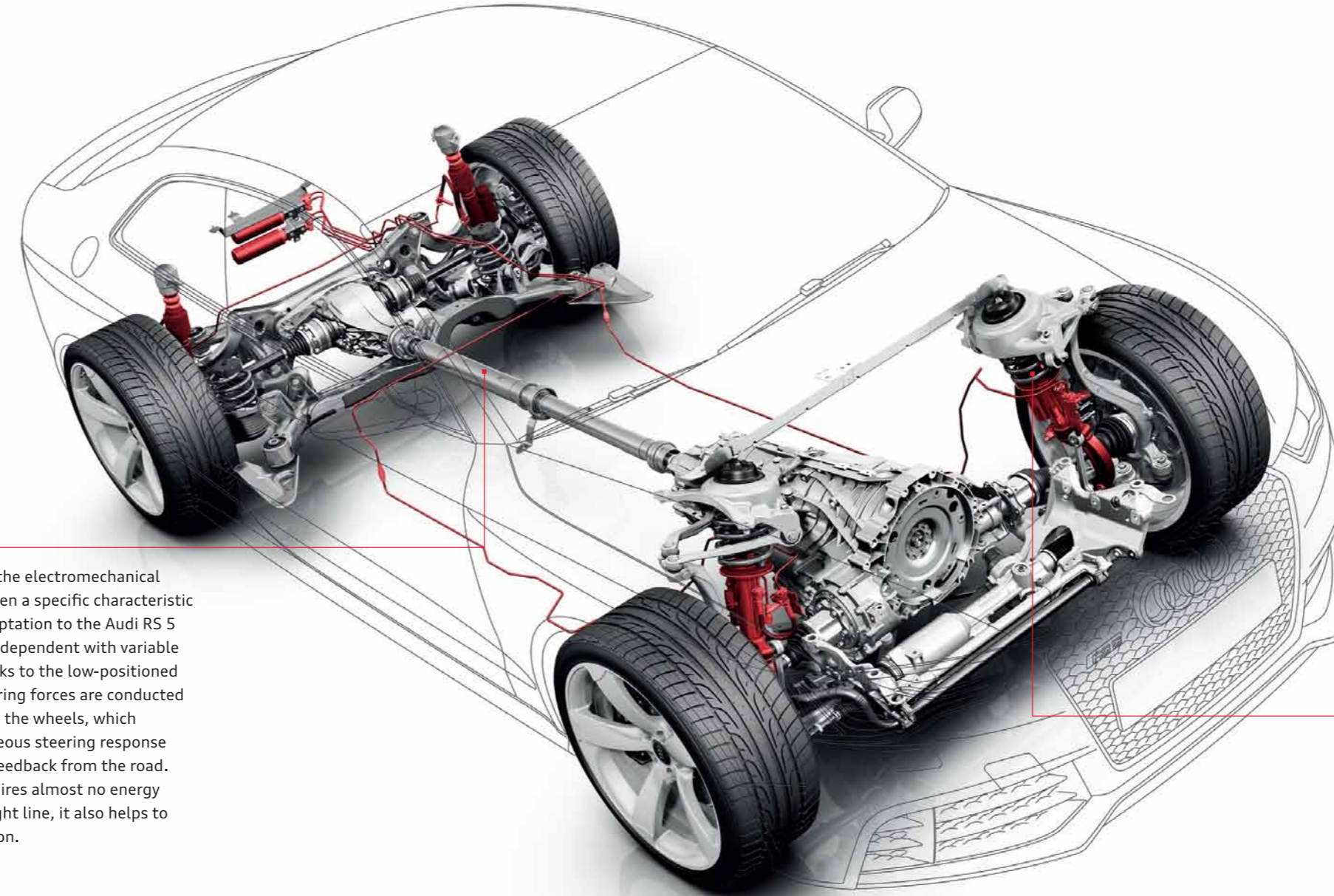

**The sports suspension plus with Dynamic Ride Control (DRC)** is based on the RS 5 sports suspension. Thanks to the hydraulic links between the diagonal shock absorbers, the nodding and pitching movements of the vehicle are reduced, leading to an increase in driving dynamics. The damper recognition can be varied in 3 stages via Audi drive select: comfort, auto, dynamic.



# Nothing can stop a top athlete.

Except for a top brake system.



The standard 18-inch high-performance brake system takes a powerful hold with its 8-piston fixed callipers on the front axle. A single-piston floating calliper is used on the rear axle. The wave brake discs comprise a cast friction ring with a wave-shaped outer contour which is connected to the brake disc chamber by means of aluminium pins. This so-called floating mounting ensures that the friction ring remains tension-free to a major extent, improving stability under high temperature loads. In addition, the axial perforation and cooling channels for internal ventilation increase the brake discs' performance. The use of aluminium and the characteristic geometry of the friction rings reduce the weight of the brake discs, thus improving the balance of the unsprung masses.

18-inch high-performance  
brake system

The brake discs on the front axle have a diameter of 365 mm and a wave-shaped outer contour. The brake callipers are painted high-gloss black.





Why does the Audi RS 5 Coupé suit you so well?  
Because it adapts itself to you so well.

Audi drive select.



comfort



dynamic



auto



individual

With the standard Audi drive select you can influence individual vehicle components at the push of a button. Generally speaking, the accelerator pedal characteristic curve, exhaust flap control, gear mode and steering torque of the electromechanical power steering can be configured. You have three modes available to adapt these components to the individual driving situation. auto mode is the setting that defines the sporty supremacy of the Audi RS 5 Coupé. comfort mode is particularly suitable for long drives, whereas dynamic mode has been

designed for ambitious driving. In conjunction with the optional MMI® navigation system, you also have the individual mode available, which you can use to configure the individual components yourself.

In addition, various optional systems can be influenced. For example, the sports suspension plus with Dynamic Ride Control (DRC) – the characteristic curves of the shock absorbers can be varied in three stages: from gentle rolling in comfort mode through to a sporty-direct reaction in the dynamic position.

- variable gearshift characteristics
- variable acceleration pedal characteristic curve
- variable steering torque
- exhaust flap control
- quattro with sports differential
- dynamic steering
- sports suspension plus with Dynamic Ride Control (DRC)



The optional dynamic steering allows the steering ratio and support to be changed depending on driving speed and the Audi drive select mode selected.

In conjunction with the equipment version quattro with sports differential, an additional infinitely variable distribution of the driving power between the rear wheels takes place, not only during acceleration but also during overrun or coasting. This torque manipulation specifically influences the vehicle's steering behaviour and

increases agility even further, depending on the selected Audi drive select setting made.





It is the equipment that turns an Audi into your Audi.





Daytona grey, pearl effect

Solid/metallic paint finishes



Ibis white



Suzuka grey, metallic

Pearl effect paint finishes



Misano red, pearl effect



Daytona grey, pearl effect



Sepang blue, pearl effect



Phantom black, pearl effect

Crystal effect paint finishes



Prisma silver, crystal effect



Panther black, crystal effect

Audi exclusive customised paint finishes



Audi exclusive customised paint finishes\*





Cast aluminium wheels in 5-arm rotor design in titanium look, high-gloss turned finish\*

\*Optional

Wheels/tyres



Forged aluminium wheels  
in 10-spoke design, high-gloss turned finish  
size 9 J x 19 with 265/35 R 19 tyres



Cast aluminium wheels\*  
in 5-V-spoke design in titanium look,  
high-gloss turned finish  
size 9 J x 20 with 275/30 R 20 tyres

\*Optional



Cast aluminium wheels\*  
in 5-arm rotor design  
size 9 J x 20 with 275/30 R 20 tyres



Cast aluminium wheels\*  
in 5-arm rotor design in titanium look,  
high-gloss turned finish  
size 9 J x 20 with 275/30 R 20 tyres

**Anti-theft wheel bolts**  
can only be loosened with the supplied adapter

**Tyre repair kit**  
with 12V compressor and tyre sealant; permissible top  
speed 80 km/h

**Tyre pressure loss indicator\***  
visual and acoustic warning if the pressure drops in one  
or more tyres; display in the driver information system

**Vehicle tool kit\***  
in the luggage compartment

**Vehicle jack**  
in the luggage compartment





#### S sports seats, front

with shaped side bolsters for better lateral support, integrated head restraints and RS 5 embossing on the front-seat backrests; electric seat height, fore/aft position, seat and backrest angle adjustment; electric 4-way lumbar support; extendable thigh support; convenience entry; rear seat bench with integrated centre storage tray. (The image shows S sports seat, front, in fine Nappa leather, black with piping in rock grey).

\*Optional

#### Leather upholstery and trim

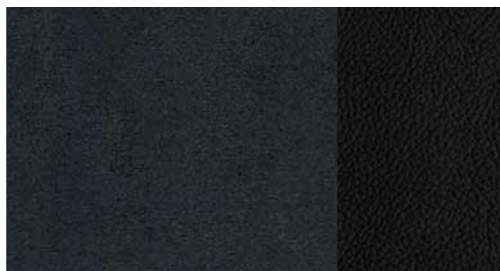

Alcantara/leather, black\*



Audi exclusive leather upholstery and trim\*



Fine Nappa leather, black  
with piping in rock grey



Fine Nappa leather, lunar silver  
with piping in rock grey

#### Leather upholstery and trim

##### Alcantara/leather combination\*

seat centre sections, door and side panel inserts in Alcantara, seat side bolsters, head restraints and front centre armrest in leather; RS 5 embossing on the front-seat backrests

##### Fine Nappa leather with piping

seat upholstery with piping in rock grey; head restraints, door and side panel inserts as well as front centre armrest in fine Nappa leather; RS 5 embossing on the front-seat backrests; including leather-covered armrests in the door and side panel trims.

##### Leather-covered armrests in the door trims

and side panel trims in fine Nappa leather

##### Audi exclusive design package in Valcona leather with diamond-patterned stitching\*

seat upholstery, head restraints, door and side panel inserts, front centre armrest as well as armrests in the door and side panel trims in black leather with crimson red stitching; inserts of the front seat side bolsters and centre panels with diamond-stitching in crimson red; RS 5 embossing on the front-seat backrests; including floor mats in black with leather piping in crimson red and controls with crimson red stitching

##### Audi exclusive leather upholstery and trim (package 1)\* in Valcona leather with diamond-patterned stitching

seat upholstery, head restraints, door and side panel inserts, front centre armrest as well as armrests in the door and side panel trims in leather; inserts of the front seat side bolsters and centre sections with diamond-stitching; RS 5 embossing on the front-seat backrests; individual choice of colour for leather and decorative stitching from the range of Audi exclusive colours.

\*Optional

##### Audi exclusive leather upholstery and trim (package 1)\* in Alcantara/leather combination

seat centre sections, door and side panel inserts in Alcantara, seat side bolsters, head restraints, front centre armrest as well as armrests in the door and side panel trims in leather; RS 5 embossing on the front-seat backrests. Individual choice of colour for the Alcantara, leather and the decorative stitching from the range of Audi exclusive colours

##### Audi exclusive leather upholstery and trim (package 1)\* in Valcona leather

seat upholstery, head restraints, door and side panel inserts, front centre armrest as well as armrests in the door and side panel trims in leather; RS 5 embossing on the front-seat backrests (with S sports seats, front, and RS 5 bucket seats, front). Individual choice of colour for the leather and the decorative stitching or piping from the range of Audi exclusive colours

##### Audi exclusive leather upholstery and trim (package 2)\* in Valcona leather

in addition to package 1: backrest covers leather-covered and seat attachments matched to the leather colour. Individual choice of colour for the leather and the decorative stitching or piping from the range of Audi exclusive colours



**Inlays**

for front door trims and rear side panel trims and in the centre console



Stainless steel mesh\*

**Inlays**

Carbon\*

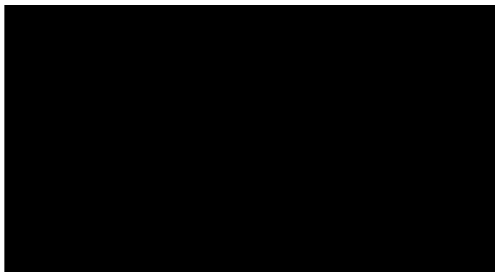

Piano finish, black\*



Aluminium race\*

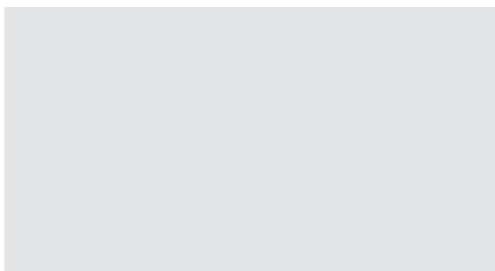

Stainless steel mesh\*

(centre console in piano finish, black)



Matt brushed aluminium

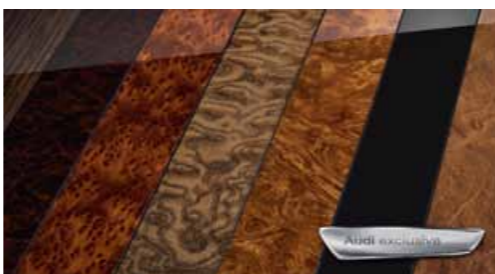

Audi exclusive inlays\*

in a choice of different types of wood or painted in body colour

**Lights****Xenon plus including headlight cleaning system**

The headlights with durable gas discharge technology for dipped and high beam enable an intensive illumination of the road with evenness and range, in a colour resembling daylight both close-up and in the distance. The automatic dynamic headlight beam control prevents oncoming traffic from being dazzled; daytime running light strip and rear lights in LED technology with low power consumption

**Daytime running lights**

Homogeneous daytime running light strip in LED technology with low power consumption, integrated into headlights

**Adaptive light\***

The dynamic cornering light identifies the course of the road from the movement of the steering wheel. The headlights swivel – depending on the steering angle – towards the curve and in this way variably illuminate the course of the curve. The adaptive light is operational between speeds of approx. 10 km/h and 110 km/h.

Includes turning light, which switches on automatically if the indicators have been engaged for some time and illuminates the new direction of travel

**High-beam assist\***

working within system limits, it automatically detects the headlights of oncoming traffic, the rear lights of other road users and built-up areas. Depending on the traffic situation, the high beam is automatically switched on or off. The system thereby improves the driver's visibility and ensures a more relaxed drive thanks to the extra comfort and convenience

**Lighting package**

includes rear reading lights, illuminated vent controls and inside door handles, active door reflectors, entrance lighting, footwell lights front and rear, illuminated glove compartment

**LED rear lights**

brake/rear, rear fog, indicators and rear number plate lights in LED technology; reversing lights have light bulbs

**Light/rain sensor**

for controlling the automatic headlights, the coming home/leaving home function and the automatic wiper function, includes windscreen with grey strip along the top edge

**Mirrors****Exterior mirrors with integrated LED indicator**

electrically folding, automatically dimming with memory function including automatic kerb-side function for the exterior mirror on the passenger side

The automatic kerb-side function tilts the exterior mirror on the passenger side downwards when reverse gear is engaged, giving the driver a better view of the kerb

**Exterior mirror housings**

in matt aluminium look

**Interior mirror automatically dimming**

includes light/rain sensor; windscreen with acoustic glazing, as a result improved insulating value of the windscreen and reduced noise level from the outside

**Roof system****Panoramic tilt sunroof\***

electrically operated, made from tinted single-glazed safety glass with manually adjustable sunscreen, convenience locking/opening from outside via the central locking and the radio-operated remote control

**Closing systems****Central locking**

with autolock function, radio-operated remote control integrated in the vehicle key and variable code; with one touch of the button the system opens and locks doors, luggage compartment lid and tank flap; includes convenient closing/opening of the windows and separate luggage compartment lid unlocking function via the radio-operated remote control; additional activation from inside on the driver's door; radio-operated key with RS emblem

**Comfort key\***

access and drive authorisation system; the key only needs to be carried with you; the engine is started and switched off via the engine start-stop button on the centre console, the vehicle is locked from outside via buttons on all door handles. The vehicle can also be opened from the luggage compartment lid

**Electronic immobiliser**

integrated in the engine control unit, automatically activated by the vehicle key

**Luggage compartment lid, automatically opening**

When the luggage compartment is released by the radio-operated remote control, the button in the door or by the soft-touch release on the luggage compartment lid, the luggage compartment lid automatically swings open

**Anti-theft alarm**

including interior monitoring system and tow-away protection via angle of inclination sensor; can be deactivated; signal horn for monitoring the doors, bonnet and luggage compartment lid independent of vehicle electrical system

**Glazing****Heat-insulating glass**

green tinted, windscreen made of laminated glass

**Windscreen cleaning system**

2-speed operation, 4-speed adjustable intermittent wipe, flick-wipe function, automatic wash/wipe function

**Sunblind**

electric, for the rear window

**Further exterior equipment****Trim strips**

in matt aluminium look

**Audi exclusive black styling package\***

radiator grille frame, radiator grille, front number plate holder and blade in the front bumper in high-gloss black; trim strips on the window slot and roof frame in matt black

**Bumpers**

in a sporty dynamic design; at the front with large air inlets in high-gloss black and blade in matt aluminium look, at the rear with diffuser insert in matt black

**Audi Singleframe**

radiator grille with honeycomb-design grille in high-gloss anthracite and one-piece trim frame in a matt aluminium look

**Exhaust system**

dual-branch design with oval tailpipe trims in aluminium look



<b>Sports exhaust system*</b>
dual-branch design with oval tailpipe trims in high-gloss black; for an increased sound experience

<b>Rear spoiler</b>
integrated in the luggage compartment lid; extends electrically depending on vehicle speed; automatically extends at 120 km/h, retracts at 80 km/h; can also be controlled manually using a button in the centre console

<b>Model name/logo</b>
RS 5 model name on the radiator grille and on the luggage compartment lid

<b>Wheel house extensions</b>
front and rear

<b>Sill extensions</b>
painted in body colour

<b>Carbon design package*</b>
for the engine compartment

<b>Seats/seating comfort</b>
<b>4-way lumbar support</b>
electric, for driver and front-passenger seats, with horizontal and vertical adjustment

<b>Front seats, electrically adjustable</b>
electric adjustment for seat height, fore/aft position, seat and backrest angles, including electric 4-way lumbar support; additional electric head restraint height adjustment for climate-controlled comfort seats, front

<b>Memory function for the driver seat</b>
2 different presets for the electrically adjustable driver seat and exterior mirrors

<b>Folding rear seat backrest</b>
Rear seat backrest can be split and folded 40:60 or completely, with remote backrest release in the luggage compartment; rear seat bench with integrated centre storage tray

<b>Seat heating, front*</b>
heated seat cushions and backrests as well as side bolsters; individually adjustable in several stages for driver and front-passenger seat

<b>Seat heating, front and rear*</b>
equipment as for seat heating, front, additionally also for rear seats

<b>Centre armrest, front</b>
adjustable lengthways and angle; with fold-open storage compartment and two 12V sockets in the centre console

<b>ISOFIX child seat mounting for the rear seats</b>
Standard bracket for the practical fastening of child seats in accordance with ISO standards; compatible child seats can be obtained from your Audi partner

<b>Steering wheels/selector levers/controls</b>
<b>Leather-covered multifunction sports steering* wheel in 3-spoke design, flattened at the bottom</b>
with shift paddles

<b>Audi exclusive leather steering wheel rim*</b>
leather for the steering wheel rim available in all Audi exclusive colours; individual choice of colour for stitching in various Audi exclusive colours with specific Audi exclusive seam detail

<b>Audi exclusive leather controls*</b>
leather for the steering wheel rim, selector lever knob and gaiter available in all Audi exclusive colours; individual choice of colour for stitching in various Audi exclusive colours; stitching on the steering wheel rim with specific Audi exclusive seam detail

<b>Audi exclusive controls in black suede*</b>
leather for the steering wheel rim and selector lever knob in black suede; individual choice of colour for stitching in various Audi exclusive colours; stitching on the steering wheel rim with specific Audi exclusive seam detail

<b>Climate control</b>
------------------------

<b>3-zone deluxe automatic air conditioning</b>
with sunlight-dependent control, electronically controls the air temperature, flow rate and distribution, separate temperature distribution for driver, front-seat passenger and rear compartment, temperature setting and air distribution adjustable left and right in the front, control panel for setting the temperature in the rear compartment in the rear centre console, automatic recirculation mode by means of air quality sensor, front control panel features digital display, includes rain, light and humidity sensor, combined fine-dust filter, indirect ventilation. key-coded settings

<b>Luggage securing and storage systems</b>
<b>Storage package*</b>
includes storage nets on the front-seat backrests, storage compartment under the front seats (if memory function for the driver seat is fitted, only under the front-passenger seat), cup holder in the rear centre armrest and a lock for the glove compartment

<b>Cup holder</b>
in the centre console

<b>Luggage compartment package*</b>
consisting of a combined net in the luggage compartment, fastening hooks, luggage net on the right hand side of the luggage compartment and 12V socket

<b>Further interior equipment</b>
<b>Pedals and footrest in aluminium look</b>

<b>Floor mats, front and rear</b>
in velour carpet, black

<b>Audi exclusive carpet and floor mats*</b>
Individual choice of colour for carpets, floor mats and piping from the range of Audi exclusive colours

<b>Door sill trims</b>
with aluminium insert and RS 5 logo

<b>Headlining in cloth</b>
in black or lunar silver, depending on the colour selected for interior trim

<b>230V socket*</b>
in the centre console in the rear; replaces the 12V socket

<b>Audi exclusive instrument cluster surround*</b>
in piano finish look, black

<b>MMI® and navigation systems</b>
------------------------------------

<b>MMI® navigation plus*</b>
including navigation data (hard drive), high-resolution 7-inch colour display with high-quality map display, navigation-based speed limit display and topographical map colour, display of a lot of sightseeing information and 3D city models, choice of 3 alternative routes provided, scrolling along the route, joystick map manoeuvring function in the control button, spoken TMCpro reports, split-screen route information (manoeuvring points, points of interest on motorways, TMCpro on route), detailed junction map and lane recommendations, dynamic route guidance with TMCpro (where available), voice control system (destination entry by means of whole word input in a sentence), additional arrow display in the driver information system with colour display, 8 passive loudspeakers, total output 80 watts, radio with triple tuner and phase diversity, hard drive can also be used to store music (20 GB), MP3, WMA, AAC and MPEG-4-compatible DVD player can also be used for music and video DVDs, 2 SDHC card readers (for up to 32 GB), AUX-IN connection

<b>Driver information system with colour display</b>
a high-resolution colour display provides you with information from the onboard computer, auto check system, scope of display of the MMI system, brake wear indicator at front, clock and digital speed display; RS 5 menu with oil temperature display and lap timer; the outside temperature display shows an ice crystal at temperatures under +5 <span> </span> °C to warn of possible black ice; including attention assist

<b>Radio and TV systems</b>
<b>Symphony radio</b>
with integrated CD changer for 6 CDs and SDHC memory card reader (up to 32 GB), both with MP3, AAC and WMA-capability, dynamic station list, 30-station memory, FM (VHF) and AM (MW, LW) reception, MMI operating concept, 6.5-inch TFT colour screen, TP memo function, speed-dependent volume control, phase diversity, AUX-IN connection, 8 passive loudspeakers, total output 80 watts

<b>TV reception*</b>
Reception of digitally-broadcast (DVB-T), uncoded television stations (MPEG-2 or MPEG-4 standard), DVB-T audio stations, teletext and Electronic Programme Guide (EPG). External AV-IN connection via adapter cable (available through Audi Genuine Accessories). Please note: TV reception depends on digital network availability; no picture possible when the vehicle is moving

<b>Audi sound system</b>
6-channel amplifier, 10 speakers including centre speaker in the dashboard and subwoofer in the parcel shelf, total output 180 watts

<b>Bang &amp; Olufsen Sound System*</b>
surround sound reproduction via 14 high-performance speakers, 1 centre speaker and 2 midrange speakers in the dashboard; 1 tweeter in each mirror quadrant; 1 woofer in each front door; 2 tweeters and 2 low/midrange units in the rear side trims; 2 surround sound speakers and 1 subwoofer in the parcel shelf, exclusive speaker covers with aluminium trim, dynamic driving noise compensation, 10-channel amplifier, total output 505 watts. The reproduction of 5.1 Surround Sound is possible in conjunction with MMI navigation plus and the integrated DVD drive.

<b>CD changer*</b>
in the glove compartment, for 6 CDs (MP3 and WMA-capable), shock-resistant, easily accessible, without magazine; each CD can be loaded and changed individually. Playback of copy-protected music files (DRM) is not possible.

<b>Audi music interface</b>
for the connection of Apple iPods from generation 4, Apple iPhone (music functionality) as well as USB storage media and MP3 players. The Audi music interface is housed in the glove compartment, operation is via an Audi radio, an MMI navigation system or a RS 5 leather-covered multifunction sports steering wheel. Please note: can only be used in conjunction with a special adapter cable (available from Audi Genuine Accessories). Please contact your Audi partner or visit www.audi.com/mp3 for information on compatible MP3 players. (In conjunction with the Audi music interface, the AUX-IN connection is omitted.)

<b>Adapter cable set for Audi music interface*</b>
consisting of 2 connection cables for the connection of iPod/iPhone or data carrier/media player with USB connection (Type A); further adapter cables available from Audi Genuine Accessories; visit www.audi.com/mp3 for information on compatibility

<b>Adapter cable set plus for Audi music interface*</b>
in addition to the adapter cable set for Audi music interface support for the representation of cover arts

<b>Telephone and communication</b>
<b>Bluetooth interface</b>
Bluetooth-capable mobile phones can be connected to the vehicle via the interface. Hands-free calls are possible in the vehicle via the microphone; visit www.audi.com/bluetooth for information on compatibility

<b>Bluetooth car phone*</b>
Your Bluetooth-capable mobile phone can be conveniently connected to the vehicle's internal GSM module (provided the mobile phone has SIM Access Profile), additional SIM card reader located in the surround of the MMI navigations. Transfer of phone book entries to the vehicle and management of call lists; simple operation using a MMI navigation system, an RS 5 leather-covered multifunction sports steering wheel or the voice control system; for information on compatibility visit www.audi.com/bluetooth

<b>Assistance systems</b>
<b>Hold assist*</b>
holds the vehicle stationary for unlimited periods after stopping, on almost every uphill and downhill gradient. The system is activated by push-button and allows the driver to drive away easily and comfortably without having to operate the electromechanical parking brake

<b>Parking system plus</b>
acoustic and visual park assist system for the front and rear with MMI screen display; measurement is by ultrasonic sensors concealed in the bumpers

<b>Parking system plus with reversing camera*</b>
acoustic and visual parking system for front and rear, image of area behind the vehicle shown on the MMI display, with dynamic display modes showing the calculated path (steer-angle dependent); includes help lines and guidelines and identification of point at which to apply opposite lock when parallel parking, reversing camera integrated discreetly in the handle strip of the luggage compartment lid

<sup>[</sup>\*Optional

<sup>[</sup>\*Optional



**Cruise control** at speeds of 30 km/h and above, the system keeps the set speed constant, provided that engine power and engine braking effect permit it; also features active braking intervention, e.g. when driving downhill; operated via separate steering column stalk; set speed displayed in the driver information system

Suspensions/brakes
--------------------

**Audi drive select** Changes vehicle characteristics by adapting power steering assistance, accelerator and gearshift characteristics as well as exhaust flap control. The system also influences other optional equipment. Available modes: comfort, auto, dynamic and – in conjunction with an MMI navigation system – individual

Electromechanical power steering
Maintenance-free rack & pinion steering with speed -dependent power steering; precise steering feel at high speeds, excellent assistance when parking

**Dynamic steering\*** When changing lanes, parking and cornering, this system improves comfort and handling by dynamically regulating steering according to the driving situation. In addition to adaptation of the steering effort (as with the electromechanical power steering), the steering angle is also adapted (steering ratio). The system is also supported further by vehicle stabilisation through ESC

**RS 5 sports suspension** with dynamically tuned spring/damper combination and adapted elasto-kinematics; 5-link lightweight front axle with virtual steering axle including suspension brace; trapezoidal-link rear axle with independent wheel suspension; tubular stabiliser front and rear; twin-tube gas-filled shock absorbers and coil springs; front axle carrier rigidly fixed to the body, flexibly mounted axle supports at rear

**Sports suspension plus with Dynamic Ride Control (DRC)\*** adjustable in 3 stages; with variable suspension characteristics; 5-link lightweight front axle with virtual steering axle, including suspension brace; trapezoidal-link rear axle with independent wheel suspension; tubular stabiliser front and rear; single-tube gas-filled shock absorbers and coil springs; control range of Dynamic Ride Control (DRC) can be selected in 3 stages via Audi drive select: comfort, auto, dynamic

Brake system
18-inch diagonally-split high-performance brake system, Antilock Brake System (ABS) and Electronic Brake Force Distribution (EBD), Electronic Stabilisation Control (ESC) with brake assist, aluminium tandem brake booster, wave brake discs ventilated at front and rear, perforated and with floating mounting
Brake callipers
painted high-gloss black, front callipers feature RS emblem

**Electromechanical parking brake** includes parking brake function when stationary, drive -off assistance function through automatic release when driving away and emergency braking function whilst driving acting on all 4 wheels

Technology/safety
-------------------

**Body, galvanised** fully-galvanised in areas at risk from corrosion, unitary construction, welded to the floor pan, front and rear areas feature defined crumple zones, aluminium front wings. (12 year warranty against rust perforation)

**Airbags** adaptive front-end collision protection with seat position recognition and full-size airbag for driver and front passenger; side airbags at front (thorax/pelvis airbags, not with RS 5 bucket seats, front); head airbag system

**Head airbag system** unfolds over the entire length of the side windows and protects passengers in the front and rear in the event of side impact

**Integrated head restraint system** In the event of a rear-end collision, the design of the seats stabilises the upper torso and provides better support for the head. This increases the level of protection and reduces the risk of a whiplash injury

**Instrument cluster** with black dials, red needles, and RS 5 logo in the rev counter; automatic ready-check when engine is started; with adjustable lighting, electronic speedometer with odometer and trip odometer, rev counter, radio-controlled clock (GPS clock in conjunction with MMI navigation plus), coolant temperature display and fuel gauge

**Safety steering column** includes a shunt mechanism with damping function to supplement the protection offered by the seat belts and airbags

**Seat belts** automatic 3-point belts for all seats, with belt force limiter, seat belt tensioner and seat belt reminder, front

**Warning triangle** with bracket on the inside of the luggage compartment

**First-aid kit** in the storage compartment in the centre armrest, rear

**Anti-Slip Regulation (ASR)** for good traction, reduces the spinning of the drive wheels

**Electronic Differential Lock (EDL)** On surfaces with varying levels of grip, this start-off assistant automatically brakes the drive wheels on any surface that is too slippery, thereby ensuring smooth, powerful progress; operates at speeds up to approx. 100 km/h.

**Electronic Stabilisation Control (ESC)** with sport mode, can be deactivated in 2 stages; networks the ABS, EBD, ASR and EDL with its own sensors and compares driving data with reference data; provides better stability at all speeds by targeted braking of individual wheels and intervention in the engine management system

**S tronic®** The 7-speed dual-clutch transmission with electro-hydraulic actuation facilitates shorter gearshift times and gearshifting with hardly any perceptible break in propulsive power; can be operated via the shift paddles behind the steering wheel or the selector lever; in automatic mode the driver can choose between 2 programs D (drive) and S (sports), gearshift characteristics can be changed in automatic mode through Audi drive select

**quattro®** permanent all-wheel drive with wheel-selective torque control, self-locking crown gear centre differential; distributes the driving forces depending on the driving situation to each individual wheel for precisely controlled sporty handling

**quattro® with sports differential\*** The electronically controlled sports differential variably distributes driving force to each wheel and ensures outstanding acceleration performance in corners and stabilises the vehicle’s response to load change. It also improves direct steering characteristics and provides more agile handling due to the lower steering effort required

**Recuperation** Increasing the generator voltage converts kinetic energy into usable electrical energy when the vehicle is coasting or braking. This energy is used to assist the generator during subsequent acceleration, saving up to 3% fuel

Model			
Engine type			
Displacement in cc (valves per cylinder)			
Max. output <sup>1</sup> in kW at rpm			
Max. torque in Nm at rpm			
Power transmission/wheels			
Drive type			
Transmission type			
Wheels			
Tyres			
Weights/capacities			
Unladen weight <sup>2</sup> in kg			
Gross vehicle weight in kg			
Permissible roof load limit in kg			
Fuel tank capacity, approx. in l			
Performance/consumption <sup>3</sup>			
Top speed in km/h			
Acceleration 0–100 km/h in s			
Fuel grade			
Fuel consumption <sup>6</sup> in l/100 km	urban	extra-urban	combined
CO <sub>2</sub> emission <sup>6</sup> in g/km	urban	extra-urban	combined
Emission standard			

RS 5 Coupé		
V8 cylinder petrol engine with direct fuel injection		
4163 (4)		
331/8250		
430/4000–6000		
quattro® permanent all-wheel drive		
7-speed S tronic		
Forged aluminium wheels, 9 J x 19		
265/35 R 19		
1790		
2215		
75		
61		
250 <sup>4</sup>		
4.5		
Sulphur-free super plus RON 98 <sup>5</sup>		
14.4	8.3	10.5
336	194	246
EUS		

## Notes

<sup>1</sup> The figure stated was calculated using the specified measuring procedure (current version of Directive 80/1269/EEC).

<sup>2</sup> Unladen vehicle weight includes driver (68 kg), 7 kg of luggage and fuel tank 90% full, calculated in accordance with the current version of EC Directive 92/21/EEC. Optional equipment may increase the car’s unladen weight and drag coefficient, whereupon the possible payload limit and the top speed will be reduced accordingly.

<sup>3</sup> A vehicle’s fuel consumption and CO<sub>2</sub> emissions do not just depend on how efficiently the vehicle uses the fuel, but are also influenced by driving behaviour and other non-technical factors. CO<sub>2</sub> is the greenhouse gas primarily responsible for global warming.

<sup>4</sup> Regulated.

<sup>5</sup> We recommend using sulphur-free SuperPlus unleaded RON 98 in accordance with DIN EN 228. If not available, use sulphur-free regular unleaded RON 95 fuel in accordance with DIN EN 228; power output will be slightly reduced. Unleaded RON 95 fuel with a maximum ethanol content of 10% (E10) can generally be used. Fuel consumption details refer to operation with RON 95 fuel in accordance with 692/2008/EC.

<sup>6</sup> The figures given were calculated using the specified measuring procedures. The figures do not refer to one individual vehicle and do not form part of any offer, but rather should be used purely for purposes of comparison between the different vehicle models.

## Important note

Inspections are due as shown by the service display.

<sup>[1]</sup> \*Optional



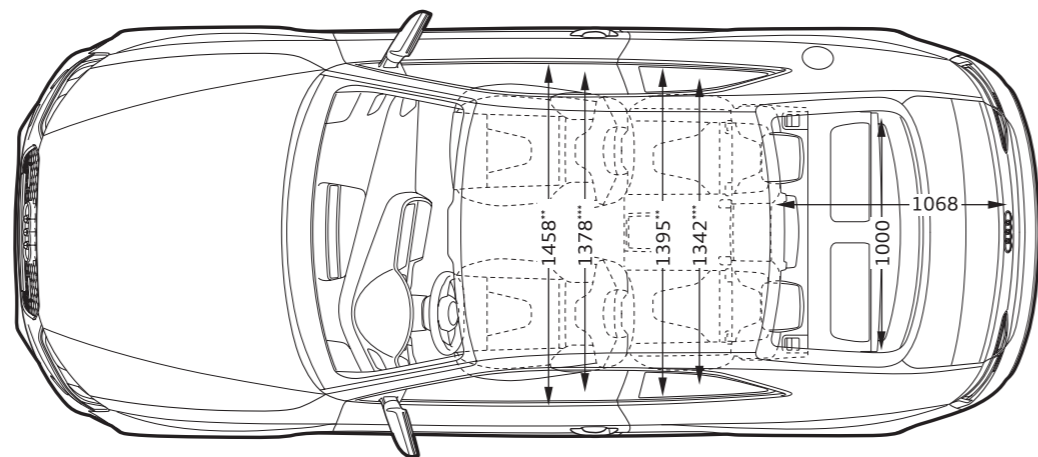
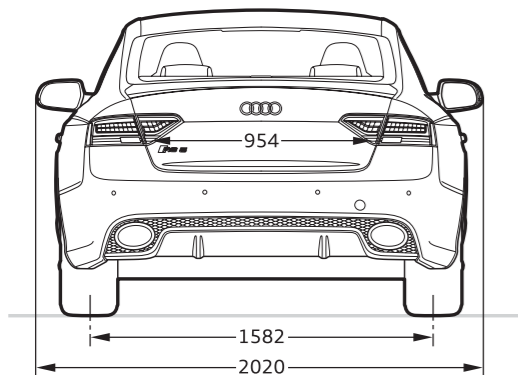
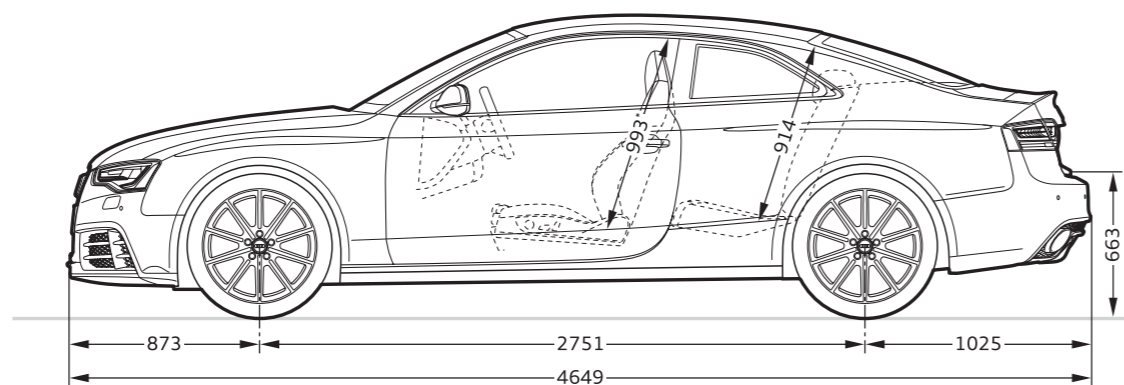
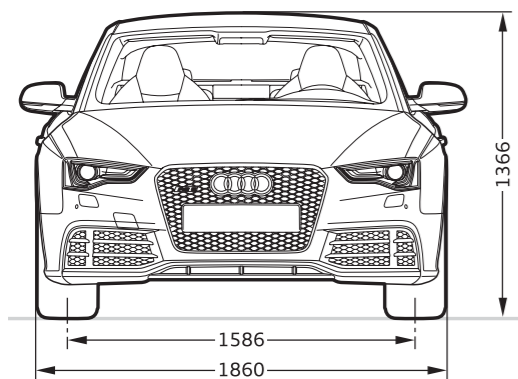

**Dimensions in millimetres.**

Dimensions were measured with vehicle at unladen weight.

Luggage compartment volume 455/829 l (measured by the VDA method, using 200 x 100 x 50 mm blocks; second value with rear seat backrests folded down).

Turning circle approx. 11,6 m.

\*Maximum headroom. \*\*Elbow room width. \*\*\*Shoulder room width.









**quattro GmbH**  
85045 Ingolstadt  
[www.audi.com](http://www.audi.com)  
Valid from April 2012

Printed in Germany  
258/1152.00.18

The models and equipment versions illustrated and described in this brochure and some of the services listed are not available in all countries. Some of the cars illustrated are equipped with optional features for which an extra charge is made. Details concerning the delivery specifications, appearance, performance, dimensions and weights, fuel consumption and running costs of the vehicle were correct to the best of our knowledge at the time of going to press. Deviations from the colours and shapes shown in the illustrations may occur. No liability is accepted for errors and printing errors. The right to introduce modifications is reserved. Not to be reproduced, including in part, without the written approval of AUDI AG

This brochure is printed on paper made from pulp bleached without the use of chlorine.