

NEXA | [www.nexaexperience.com](http://www.nexaexperience.com)

 **MARUTI SUZUKI**



*Ciaz*



# THE NEW CIAZ

There's brilliance in its design. There's an air of elegance about it. It's built with indulgence at its core. And there are innovations that stand out. It takes just one glance, just one drive to realise, this is no ordinary experience. This is a dream come true. This is the New Ciaz. Created and perfected for inspiration. So, think, create and innovate. With the Ciaz, you are ready to seek out the new.





# CREATED TO INSPIRE ELEGANCE

It's fine to look again, and again and once more. To steal another glimpse of this charmer called Ciaz. The striking new grille and slick front bumpers give this stunner a surprisingly smooth look. The LED projector headlamps with DRL and LED fog lamps lend an all white brilliance to its persona. Made with gracefully designed LED tail lamps, Ciaz is what elegance looks like, cruising through the city.





The image shows the interior of a car, viewed from the passenger side. The seats are upholstered in a light beige or cream-colored leather with visible stitching. The dashboard and center console are finished with a dark wood grain, likely birch, and feature chrome accents. The steering wheel is black with a silver logo in the center. The car is parked in a city, with tall buildings visible through the windows. The overall atmosphere is one of luxury and comfort.

## CREATED TO INSPIRE LUXURY

Imagine a lounge. Gorgeous. Indulgent. Comfortable. Expansive. That's the experience. The feeling of Ciaz. The charm begins the moment you step inside and breathe in the most spacious cabin. Followed by your eyes feasting on the birch blonde wood finish with satin chrome accents, your skin embracing the luxurious seating, and your whole being giving in to this thoughtfully designed beauty quietly, calmly.



# CREATED TO INSPIRE PERFORMANCE

## **New K15 Petrol Engine**

Engineered for a great driving experience, this engine is the new and the next in the world of power. And with the Progressive Smart Hybrid Technology, it's ready for the future. The engine's torque and power output gives you an experience that simply enhances your drive. With this new engine, Ciaz ensures your drive is smoother than ever and packed with renewed power. Created to inspire a better tomorrow.



## **DDiS 200 Diesel Engine**

The D13 engine is equipped with Proven Smart Hybrid Technology. It is simply made to give you a powerfully smooth driving experience with its Variable Geometry Turbocharger, which generates optimum power and excellent torque. Now, your drive will stay amazing miles after miles.

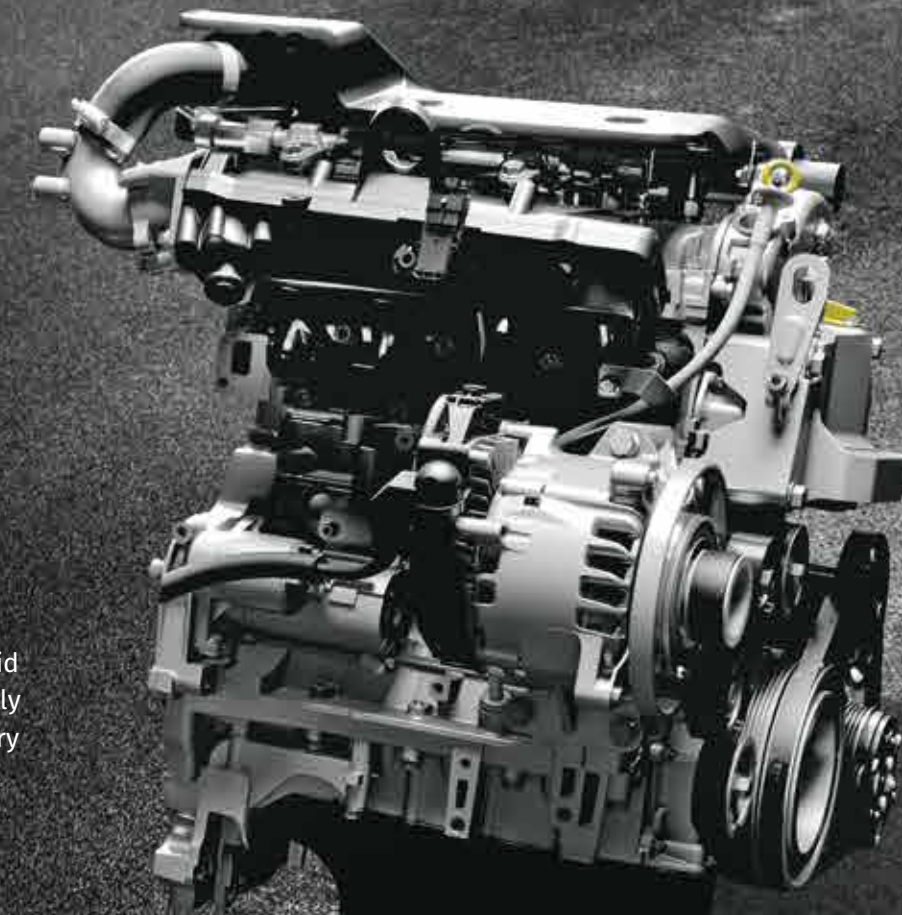





## CREATED TO INSPIRE CHANGE

### PROGRESSIVE NEXT GENERATION SMART HYBRID\*

Every few years a revolution comes along to change the way you see the world. To make it better. To make it smarter. And the Progressive Next Generation Smart Hybrid Technology is just that. With its Lithium-ion and Lead Acid Dual Battery set up, you get an enhanced driving experience. What's more, the Torque Assist Function reduces the stress on the engine and the fuel consumption.

- **IDLE START STOP**  
The engine automatically stops when idle and silently starts when the optimal conditions are met in manual and automatic transmissions. This helps in increasing the fuel efficiency.
- **BRAKE ENERGY REGENERATION**  
Braking charges the special high capacity batteries, which in return assist the engine's idle start stop and the torque assist functions.
- **TORQUE ASSIST FUNCTION**  
The energy stored in the Lithium-ion battery assists during acceleration. This helps the engine in providing optimal acceleration and performance.

\*Only for K15 Engine



# CREATED TO INSPIRE COMFORT

Relax through the busiest of lanes, the dreaded rush hour, the long tiring signals. Unwind and enjoy your drive as the Ciaz with Automatic Transmission moves like a dream, giving you a comfortable drive everywhere.

The Ciaz Automatic Smart Hybrid also comes with enhanced safety features like the Electronic Stability Program (ESP) with Hill Hold Assist. These thoughtfully designed features are sure to make your driving experience safer.



Electronic Stability Program



Hill Hold Assist



## MULTI-INFORMATION DISPLAY

The Ciaz comes with a new 4.2 inch TFT Multi-information Display that makes it convenient for you to keep a track of your car's vital information. This includes fuel consumption, energy flow, trip details, driving range and gear shift indicator (MT).



## CRUISE CONTROL

Your journeys in the Ciaz will now be more comfortable with the Cruise Control Feature System that lets you pick any cruising speed over 40 km/h. So click and drive through the highway with unmatched ease.



# CREATED TO INSPIRE INNOVATION

Call. Connect. Talk. Message. Play. Listen. Touch. Search. Navigate. That's just some of the few things you can do with the SmartPlay Infotainment System. Appointed with Apple CarPlay\*, Android Auto\*\* and MirrorLink#, you can seamlessly connect your smartphones and access unlimited entertainment and uninterrupted connectivity. Step inside the Ciaz and experience a whole different world of innovation.



\*Apple and iPhone are trademarks of Apple Inc., registered in the U.S. and other countries. Apple CarPlay is a trademark of Apple Inc. Apple CarPlay is available in the countries listed in the following link: <http://www.apple.com/ios/feature-availability/#applecarplay-applecarplay>.

Apple CarPlay is compatible with the iPhone models listed in the following link: <http://www.apple.com/ios/carplay>.

#MirrorLink™ is a certification mark of the Car Connectivity Consortium LLC. For the list of MirrorLink compatible Smartphones see: <https://cert.mirrorlink.com/ProductListing/>

\*\*Android Auto™ extends the Android platform into the car in a way that's purpose-built for driving. It is designed to minimise distraction so you can focus on driving with Google™ services like Google Maps™ and Google Search™. Get the Android Auto app on Google Play™. Android Auto is available in the countries listed at the following link: <https://www.android.com/auto/#hit-the-road>. Most phones with Android 5.0+ work with Android Auto: <https://support.google.com/androidauto/#6140477>. Android, Android Auto, Google, Google Play and other marks are trademarks of Google Inc.



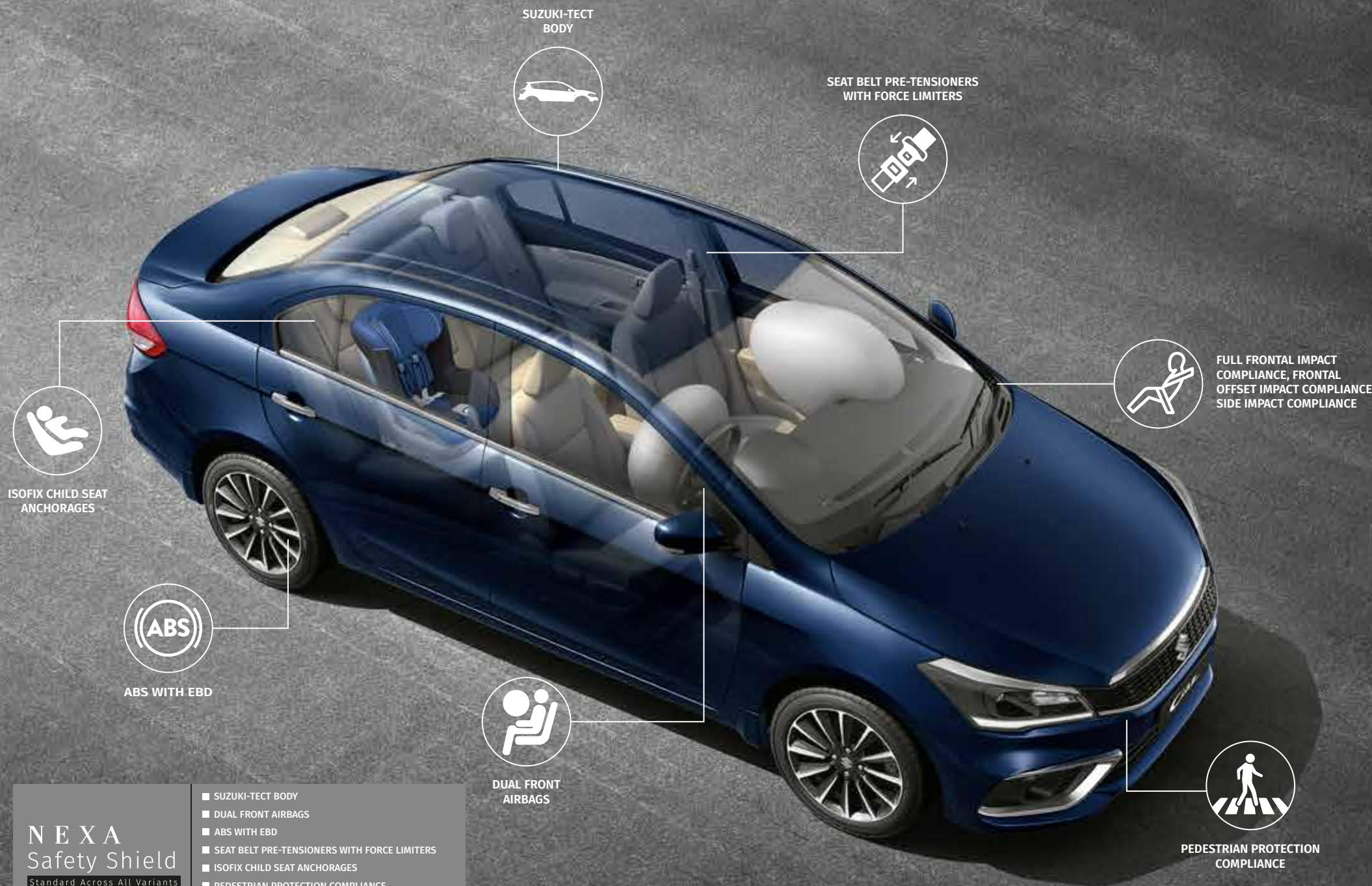

SUZUKI-TECT BODY



SEAT BELT PRE-TENSIONERS WITH FORCE LIMITERS



FULL FRONTAL IMPACT COMPLIANCE, FRONTAL OFFSET IMPACT COMPLIANCE, SIDE IMPACT COMPLIANCE



ISOFIX CHILD SEAT ANCHORAGES



ABS WITH EBD



DUAL FRONT AIRBAGS



PEDESTRIAN PROTECTION COMPLIANCE

# CREATED TO INSPIRE SAFER ROADS

Comfort and luxury are integral to the Ciaz experience, but it's the safety that undoubtedly comes first and foremost. Equipped with the NEXA Safety Shield, a collection of advanced safety features that adheres to the highest safety standards - the Ciaz assures your complete and utmost protection.

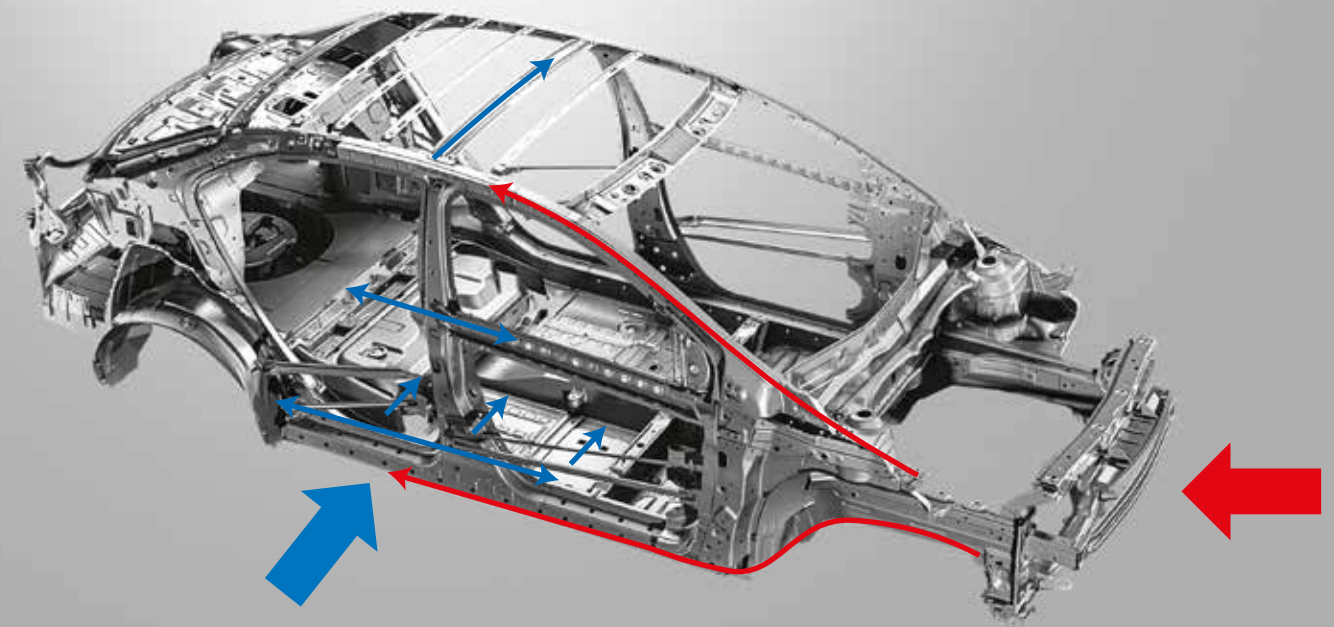

## SUZUKI-TECT BODY

Suzuki's Total Effective Control Technology (TECT) concept results in effective absorption and dispersion of crash energy. The extensive use of high-tensile steel for major parts makes the body light, strong and safe.



## DUAL FRONT AIRBAGS

Front airbags for the driver and passenger mitigate the collision forces inflicted on the head in the event of a frontal impact.

**NEXA**  
Safety Shield

Standard Across All Variants

- SUZUKI-TECT BODY
- DUAL FRONT AIRBAGS
- ABS WITH EBD
- SEAT BELT PRE-TENSIONERS WITH FORCE LIMITERS
- ISOFIX CHILD SEAT ANCHORAGES
- PEDESTRIAN PROTECTION COMPLIANCE
- FULL FRONTAL IMPACT COMPLIANCE, FRONTAL OFFSET IMPACT COMPLIANCE, SIDE IMPACT COMPLIANCE



# CREATE. INSPIRE.

NEXA is on a journey to create new experiences, new lifestyle, new culture and new products that inspire.  
It is a drive of creation. A quest to inspire. A celebration of the creators. An ode to the creators who inspire.





CREATED  
TO INSPIRE  
A VIVID WORLD



METALLIC MAGMA GRAY

PEARL MIDNIGHT BLACK

NEXA BLUE

PEARL SANGRIA RED

PEARL METALLIC DIGNITY BROWN

METALLIC PREMIUM SILVER

PEARL SNOW WHITE



TECHNICAL SPECIFICATIONS		
DIMENSIONS	PETROL SMART HYBRID	DIESEL SMART HYBRID
Length (mm)	4490	
Width (mm)	1730	
Height (mm)	1485	
Wheelbase (mm)	2650	
Boot Space (L)	510*	
Turning Radius (m)	5.4	
Seating Capacity	5	
DRIVE, TRANSMISSION		
Drive System	2WD	
Transmission	5MT/4AT	5MT
ENGINE		
Valve System	DOHC	
Engine Capacity (cc)	1462	1248
Bore x Stroke (mm)	74 x 85	69.6 x 82
Max. Power (kW/RPM)	77/6000	66/4000
Max. Torque (Nm/RPM)	138/4400	200/1750
Fuel Tank Capacity (L)	43	
Fuel Efficiency (km/l)**	21.56(MT) / 20.28(AT)	28.09
Emission Standard	BS IV	
Idle Start Stop	✓	
Gear Shift Indicator	✓(MT)	✓
Brake Energy Regeneration	✓	
Torque Assist	✓	
DRIVE PERFORMANCE		
Front Brakes	Ventilated Disc	
Rear Brakes	Drum	
Front Suspension	McPherson	
Rear Suspension	Torsion Beam	
Tyre Size	185/65 R15 (Steel & Alloy)	195/55 R16 (Alloy)
WEIGHTS		
GVW (kg)	1520(MT)	1590



16" Precision Cut Alloy    15" Silver Alloy    15" Steel Wheels With Full Wheel Caps

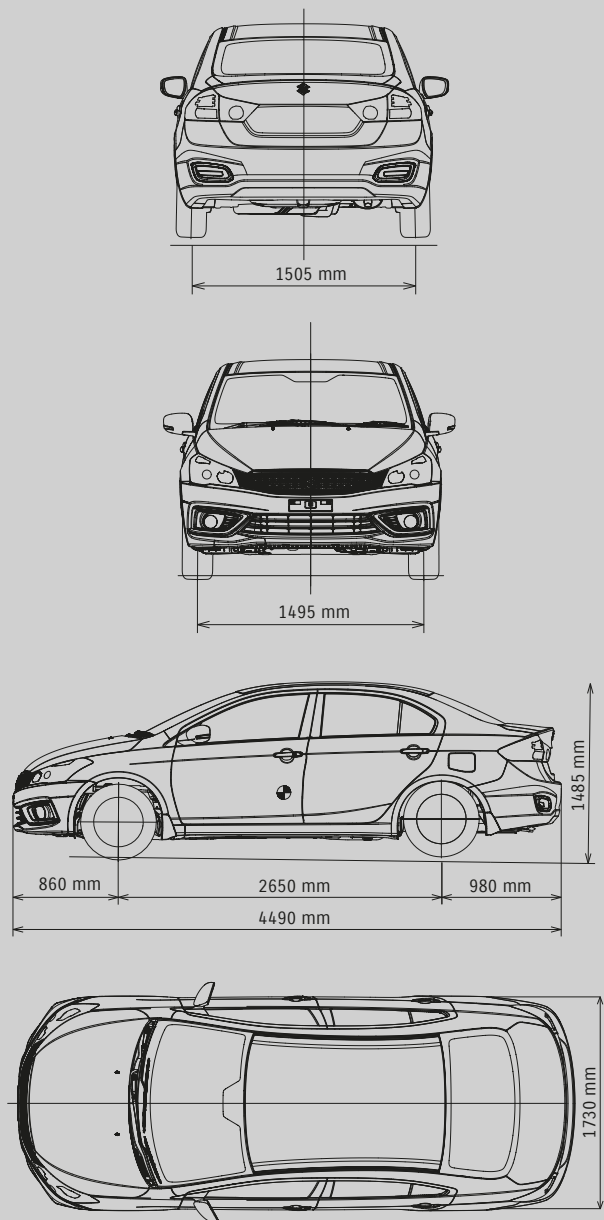

Maruti Suzuki India Limited reserves the right to change, without notice, price, colours, equipment specifications, and models and also to discontinue models and/or replace any part or accessory with any other product. Accessory and feature shown in the pictures may not be a part of standard equipment and will differ according to the variant. Any offers made will be subject to availability of the product. For more details, contact your nearest NEXA Dealership.

If the vehicle's speed exceeds 80 km/h, then the primary level warning will beep twice. And if the speed goes above 120 km/h, the secondary level warning will keep beeping. If the vehicle's speed slows down to 118 km/h, it will beep twice and the buzzer will stop. This buzzer does not indicate any malfunction in the vehicle.

All the safety features are standard and available across all the variants.

FEATURE LIST				
VARIANTS	Sigma	Delta	Zeta	Alpha
EXTERIOR				
Halogen Projector Headlamps	✓	✓	X	X
LED Projector Headlamps	X	X	✓	✓
Integrated LED Daytime Running Lamps (DRL)	X	X	✓	✓
Split Rear Combination Lamps	✓	✓	✓	✓
LED Rear Combination Lamps	X	X	✓	✓
Alloy Wheels <sup>†</sup>	X	185/65 R15	185/65 R15	195/55 R16
Chrome Accents on Front Grille	✓	✓	✓	✓
Trunk Lid Chrome Garnish	X	X	X	✓
Door Beltline Garnish	X	X	X	✓
Glass Antenna	✓	✓	✓	✓
Body Coloured ORVMs with Turn Indicators	✓	✓	✓	✓
Body Coloured Door Handles	✓	✓	Chrome	Chrome
Front Fog Lamp Ornament	Black	Silver		Chrome
Rear Reflector Ornament	X	Silver		Chrome
Wheel Cap	✓	X	X	X
INTERIOR				
Leather Seat Upholstery <sup>‡</sup>	X	X	X	✓
Leather Wrapped Steering Wheel	X	X	X	✓
Chrome Garnish (Steering Wheel, Inside Door Handles, AC Louvers Knob, Parking Brake Lever)	✓	✓	✓	✓
MID - Diesel	✓	✓	✓	✓
MID - Petrol (With Coloured TFT)	✓	✓	✓	✓
ECO Illumination (Petrol)	✓	✓	✓	✓
Wooden Finish on I/P & Door Garnish	✓	✓	✓	✓
Satin Finish on AC Louvers	Front+Centre	Front	Front+Rear	Front+Rear
Rear Seat Adjustable Headrest	X	X	✓	✓
Chrome Finish on Floor Console	X	✓	✓	✓
COMFORT AND CONVENIENCE				
Intelligent Key (Push Start/Stop)	X	X	✓	✓
Cruise Control	X	✓	✓	✓
Electrically Adjustable ORVMs	✓	✓	✓	✓
Electrically Foldable ORVMs	X	X	✓	✓
Keyless Entry	✓	✓	✓	✓
Power Windows (Dr. side Auto Up/Down with Anti-pinch)	✓	✓	✓	✓
Auto AC	Manual	✓	✓	✓
Rear AC Vents	✓	✓	✓	✓
Pollen Filter	✓	✓	✓	✓
Front Centre Armrest (With Utility Box)	✓	✓	✓	✓
Rear Centre Armrest (With Cup Holders)	✓	✓	✓	✓
Height Adj. Driver Seat	X	✓	✓	✓

FEATURE LIST				
VARIANTS	Sigma	Delta	Zeta	Alpha
COMFORT AND CONVENIENCE				
Rear Sunshade	X	X	✓	✓
Footwell Lamps (Driver + Passenger Side)	X	X	✓	✓
Rear Reading Lamps	X	X	✓	✓
Sunglass Holder	X	X	✓	✓
Accessory Socket (Front and Rear)	✓	✓	✓	✓
Tilt Steering	✓	✓	✓	✓
AUDIO/INFOTAINMENT				
17.8 cm Touchscreen SmartPlay Infotainment System	X	X	X	✓
Bluetooth Connectivity	✓	✓	✓	✓
Inbuilt Navigation System	X	X	X	✓
Mirror Link support for SmartPhone Connectivity	X	X	X	✓
Voice Command System	X	X	X	✓
Audio with CD Player	✓	✓	✓	X
Speakers + Tweeters (4 + 2 Nos.)	✓	✓	✓	✓
USB Connectivity	✓	✓	✓	✓
Steering Mounted Audio Controls	✓	✓	✓	✓
Steering Mounted Calling Controls	✓	✓	✓	✓
SAFETY				
Automatic Headlamps (With Auto Levelling)	X	X	✓	✓
Front Fog Lamps	X	✓	LED	LED
Rear Defogger	✓	✓	✓	✓
Auto Day/Night IRVM	Manual	Manual	✓ (With Camera Display)	✓
Reverse Parking Sensor	✓	✓	✓	✓
Reverse Parking Camera	X	X	✓	✓
Anti-theft Security System	✓	✓	✓	✓
Electronic Stability Program with Hill-hold	X	AT only	AT only	AT only
Seat Belt Reminder (Driver + Passenger)	✓	✓	✓	✓
Speed Alert system	✓	✓	✓	✓

## NEXA

### Safety Shield

Standard Across All Variants

- SUZUKI-TECT BODY
- DUAL FRONT AIRBAGS
- ABS WITH EBD
- SEAT BELT PRE-TENSIONERS WITH FORCE LIMITERS
- ISOFIX CHILD SEAT ANCHORAGES
- PEDESTRIAN PROTECTION COMPLIANCE
- FULL FRONTAL IMPACT COMPLIANT, FRONTAL OFFSET IMPACT COMPLIANT, SIDE IMPACT COMPLIANT

LEGEND: (✓) Available; (X) Not Available

<sup>†</sup>Spare wheel material is steel & spare tyre size is 185/65 R15.

<sup>‡</sup>Some parts of the Leather Appointed Seat Upholstery will contain man-made material.

<sup>§</sup>VDA Method.

<sup>\*\*</sup>As Certified by Test Agency Under Rule 115 of CMVR 1989.

Features shown may vary from variant to variant. Car's headlights have been enhanced as per the ambience. Car colour may vary due to printing on paper. Images are used for illustration purposes. Appearance of black glass is due to lighting effect. Automatic Transmission is available in Delta, Zeta and Alpha variants.